

API 610 10th ed. Process Pump(VS6)

API 610 10th ed. Process Pump(VS6)

TVCP

Series

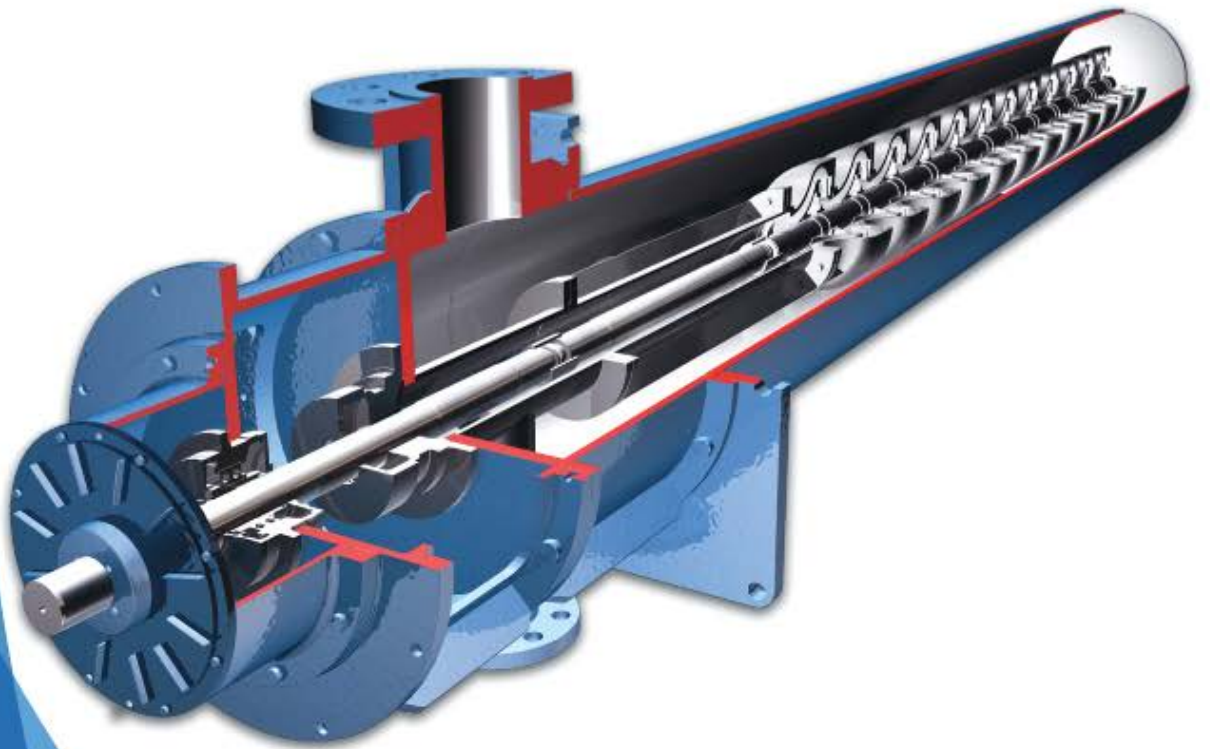

TRUFLO™
QUALITY • VALUE • SERVICE

TRUFLO VS6 SERIES

API 610 10th Edition Process Pump

Capacity: Max 5,000 m ³ /h (22,000GPM)	Material: DCI, WCB, CF8, CD4M, CN7M
Delivery head: Max 1,060m (3,500ft)	HASTELLOY B&C,
Pressure: Max 75kg/cm ² (11,000psi)	- Fabricated discharge head
Temperature: 260°C (500°F)	- Flanged bowl construction
Horsepower: 1860 kW (2,450 Hp)	- Optional suction in can for flexibility
	- Alloy construction for corrosive /abrasive services.

The TRUFLO VS6 pumps are vertically suspended, double casing (canned), bowl diffuser pumps. These pumps are specifically designed for condensate extraction service in power plants to meet low NPSHa criterion.

Simple construction of TRUFLO VS6 pump offers easy maintenance and installation.

APPLICATION

Pipeline Booster
Ammonia Transfer
Boiler Feed
Cryogenics

Product Unloading, Refinery Blending
Injection-Secondary Recovery
Condensate

API



Fabricated Discharge Head



Flanged Column

Can

Bowl Assembly

Suction Bell

- Allows smooth entry of liquid into impeller eye, minimizes vortex formation.

Suction Bell Bearing

- Provided for shaft stability.

Sand Collar

- Prevents solids from entering suction bearing.

Impeller

- Semi-open or enclosed for appropriate service.

Taper Lock

- Alloy steel for fastening impellers on 17" and smaller sizes.

Keyed

- Impeller fastened onto the shaft by keyed split ring.

Pump Shaft

- Heavy duty 416SS standard, available in 316SS, 17-4 PH, Monel and other alloys for strength and corrosion resistance.

Diffuser Bowl

- Available in variety of cast materials.
- Glass lined cast iron standard through 18" sizes.

Stages

- Flanged and bolted for easy maintenance.

Sleeve Type Bearing

- Provided at each stage to ensure stable operation away from critical speed.

Flanged Bowls

- Registered fits assure positive alignment, easy maintenance.

610 10th ed. **Process Pump (VS6)**

Pump Selection Guide

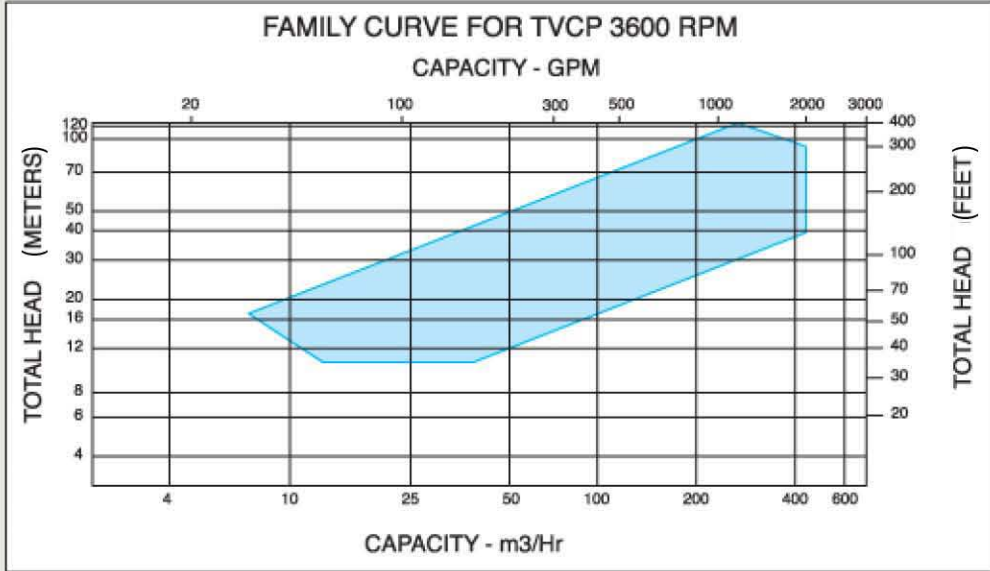

* Head is per stage

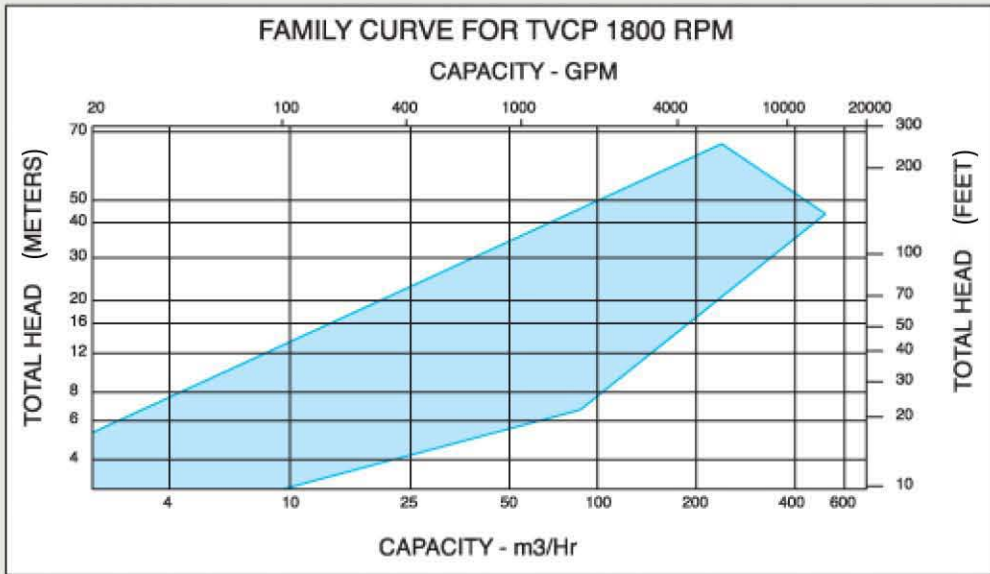

* Head is per stage

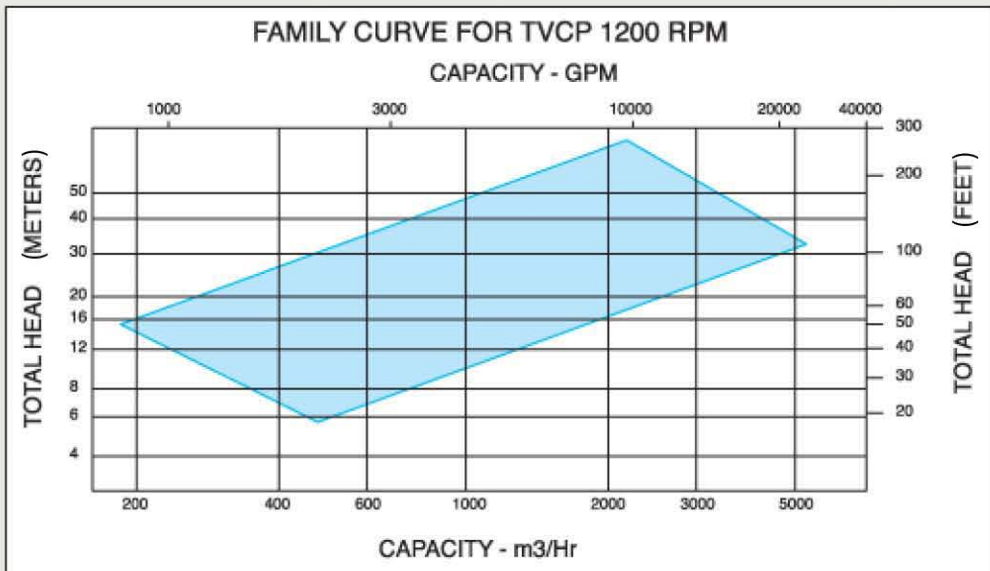

* Head is per stage

TVCP Series

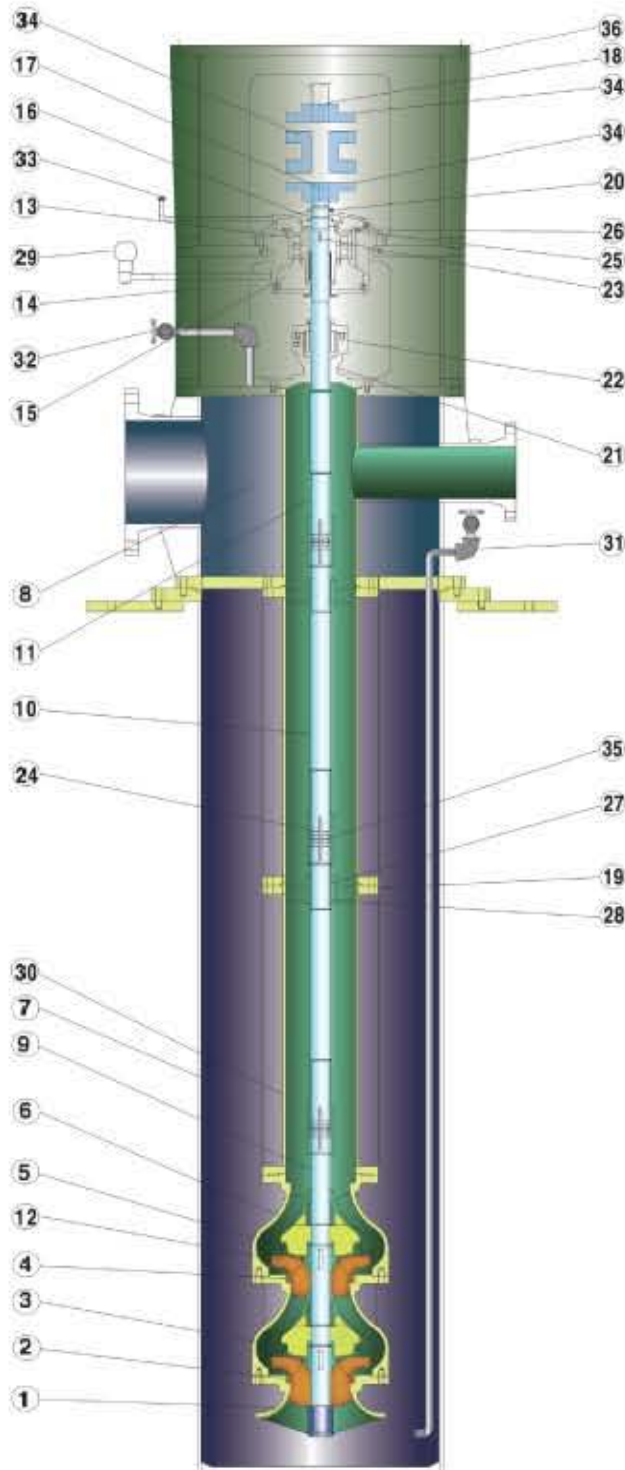

NO.	PART NAME
1	SUCTION BELL
2	CASE WEARING RING(FRONT)
3	CASE WEARING RING(BACK)
4	IMPELLER WEARING RING(FRONT)
5	IMPELLER WEARING RING(BACK)
6	BOWL
7	CAN
8	DISCHARGE HEAD
9	LOWER SHAFT
10	INTER SHAFT
11	UPPER SHAFT
12	IMPELLER
13	THRUST BEARING
14	LOWER ADAPTOR
15	BEARING HOUSING
16	BEARING COVER
17	COUPLING KEY(PUMP SIDE)
18	COUPLING KEY(MOTOR SIDE)
19	BEARING RETAINER
20	LABYRINTH OIL SEAL
21	STUFFING BOX
22	MECHANICAL SEAL ASS'Y
23	BEARING HOLDER KEY
24	INTER COUPLING KEY
25	THRUST BEARING HOLDER
26	THRUST BEARING HOLDER+NUT
27	SLEEVE(RETAINER)
28	SLEEVE BEARING
29	CONSTANT LEVEL OILER
30	COLUMN PIPE
31	CASING DRAIN LINE
32	VENT
33	OIL CAP
34	COUPLING ASS'Y
35	INTER COUPLING UNIT
36	UPPER ADAPTOR