

MOUVEX
MODEL :

PARTS LIST
AS125

P.L. : 1101-P02

(See Instructions 1101-P00 for Installation, Operation and Maintenance)

Section Effective	1101 June 2011
Replaces	October 2010

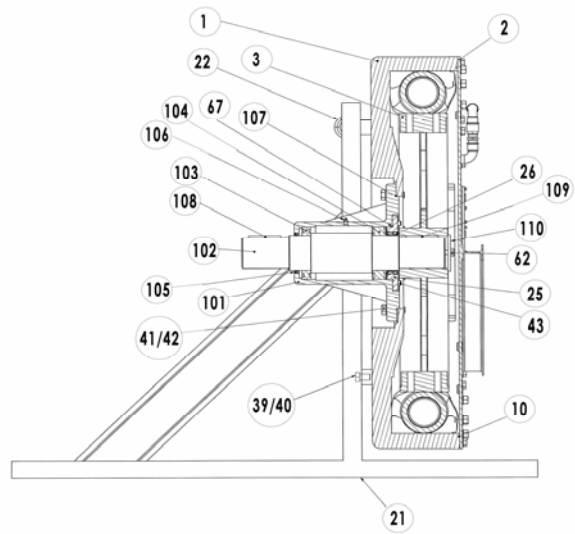
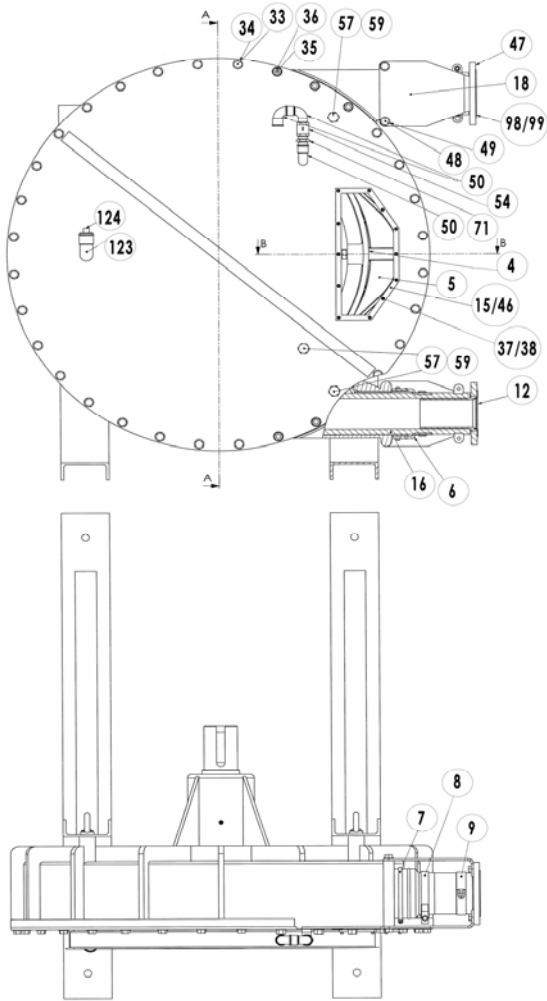

COUPE A-A

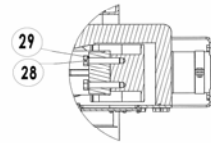

COUPE B-B

Reference			Description	Variants	Quantity		Article code	Wear parts
Ass.	Part	Available			Order	In Pump	AS125	
	3	▲	Wheel		1		217297	
	10	▲	Cover seal		1		220205	•
	12	▲	Insert	Stainless steel	1	2	217334	
1100		▲	Lubricant - Glycerin	30 liters	1		314224.00	•
	15	▲	Window		1		220212	
	16	▲	Hose	NR	1		218751	•
	16	▲	Hose	NBR	1		218752	•
	16	▲	Hose	EPDM	1		218753	•
	18	▲	Bracket		1	4	219104	
	46	▲	Window seal		1		217400	
114	4	◆	Set of shims Removable shim		1	(14)	312364.00	
116		◆	Wheel fixation kit Screw Washer		1	(1) (1)	312810.00	
117		◆	Bearing box Tightness cover Shaft seal Screw Seal Bearing box Pump Shaft Bearing Bearing Seal Grease nipple Seal Key Key		1	(1) (2) (8) (1) (1) (1) (1) (1) (1) (1) (1) (1) (1) (1)	312819.00	

Reference			Description	Variants	Quantity		Article code	Wear parts
Ass.	Part	Available			Order	In Pump	AS125	
118	6+7	◆	Boot + Hose clamp		1		312816.00	
	8		Nipple + Hose clamp			(2)		
	9		Hose clamp			(2)		
			Hose clamp			(2)		
119	4a	◆	Set of shoes	Iron	1		312821.00	
	4b		Fixed shim			(8)		
	5		Fixed shim			(4)		
			Shoe			(2)		
130	50	◆	Puncture detection kit		1		311839.00	
	54		Elbow			(1)		
	71		Valve			(1)		
	72		Fitting			(2)		
	73		Tee			(1)		
	76		Elbow			(1)		
	77		Fitting			(1)		
	78		Connector			(1)		
			Capacitive detector			(1)		
130	50	◆	Puncture detection kit ATEX		1		313746.00	
	54		Elbow			(1)		
	71		Valve			(1)		
	72		Fitting			(2)		
	73		Tee			(1)		
	76		Elbow			(1)		
	77		Fitting			(1)		
	78		Connector			(1)		
	84		Capacitive detector			(1)		
			Amplifier			(1)		

(◆) To order the required spare parts, indicate the appropriate CUM numbers.

Keep this parts lists with Installation, Operation and Maintenance Instructions.

CVT : FEP encapsulated FKM



Z.I. la Plaine des Isles - 2 rue des Caillottes F-89000 AUXERRE - FRANCE

Tel : +33 (0)3 86 49 86 30 • Fax : +33 (0)3 86 49 87 17

contact@mouvex.com • www.mouvex.com