

MOUVEX
MODEL :

PARTS LIST
AS100

P.L. : 1101-N02

(See Instructions 1101-N00 for Installation, Operation and Maintenance)

Section	1101
Effective	June 2011
Replaces	October 2010

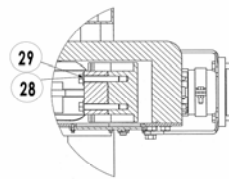
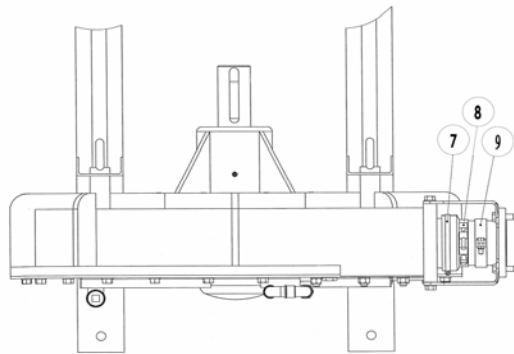
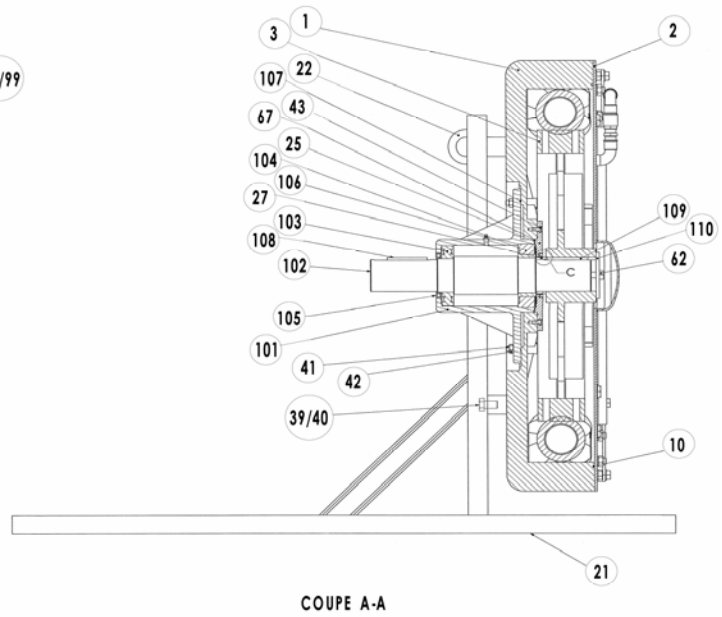
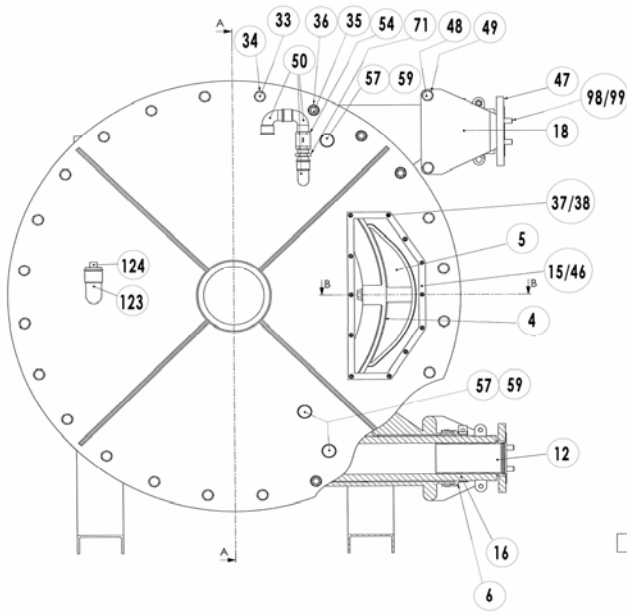

B-B

Reference			Description	Variants	Quantity		Article code	Wear parts
Ass.	Part	Available			Order	In Pump	AS100	
	3	▲	Wheel		1		217295	
	10	▲	Cover seal		1		220204	•
	12	▲	Insert	Stainless steel	1	2	217331	•
	1100	▲	Lubricant - Glycerin	10 liters	1		314223.00	•
	1100	▲	Lubricant - Glycerin	30 liters	1		314224.00	•
	15	▲	Window		1		220212	
	16	▲	Hose	NR	1		218748	•
	16	▲	Hose	NBR	1		218749	•
	16	▲	Hose	EPDM	1		218750	•
	18	▲	Bracket		1	4	219103	
	46	▲	Window seal		1		217400	
114	4	◆	Set of shims Removable shim		1	(14)	312363.00	

Reference			Description	Variants	Quantity		Article code	Wear parts
Ass.	Part	Available			Order	In Pump	AS100	
116		◆	Wheel fixation kit		1		312805.00	
	25		Tightness cover			(1)		
	26		Shaft seal			(1)		
	27		Seal ring			(1)		
	43		Screw			(10)		
	62		Screw			(1)		
	67		Seal			(1)		
	110		Washer			(1)		
117		◆	Bearing box		1		312807.00	
	101		Bearing box			(1)		
	102		Pump Shaft			(1)		
	103		Bearing			(1)		
	104		Bearing			(1)		
	105		Seal			(1)		
	106		Grease nipple			(1)		
	107		Seal			(1)		
	108		Key			(1)		
	109		Key			(1)		
118		◆	Boot + Hose clamp		1		312806.00	
	6+7		Nipple + Hose clamp			(2)		
	8		Hose clamp			(2)		
	9		Hose clamp			(2)		
119		◆	Set of shoes	Iron	1		312809.00	
	4a		Fixed shim			(6)		
	4b		Fixed shim			(4)		
	5		Shoe			(2)		
125		◆	Shaft seal + bushing		1		313047.00	
	26		Shaft seal			(1)		
	27		Seal ring			(1)		
130		◆	Puncture detection kit		1		311839.00	
	50		Elbow			(1)		
	54		Valve			(1)		
	71		Fitting			(2)		
	72		Tee			(1)		
	73		Elbow			(1)		
	76		Fitting			(1)		
	77		Connector			(1)		
	78		Capacitive detector			(1)		
130		◆	Puncture detection kit ATEX		1		313746.00	
	50		Elbow			(1)		
	54		Valve			(1)		
	71		Fitting			(2)		
	72		Tee			(1)		
	73		Elbow			(1)		
	76		Fitting			(1)		
	77		Connector			(1)		
	78		Capacitive detector			(1)		
84		Amplifier			(1)			

(◆) To order the required spare parts, indicate the appropriate CUM numbers.

Keep this parts lists with Installation, Operation and Maintenance Instructions.

CVT : FEP encapsulated FKM



Z.I. la Plaine des Isles - 2 rue des Caillottes F-89000 AUXERRE - FRANCE

Tel : +33 (0)3 86 49 86 30 • Fax : +33 (0)3 86 49 87 17

contact@mouvex.com • www.mouvex.com