

(See Instructions 1101-N00 for Installation, Operation and Maintenance)

Section	1101
Effective	June 2011
Replaces	October 2010

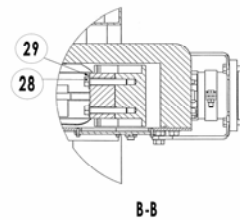
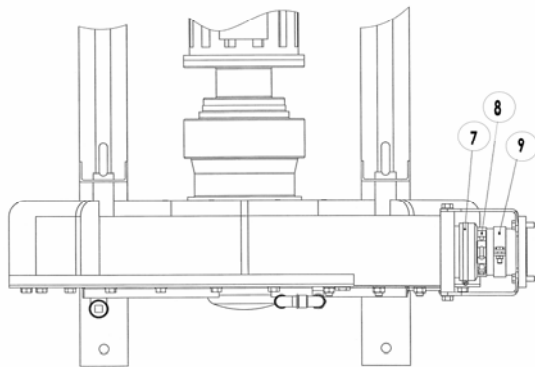
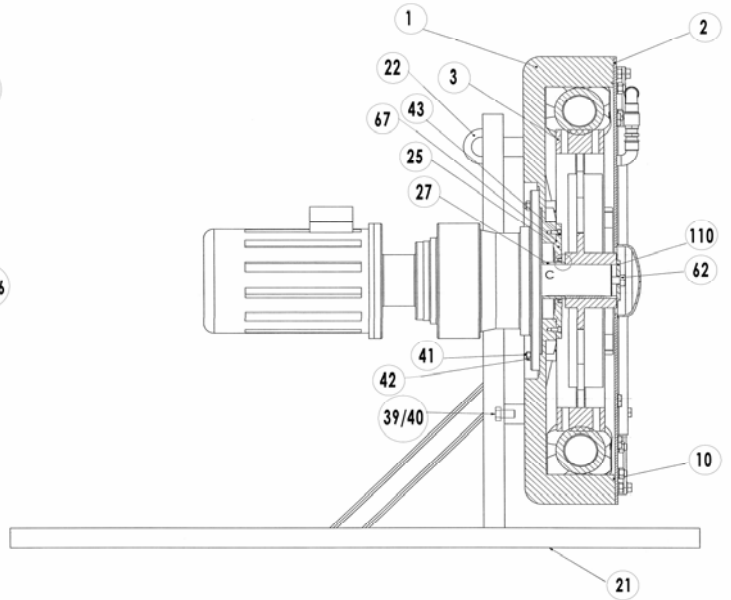
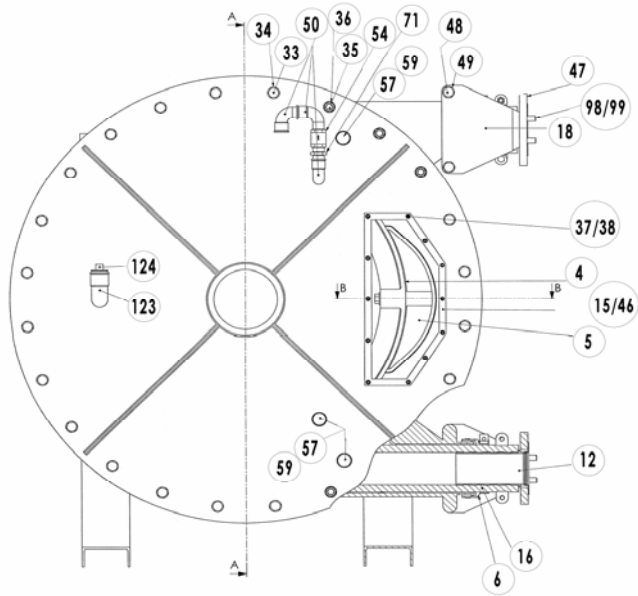

Reference			Description	Variants	Quantity		Article code	Wear parts
Ass.	Part	Available			Order	In Pump	A100	
	3	▲	Wheel		1		217295	
	10	▲	Cover seal		1		220204	
	12	▲	Insert	Stainless steel	1	2	217331	•
	1100	▲	Lubricant - Glycerin	10 liters	1		314223.00	•
	1100	▲	Lubricant - Glycerin	30 liters	1		314224.00	•
	15	▲	Window		1		220212	
	16	▲	Hose	NR	1		218748	•
	16	▲	Hose	NBR	1		218749	•
	16	▲	Hose	EPDM	1		218750	•
	18	▲	Bracket		1	4	219103	
	46	▲	Window seal		1		217400	
<b>114</b>		◆	<b>Set of shims</b>		<b>1</b>		<b>312363.00</b>	
	4		Removable shim			(14)		

Reference			Description	Variants	Quantity		Article code	Wear parts
Ass.	Part	Available			Order	In Pump	A100	
116		◆	<b>Wheel fixation kit</b>		1		312804.00	
		25	Tightness cover			(1)		
		26	Shaft seal			(1)		
		27	Seal ring			(1)		
		27a	Spacer			(1)		
		43	Screw			(10)		
		62	Screw			(1)		
		67	Seal			(1)		
		110	Washer			(1)		
118		◆	<b>Boot + Hose clamp</b>		1		312806.00	
		6+7	Nipple + Hose clamp			(2)		
		8	Hose clamp			(2)		
		9	Hose clamp			(2)		
119		◆	<b>Set of shoes</b>		1		312809.00	
		4a	Fixed shim			(6)		
		4b	Fixed shim			(4)		
	5	Shoe			(2)			
125		◆	<b>Shaft seal + bushing</b>		1		313046.00	
		26	Shaft seal			(1)		
		27	Seal ring			(1)		
130		◆	<b>Puncture detection kit</b>		1		311839.00	
		50	Elbow			(1)		
		54	Valve			(1)		
		71	Fitting			(2)		
		72	Tee			(1)		
		73	Elbow			(1)		
		76	Fitting			(1)		
		77	Connector			(1)		
		78	Capacitive detector			(1)		
130		◆	<b>Puncture detection kit ATEX</b>		1		313746.00	
		50	Elbow			(1)		
		54	Valve			(1)		
		71	Fitting			(2)		
		72	Tee			(1)		
		73	Elbow			(1)		
		76	Fitting			(1)		
		77	Connector			(1)		
		78	Capacitive detector			(1)		
		84	Amplifier			(1)		

(◆) To order the required spare parts, indicate the appropriate CUM numbers.

Keep this parts lists with Installation, Operation and Maintenance Instructions.

CVT : FEP encapsulated FKM



Z.I. la Plaine des Isles - 2 rue des Caillottes F-89000 AUXERRE - FRANCE

Tel : +33 (0)3 86 49 86 30 • Fax : +33 (0)3 86 49 87 17

contact@mouvex.com • www.mouvex.com