

(See Instructions 1101-J00 for Installation, Operation and Maintenance)

Section
Effective
Replaces

1101
June 2011
July 2010

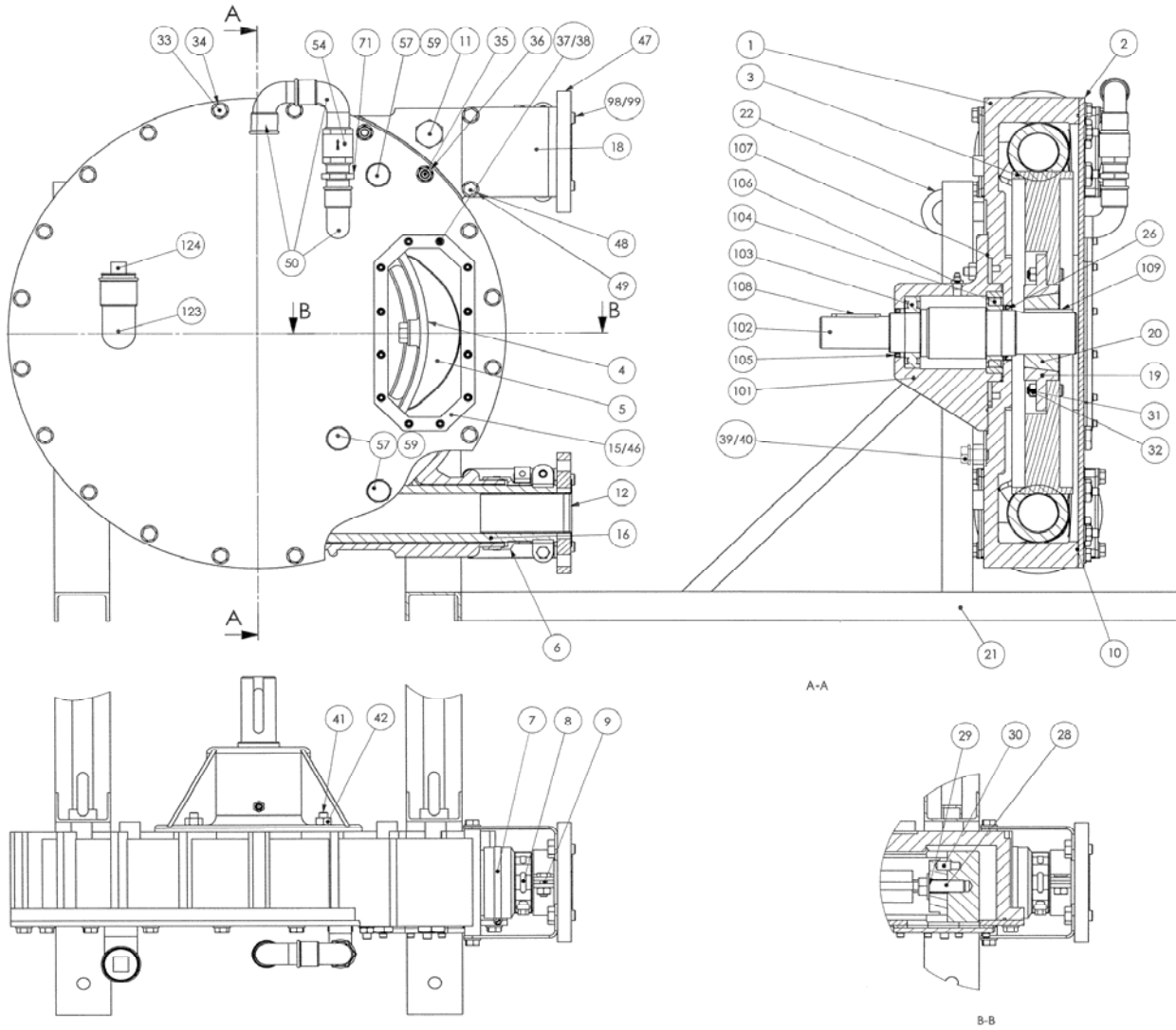

Reference			Description	Variants	Quantity		Article code	Wear parts
Ass.	Part	Available			Order	In Pump	AS65	
	3	▲	Wheel		1		217291	
	10	▲	Cover seal		1		220117	•
	12	▲	Insert	Stainless steel	1	2	217319	
	12	▲	Insert	PPH	1	2	217320	
	12	▲	Insert	PVDF	1	2	217321	
	1100	▲	Lubricant - Glycerin	10 liters	1		314223.00	•
	15	▲	Window		1		220119	
	16	▲	Hose	NR	1		218736	•
	16	▲	Hose	NBR	1		218737	•
	16	▲	Hose	EPDM	1		218738	•
	18	▲	Bracket		1	4	219099	
	20	▲	Hub		1		217156	
	26	▲	Seal		1		220105	
	46	▲	Window seal		1		217397	
114		◆	Set of shims		1		312360.00	
	4		Removable shim			(12)		

Reference			Description	Variants	Quantity		Article code	Wear parts
Ass.	Part	Available			Order	In Pump	AS65	
116	19 31 32	◆	Wheel fixation kit Plate to be screwed Screw Nut		1	(1) (6) (6)	313043.00	
117	101 102 103 104 105 106 107 108 109	◆	Bearing box Bearing box Pump Shaft Bearing Bearing Lip seal Grease nipple Seal Key Key		1	(1) (1) (1) (1) (1) (1) (1) (1) (1)	312734.00	
118	6 7 8 9	◆	Boot + Hose clamp Nipple Hose clamp Hose clamp Hose clamp		1	(2) (2) (2) (2)	312735.00	
119 119	4a 4b 5 30	◆ ◆	Aluminum shoes + shims Iron shoes + shims Fixed shim Fixed shim Shoe Pin		1 1	(4) (4) (2) (2)	312736.00 312737.00	
	26 103 104 105	◆	Box seals/bearings kit Shaft seal Bearing Bearing Seal		1	(1) (1) (1) (1)	313967.00	
130	50 54 71 72 73 76 77 78	◆	Puncture detection kit Elbow Valve Fitting Tee Elbow Fitting Connector Capacitive detector		1	(1) (1) (2) (1) (1) (1) (1) (1)	311839.00	
130	50 54 71 72 73 76 77 78 84	◆	Puncture detection kit ATEX Elbow Valve Fitting Tee Elbow Fitting Connector Capacitive detector Amplifier		1	(1) (1) (2) (1) (1) (1) (1) (1) (1)	313746.00	

(◆) To order the required spare parts, indicate the appropriate CUM numbers.

Keep this parts lists with Installation, Operation and Maintenance Instructions.

CVT : FEP encapsulated FKM



Z.I. la Plaine des Isles - 2 rue des Caillottes F-89000 AUXERRE - FRANCE

Tel : +33 (0)3 86 49 86 30 • Fax : +33 (0)3 86 49 87 17

contact@mouvex.com • www.mouvex.com