

(See Instructions 1101-J00 for Installation, Operation and Maintenance)

Section Effective Replaces 1101 September 2011 June 2010

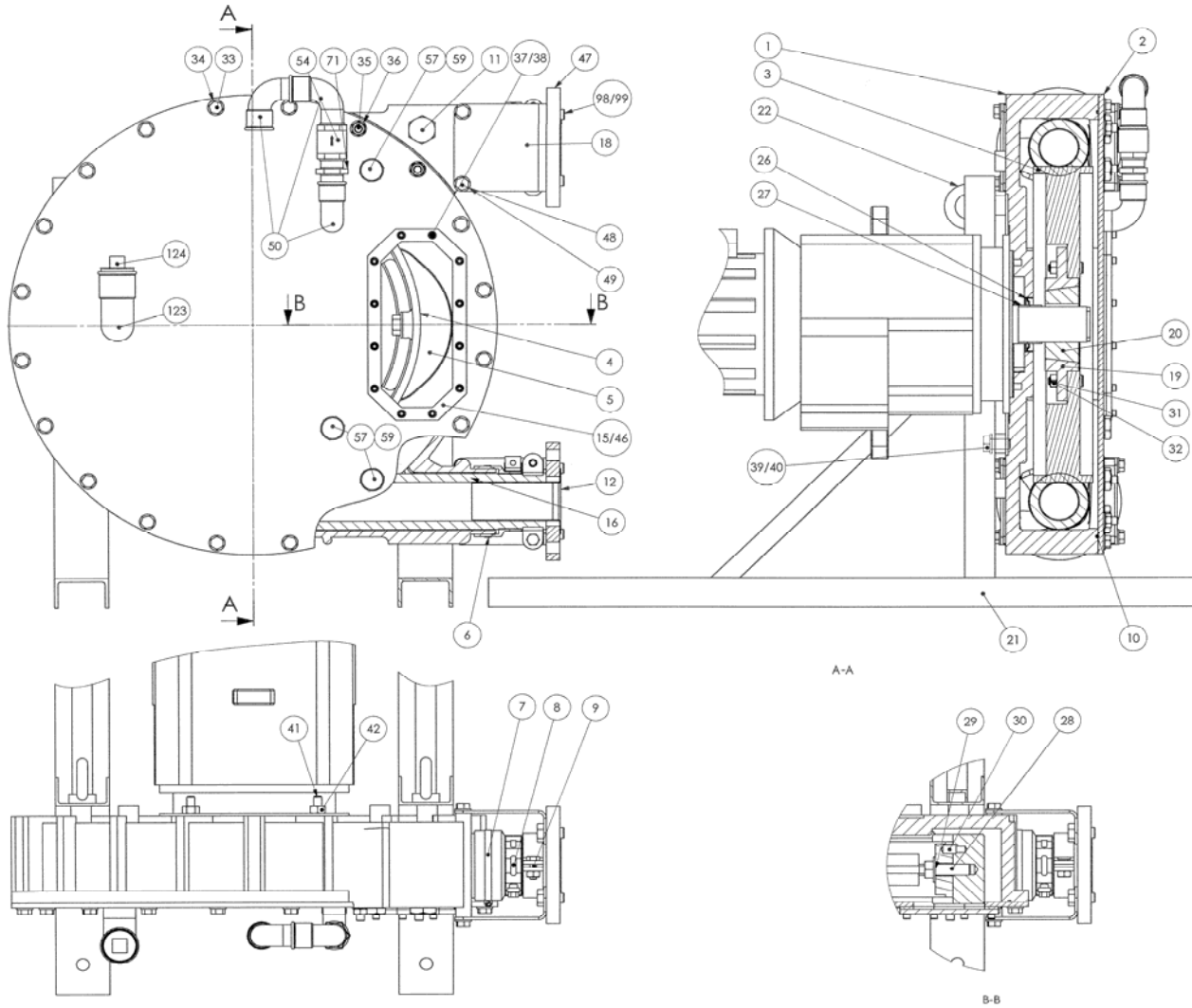

Reference			Description	Variants	Quantity		Article code	Wear parts
Ass.	Part	Available			Order	In Pump	A65	
	3	▲	Wheel		1		217291	
	10	▲	Cover seal		1		220117	•
	12	▲	Insert	Stainless steel	1	2	217319	
	12	▲	Insert	PPH	1	2	217320	
	12	▲	Insert	PVDF	1	2	217321	
	1100	▲	Lubricant - Glycerin	10 liters	1		314223.00	•
	15	▲	Window		1		220119	
	16	▲	Hose	NR	1		218736	•
	16	▲	Hose	NBR	1		218737	•
	16	▲	Hose	EPDM	1		218738	•
	18	▲	Bracket		1	4	219099	
	20	▲	Bushing	Shaft diameter 55	1		217154	
	20	▲	Bushing	Shaft diameter 60	1		217155	
	46	▲	Window seal		1		217397	
114	4	◆	Set of shims Removable shim		1	(12)	312360.00	
116	19 31 32	◆	Wheel fixation kit Plate to be screwed Screw Nut		1	(1) (6) (6)	313040.00	

Reference			Description	Variants	Quantity		Article code	Wear parts
Ass.	Part	Available			Order	In Pump	A65	
118		◆	Boot + Hose clamp		1		312735.00	
	6		Nipple			(2)		
	7		Hose clamp			(2)		
	8		Hose clamp			(2)		
	9		Hose clamp			(2)		
119		◆	Aluminum shoes + shims		1		312736.00	
119		◆	Iron shoes + shims		1		312737.00	
	4a		Fixed shim			(4)		
	4b		Fixed shim			(4)		
	5		Shoe			(2)		
	30		Pin			(2)		
125		◆	Shaft seal + bushing	Shaft diameter 55	1		313041.01	
125		◆	Shaft seal + bushing	Shaft diameter 60	1		313042.00	
	26		Shaft seal			(1)		
	27		Seal ring			(1)		
	27B		Seal ring (313042.00 only)			(1)		
130		◆	Puncture detection kit		1		311839.00	
	50		Elbow			(1)		
	54		Valve			(1)		
	71		Fitting			(2)		
	72		Tee			(1)		
	73		Elbow			(1)		
	76		Fitting			(1)		
	77		Connector			(1)		
	78		Capacitive detector			(1)		
130		◆	Puncture detection kit ATEX		1		313746.00	
	50		Elbow			(1)		
	54		Valve			(1)		
	71		Fitting			(2)		
	72		Tee			(1)		
	73		Elbow			(1)		
	76		Fitting			(1)		
	77		Connector			(1)		
	78		Capacitive detector			(1)		
	84		Amplifier			(1)		

(◆) To order the required spare parts, indicate the appropriate CUM numbers.

Keep this parts lists with Installation, Operation and Maintenance Instructions.

CVT : FEP encapsulated FKM



Z.I. la Plaine des Isles - 2 rue des Caillottes F-89000 AUXERRE - FRANCE

Tel : +33 (0)3 86 49 86 30 • Fax : +33 (0)3 86 49 87 17

contact@mouvex.com • www.mouvex.com