

Intercambiabilità componenti-Interchangeability of parts

TIPO	Corpo supporto			Albero pompa					Cuscinetti				Tenuta sull'albero		
	1	2	3	I	II	III	IV	V	6207 Z 6306 Z	6207 Z 3306	6309 Z 3309	6311 Z 3311	Ø 32	Ø 40	Ø 50
RN,RN4 32-125	•			•					•				•		
RN,RN4 32-160	•				•				•				•		
RN,RN4 32-200	•				•				•				•		
RN,RN4 40-125	•				•				•				•		
RN,RN4 40-160	•				•				•				•		
RN,RN4 40-200C	•				•				•				•		
RN,RN4 40-200A-AR-B	•					•				•			•		
RN,RN4 40-250	•					•				•			•		
RN,RN4 50-125	•				•				•				•		
RN,RN4 50-160	•					•				•			•		
RN,RN4 50-200	•					•				•			•		
RN,RN4 50-250	•					•				•			•		
RN,RN4 65-125E	•				•				•				•		
RN,RN4 65-125A-C	•					•				•			•		
RN,RN4 65-160	•					•				•			•		
RN,RN4 65-200	•					•				•			•		
RN,RN4 65-250		•						•			•			•	
RN4 65-315		•						•			•			•	
RN,RN4 80-160	•					•				•			•		
RN,RN4 80-200		•						•			•			•	
RN,RN4 80-250		•						•			•			•	
RN4 80-315		•						•			•			•	
RN4 80-400			•									•			•
RN,RN4 100-200		•						•			•			•	
RN,RN4 100-250		•						•			•			•	
RN4 100-315		•						•			•			•	
RN4 100-400			•									•			•
RN4 125-250		•						•			•			•	
RN4 125-315			•									•			•
RN4 125-400			•									•			•
RN4 150-315			•									•			•
RN4 150-400			•									•			•

Velocità di rotazione massima ammessa- Maximum permissible rotation speed

3600 1/min			3000 1/min			1800 1/min		
32-125	32-160	32-200						
40-125	40-160	40-200			40-250			
50-125	50-160	50-200			50-250			
65-125	65-160			65-200	65-250		65-315	
	80-200		80-160		80-250		80-315	80-400
	100-200				100-250		100-315	100-400
						125-250	125-315	125-400
							150-315	150-400

I dati indicati non sono impegnativi e possono cambiare con le condizioni di lavoro
Technical data are indicative and they can change according to pump work

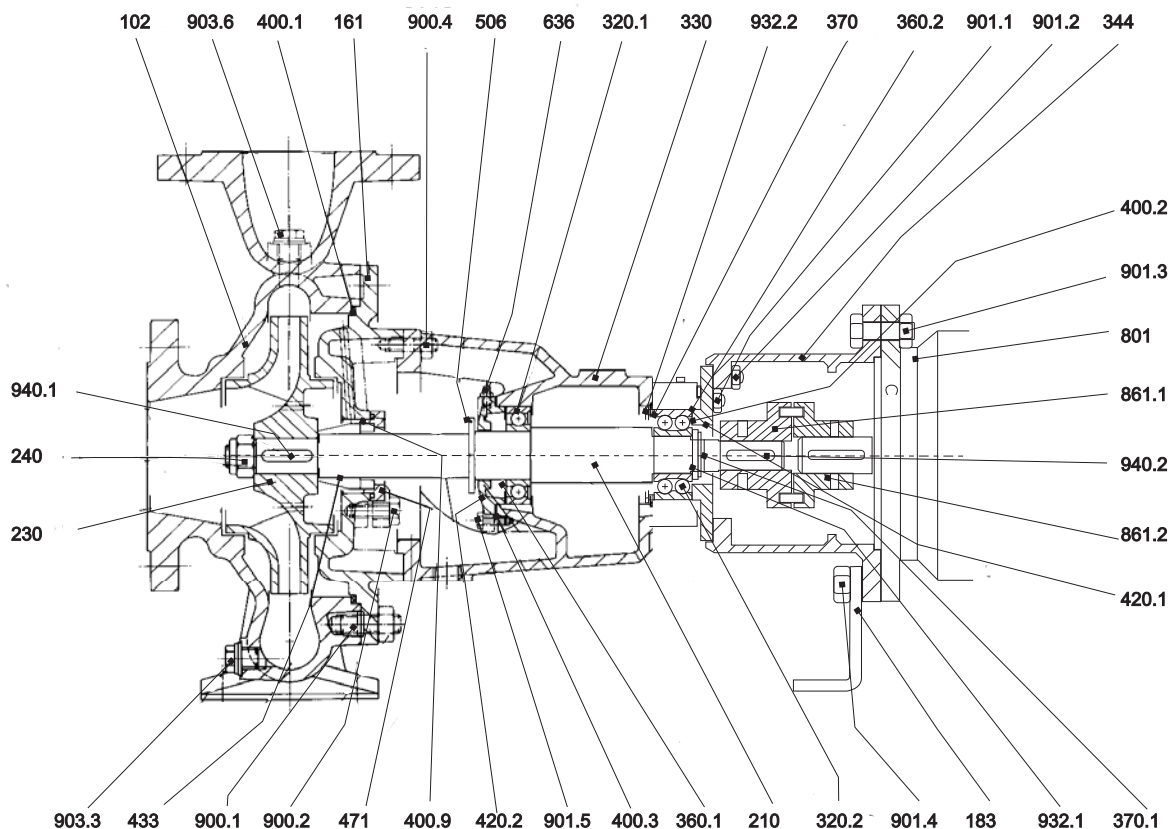

Nr	DESCRIZIONE	DESCRIPTION	Nr	DESCRIZIONE	DESCRIPTION
102	Corpo	Casing	471	Coperchio tenuta meccanica	Mechanical seal cover
161	Coperchio del corpo	Casing cover	506	Paraspruzzi	Deflector
183	Piede di appoggio	Support foot	636	Ingrassatore	Grease nipple
210	Albero	Shaft	801	Motore elettrico	Electric motor
230	Girante	Impeller	861.1	Semi giunto lato pompa	Half coupling pump side
240	Dado di bloccaggio girante	Impeller Nut	861.2	Semi giunto lato motore	Half coupling motor side
320.1	Cuscinetto a sfere l.o.c.	Ball bearing N.D.S.	900.1	Prigioniero con dado	Stud with nut
320.2	Cuscinetto a sfere l.c.	Ball bearing D.S.	900.2	Prigioniero con dado	Stud with nut
330	Supporto	Bearing housing	900.4	Prigioniero con dado	Stud with nut
344	Lanterna motore	Lantern bracket	901.1	Vite T.E.	Hex head srew
360.1	Coperchio cuscinetto l.o.c.	Bearing cover N.D.S.	901.2	Vite T.E.	Hex head srew
360.2	Coperchio cuscinetto l.c.	Bearing cover D.S.	901.3	Vite T.E.	Hex head srew
370	Distanziale cuscinetto	Bearing spacer	901.4	Vite T.E.	Hex head srew
370.1	Distanziale cuscinetto	Bearing spacer	901.5	Vite T.E.	Hex head srew
400.1	Guarnizione del corpo	Casing gasket	903.3	Tappo drenaggio	Drain plug
400.2	Guarnizione coperchio cuscinetto l.c.	Bearing cover gasketl D.S.	903.6	Tappo di adescamento con rondella	Primingplug & washer
400.3	Guarnizione coperchio cuscinetto l.o.c.	Bearing cover gasket N.D.S.	932.1	Seeger supporto	Circlip for a bore
400.9	Guarnizione tenuta meccanica	Mechanical seal gasket	932.2	Seeger albero	Circlip for a shaft
420.1	Anello di tenuta l.c.	Bearing cover seal D.S.	940.1	Linguetta girante	Impeller key
420.2	Anello di tenuta l.o.c.	Bearing cover seal N.D.S.	940.2	Linguetta giunto	Coupling key
433	Tenuta meccanica	Mechanical seal			

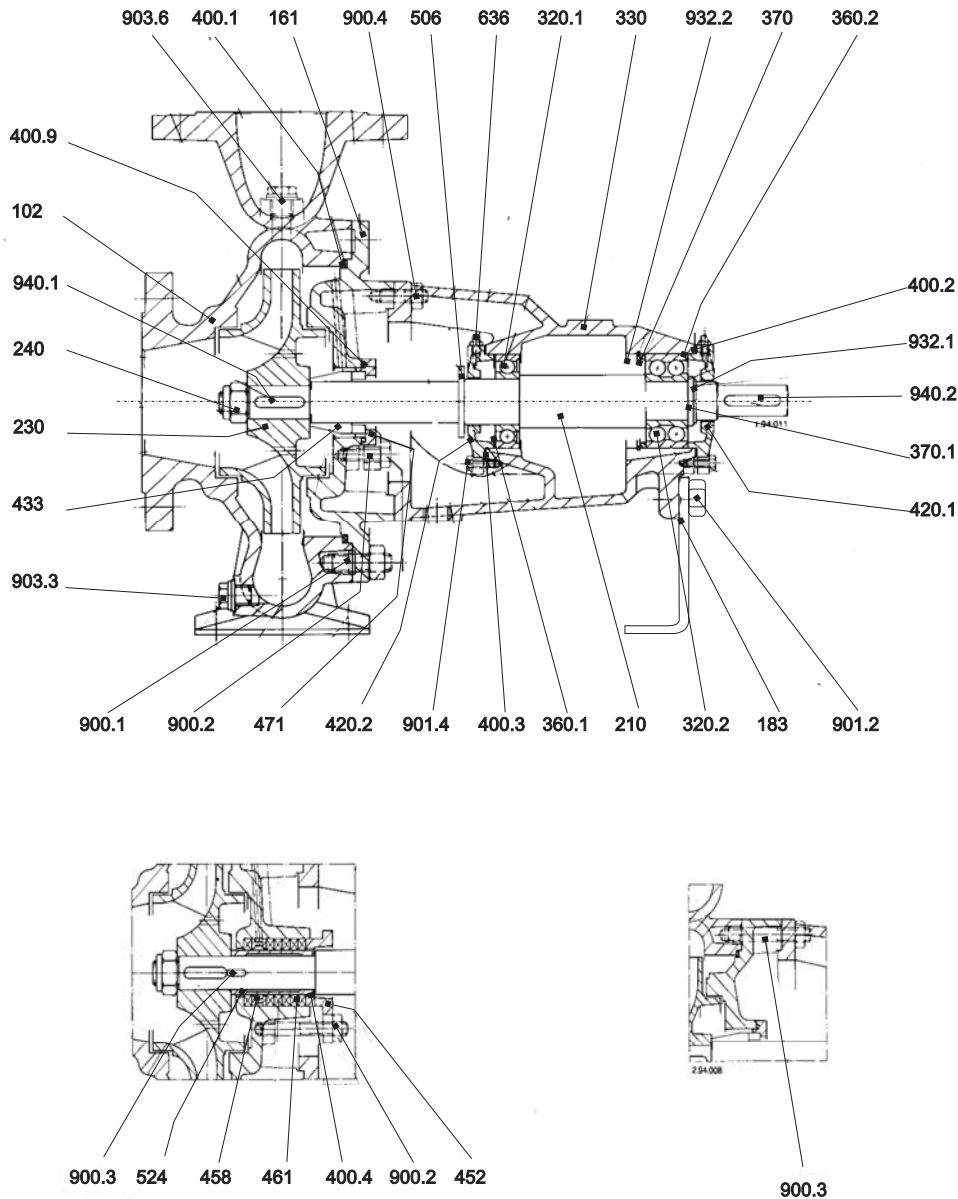

Nr	DESCRIZIONE	DESCRIPTION	Nr	DESCRIZIONE	DESCRIPTION
102	Corpo	Casing	452	Premitreccia	Packing gland
161	Coperchio del corpo	Casing cover	458	Anello idraulico	Lantern ring
183	Piede di appoggio	Support foot	433	Tenuta meccanica	Mechanical seal
210	Albero	Shaft	461	Baderna	Packing ring
230	Girante	Impeller	471	Coperchio tenuta meccanica	Mechanical seal cover
240	Dado di bloccaggio girante	Impeller Nut	506	Paraspruzzi	Deflector
320.1	Cuscinetto a sfere l.o.c.	Ball bearing N.D.S.	524	Camicia albero	Shaft sleeve
320.2	Cuscinetto a sfere l.c.	Ball bearing D.S.	636	Ingrassatore	Grease nipple
330	Supporto	Bearing housing	900.1	Prigioniero con dado	Stud with nut
360.1	Coperchio cuscinetto l.o.c.	Bearing cover N.D.S.	900.2	Prigioniero con dado	Stud with nut
360.2	Coperchio cuscinetto l.c.	Bearing cover D.S.	900.3	Prigioniero con dado	Stud with nut
370	Distanziale cuscinetto	Bearing spacer	900.4	Prigioniero con dado	Stud with nut
370.1	Distanziale cuscinetto	Bearing spacer	901.2	Vite T.E.	Hex head screw
400.1	Guarnizione del corpo	Casing gasket	901.4	Vite T.E.	Hex head screw
400.2	Guarnizione coperchio cuscinetto l.c.	Bearing cover gasketl D.S.	903.3	Tappo drenaggio	Drain plug
400.3	Guarnizione coperchio cuscinetto l.o.c.	Bearing cover gasket N.D.S.	903.6	Tappo di adescamento con rondella	Primingplug & washer
400.4	Guarnizione camicia	Sleeve gasket	932.1	Seeger supporto	Circlip for a bore
400.9	Guarnizione tenuta meccanica	Mechanical seal gasket	932.2	Seeger albero	Circlip for a shaft
420.1	Anello di tenuta l.c.	Bearing cover seal D.S.	940.1	Linguetta girante	Impeller key
420.2	Anello di tenuta l.o.c.	Bearing cover seal N.D.S.	940.2	Linguetta giunto	Coupling key

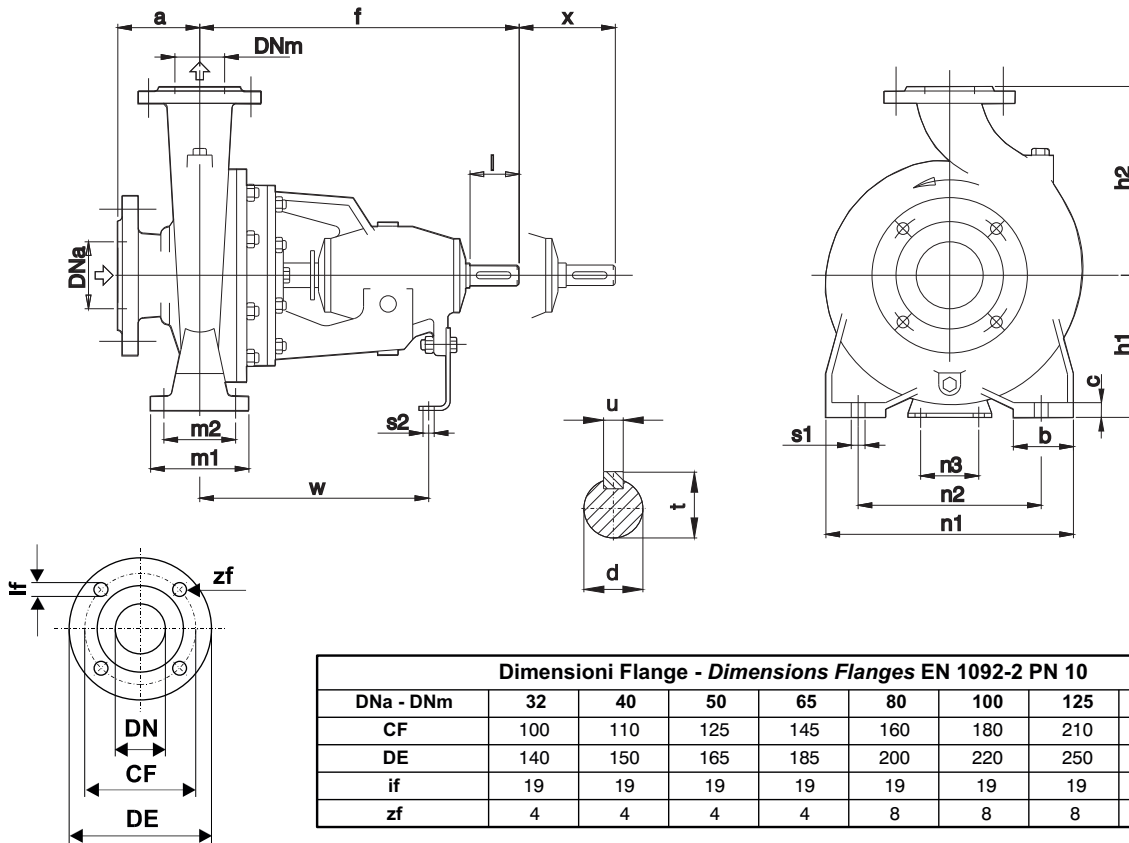

Pompa Tipo Pump Size RN	Supporto Bearing Housing	DIMENSIONI - DIMENSIONS [mm]																				Peso Weight [kg]	
		Pompa - Pump					Piedi - Feet					Albero - Shaft											
		DNa	DNm	a	f	h1	h2	b	c	m1	m2	n1	n2	n3	s1	s2	w	d	l	t	u		X ^(a)
32 - 125	32	50	32	80	360	112	140	50	14	100	70	190	140	110	14	14	260	24	50	27	8	100	31
32 - 160	32	50	32	80	360	132	160	50	18	100	70	240	190	110	14	14	260	24	50	27	8	100	38
32 - 200	32	50	32	80	360	160	180	50	18	100	70	240	190	110	14	14	260	24	50	27	8	100	45
40 - 125	32	65	40	80	360	112	140	50	18	100	70	210	160	110	14	14	260	24	50	27	8	100	34
40 - 160	32	65	40	80	360	132	160	50	18	100	70	240	190	110	14	14	260	24	50	27	8	100	40
40 - 200	32	65	40	100	360	160	180	50	18	100	70	265	212	110	14	14	260	24	50	27	8	100	48
40 - 250	32	65	40	100	360	180	225	65	19	125	95	320	250	110	14	14	260	24	50	27	8	100	62
50 - 125	32	65	50	100	360	132	160	50	18	100	70	240	190	110	14	14	260	24	50	27	8	100	44
50 - 160	32	65	50	100	360	160	180	50	18	100	70	265	212	110	14	14	260	24	50	27	8	100	46
50 - 200	32	65	50	100	360	160	200	50	18	100	70	265	212	110	14	14	260	24	50	27	8	100	52
50 - 250	32	65	50	100	360	180	225	65	19	125	95	320	250	110	14	14	260	24	50	27	8	100	64
65 - 125	32	80	65	100	360	160	180	65	19	125	95	280	212	110	14	14	260	24	50	27	8	100	52
65 - 160	32	80	65	100	360	160	200	65	19	125	95	280	212	110	14	14	260	24	50	27	8	100	52
65 - 200	32	80	65	100	360	180	225	65	19	125	95	320	250	110	14	14	260	24	50	27	8	140	60
65 - 250	40	80	65	100	470	200	250	80	23	160	120	360	280	110	18	14	340	32	80	35	10	140	95
65 - 315	40	80	65	125	470	225	280	80	23	160	120	400	315	110	18	14	340	32	80	35	10	140	136
80 - 160	32	100	80	125	360	180	225	65	19	125	95	320	250	110	14	14	260	24	50	27	8	140	63
80 - 200	40	100	80	125	470	180	250	65	19	125	95	345	280	110	14	14	260	24	50	27	8	140	90
80 - 250	40	100	80	125	470	200	280	80	23	160	120	400	315	110	18	14	340	32	80	35	10	140	112
80 - 315	40	100	80	125	470	250	315	80	23	160	120	400	315	110	18	14	340	32	80	35	10	140	139
80 - 400	50	125	80	125	530	280	355	80	16	160	120	435	355	110	18	14	340	42	80	35	10	140	202
100 - 200	40	125	100	125	470	200	280	80	23	160	120	360	280	110	18	14	340	32	80	35	10	140	102
100 - 250	40	125	100	140	470	225	280	80	23	160	120	400	315	110	18	14	340	32	80	35	10	140	121
100 - 315	40	125	100	140	470	250	315	80	16	160	120	400	315	110	18	14	340	32	80	35	10	140	151
100 - 400	50	125	100	140	530	280	355	100	20	200	150	500	400	110	22	14	370	42	110	45	12	140	211
125 - 250	40	150	125	140	470	250	355	80	23	160	120	400	315	110	18	14	340	32	80	35	10	140	140
125 - 315	50	150	125	140	530	280	355	100	20	200	200	500	400	110	22	14	370	42	110	45	12	140	198
125 - 400	50	150	125	140	530	315	400	100	20	200	200	500	400	110	22	14	370	42	110	45	12	140	232
150 - 315	50	200	150	160	530	280	400	100	20	200	200	550	450	110	22	14	370	42	110	45	12	140	213
150 - 400	50	200	150	160	530	315	450	100	20	200	200	550	450	110	22	14	370	42	110	45	12	140	262

Quote e pesi suscettibili di variazione.
Dimensions and weights are subject to variations.

^(a) Lunghezza del giunto spaziatore.
Spacer coupling's length.

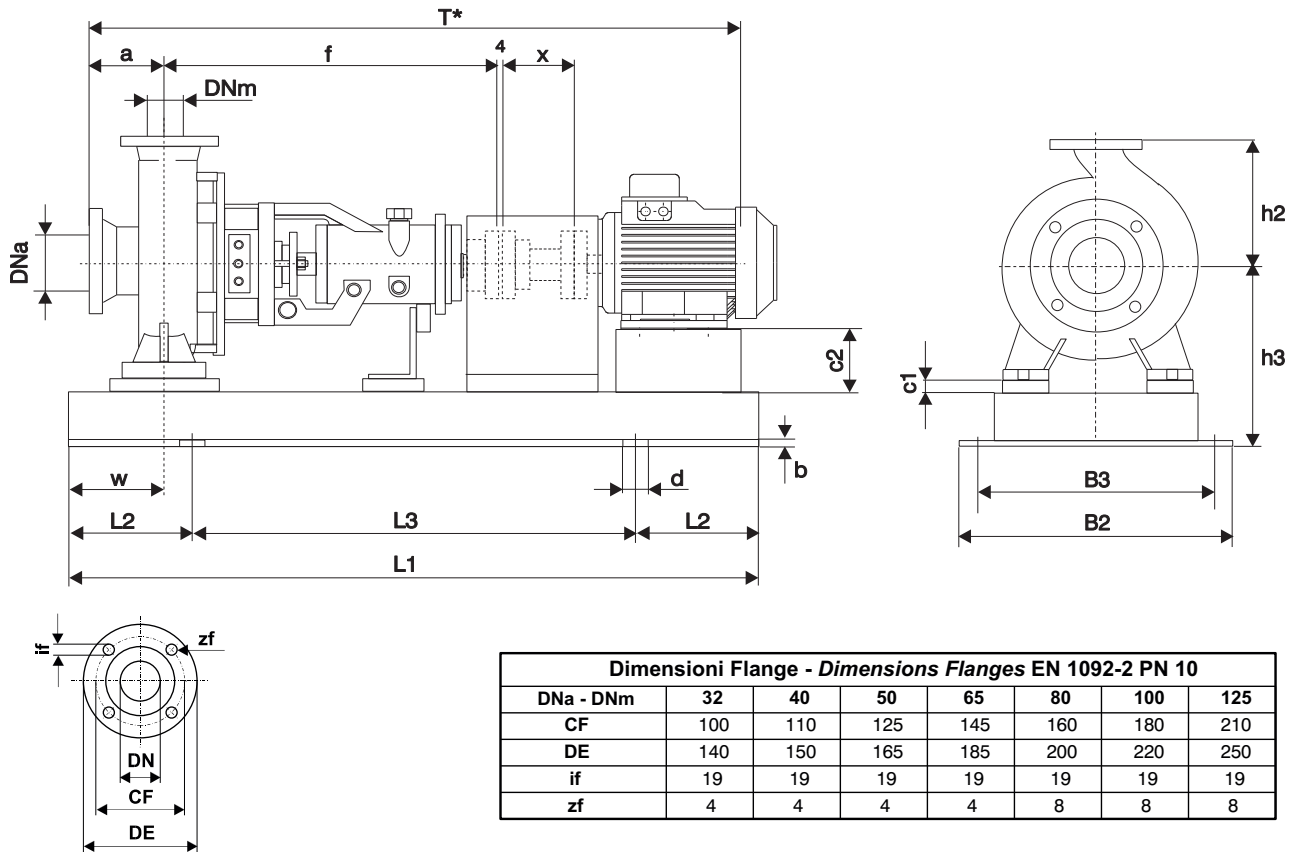
Lunghezza del giunto spaziatore - Spacer coupling length

Pompa tipo Pump size		32-125	32-160	32-200	40-125	40-160	40-200	40-250	50-125	50-160	50-200	50-250	65-125	65-160	65-200	65-250	65-315	80-160	80-200	80-250	80-315	80-400	100-200
Supporto Bearing housing	[mm]	32	32	32	32	32	32	32	32	32	32	40	32	40	40	40	40	40	40	40	40	50	40
X	[mm]	100	100	100	100	100	100	100	100	100	100	100	100	100	140	140	140	140	140	140	140	140	140

**ACCOPIAMENTO POTENZA - POLARITA' / GRANDEZZA MOTORE
POWER-POLARITY / MOTOR SIZE COUPLING**

2POLI	Grand.	71	80	80	90S	90L	100L	112M	132S	132M	132M	160M	160M	160L	180M	200L	200L	225M	250M	280S	280M	315S	315M												
	kW	0,55	0,75	1,1	1,5	2,2	3	4	5,5	7,5	9,2	11	15	18,5	22	30	37	45	55	75	90	110	132												
4POLI	Grand.	80	80	90S	90L	100L	100L	112M	132S	132M	132M	160M	160L	180M	180L	200L	225S	225M	250M	280S	280M	315S	315M	315M	315M	315L	355L	355L	355L	355L					
	kW	0,55	0,75	1,1	1,5	2,2	3	4	5,5	7,5	9,2	11	15	18,5	22	30	37	45	55	75	90	110	132	160	200	250	315	355							
6POLI	Grand.	80	90S	90L	100L	112M	132S	132M	132M	160M	160L	180L	200L	200L	225L	250M	280S	280M	315S	315M	315M	315M													
	kW	0,55	0,75	1,1	1,5	2,2	3	4	5,5	7,5	11	15	18,5	22	30	37	45	55	75	90	110	132													

Pompa tipo Pump size	Motore - Motor		Base Base- Plate n.°	DIMENSIONI - DIMENSIONS [mm]																	Peso Weight [kg]
	Grand. Size	KW		DNa	DNm	a	f	h3	h2	L1	L2	L3	B2	B3	w	d	b	c1	c2	T ^(a)	
RN 32/125F	71	0,55	1	50	32	80	360	172	140	750	120	510	350	320	60	19	30	0	41	785	55
RN 32/125D	80	0,75	1	"	"	"	"	"	"	"	"	"	"	"	60	"	"	0	32	815	60
RN 32/125A	80	1,1	1	"	"	"	"	"	"	"	"	"	"	"	60	"	"	0	32	815	61
RN 32/125S	90S	1,5	2	"	"	"	"	232	"	1000	170	550	400	360	60	"	"	0	22	840	65
RN 32/160B	90S	1,5	2	50	32	80	360	192	160	1000	170	550	400	360	60	19	30	0	42	840	70
RN 32/160A	90L	2,2	2	"	"	"	"	"	"	"	"	"	"	"	60	"	"	0	42	865	75
RN 32/200D	90L	2,2	2	50	32	80	360	220	180	1000	170	550	400	360	60	19	30	0	70	865	80
RN 32/200C	100L	3	2	"	"	"	"	"	"	"	"	"	"	"	60	"	"	0	60	905	85
RN 32/200A	112M	4	2	"	"	"	"	"	"	"	"	"	"	"	60	"	"	0	48	905	90

Pompa tipo Pump size	Motore - Motor		Base Base- Plate n.°	DIMENSIONI - DIMENSIONS [mm]																	Peso ^(a) Weight [kg]
	Grand. Size	KW		DNa	DNm	a	f	h3	h2	L1	L2	L3	B2	B3	w	d	b	c1	c2	T ^(a)	
RN 40/125F	80	1,1	1	65	40	80	360	172	140	750	120	510	350	320	60	19	30	0	32	815	65
RN 40/125C	90S	1,5	2	"	"	"	"	232	"	1000	170	660	400	360	60	"	"	0	22	840	65
RN 40/125A	90L	2,2	2	"	"	"	"	"	"	"	"	"	"	"	60	"	"	0	22	865	70
RN 40/160C	90L	2,2	2	65	40	80	360	232	160	1000	170	660	400	360	60	19	30	0	42	865	75
RN 40/160B	100L	3	2	"	"	"	"	"	"	"	"	"	"	"	60	"	"	0	32	905	80
RN 40/160A	112M	4	2	"	"	"	"	"	"	"	"	"	"	"	60	"	"	0	20	905	85
RN 40/200C	112M	4	2	65	40	100	360	280	180	1000	170	660	400	360	60	19	30	0	48	925	95
RN 40/200B	132S	5,5	2	"	"	"	"	"	"	"	"	"	"	"	60	"	"	0	28	1010	130
RN 40/200AR	132S	5,5	2	"	"	"	"	"	"	"	"	"	"	"	60	"	"	0	28	1010	130
RN 40/200A	132S	7,5	2	"	"	"	"	"	"	"	"	"	"	"	60	"	"	0	28	1010	135
RN 40/250B	160M	11	3	65	40	100	360	300	225	1200	205	790	440	400	75	19	30	0	20	1165	180
RN 40/250A	160M	15	3	"	"	"	"	"	"	"	"	"	"	"	75	"	"	0	20	1165	190
RN 50/125F	90L	2,2	2	65	50	100	360	252	160	1000	170	660	400	360	60	19	30	0	42	885	80
RN 50/125D	100L	3	2	"	"	"	"	"	"	"	"	"	"	"	60	"	"	0	32	925	85
RN 50/125A	112M	4	2	"	"	"	"	"	"	"	"	"	"	"	60	"	"	0	20	925	90
RN 50/160B	132S	5,5	2	65	50	100	360	280	180	1000	170	660	400	360	60	19	30	0	28	1010	125
RN 50/160A	132S	7,5	2	"	"	"	"	"	"	"	"	"	"	"	60	"	"	0	28	1010	130
RN 50/200B	132M	9,2	2	65	50	100	360	280	200	1000	170	660	400	360	60	19	30	0	28	1010	145
RN 50/200A	160M	11	3	"	"	"	"	"	"	1200	205	790	440	400	60	"	"	0	0	1165	170
RN 50/250B	160M	15	3	65	50	100	360	300	225	1200	205	790	440	400	75	19	30	0	20	1165	195
RN 50/250A	160L	18,5	3	"	"	"	"	"	"	"	"	"	"	"	75	"	"	0	20	1165	205
RN 65/125E	112M	4	2	80	65	100	360	280	180	1000	170	660	400	360	75	19	30	0	48	925	120
RN 65/125C	132S	5,5	2	"	"	"	"	"	"	"	"	"	"	"	75	"	"	0	28	1010	135
RN 65/125A	132S	7,5	2	"	"	"	"	"	"	"	"	"	"	"	75	"	"	0	28	1010	140
RN 65/160E	132S	5,5	2	80	65	100	360	280	200	1000	170	660	400	360	75	19	30	0	28	1010	135
RN 65/160D	132S	7,5	2	"	"	"	"	"	"	"	"	"	"	"	75	"	"	0	28	1010	140
RN 65/160C	132M	9,2	2	"	"	"	"	"	"	"	"	"	"	"	75	"	"	0	28	1010	145
RN 65/160B	160M	11	3	"	"	"	"	"	"	1200	205	790	440	400	75	"	"	0	0	1165	170
RN 65/160A	160M	15	3	"	"	"	"	"	"	"	"	"	"	"	75	"	"	0	0	1165	180
RN 65/200C	160M	15	3	80	65	100	360	300	225	1200	205	790	440	400	75	19	30	0	20	1165	190
RN 65/200B	160L	18,5	3	"	"	"	"	"	"	"	"	"	"	"	75	"	"	0	20	1165	200
RN 65/200A	180M	22	3	"	"	"	"	"	"	"	"	"	"	"	75	"	"	0	0	1245	230
RN 65/250C	180M	22	4	80	65	100	470	320	250	1500	245	1010	480	440	90	19	30	0	20	1355	265
RN 65/250B	200L	30	4	"	"	"	"	"	"	"	"	"	"	"	90	"	"	0	0	1450	335
RN 65/250A	200L	37	4	"	"	"	"	"	"	"	"	"	"	"	90	"	"	0	0	1450	360
RN 80/160E	132S	7,5	2	100	80	125	360	300	225	1000	170	660	400	360	75	19	30	0	48	1035	150
RN 80/160D	132M	9,2	2	"	"	"	"	"	"	"	"	"	"	"	75	"	"	0	48	1035	155
RN 80/160C	160M	11	3	"	"	"	"	"	"	1200	205	790	440	400	75	"	"	0	20	1190	180
RN 80/160B	160M	15	3	"	"	"	"	"	"	"	"	"	"	"	75	"	"	0	20	1190	190
RN 80/160A	160L	18,5	3	"	"	"	"	"	"	"	"	"	"	"	75	"	"	0	20	1190	200
RN 80/160A	180M	22	3	"	"	"	"	"	"	"	"	"	"	"	75	"	"	0	0	1283	240
RN 80/200B	180M	22	3	100	80	125	470	300	250	1200	205	790	440	400	75	19	30	0	0	1380	260
RN 80/200A	200L	30	6	"	"	"	"	365	"	1300	215	870	510	460	90	24	13	20	0	1475	330
RN 80/250E	180M	22	6	100	80	125	470	365	280	1300	215	870	540	460	90	24	13	0	20	1380	285
RN 80/250D	200L	30	6	"	"	"	"	"	"	"	"	"	"	"	90	"	"	0	0	1475	340
RN 80/250C	200L	37	6	"	"	"	"	"	"	"	"	"	"	"	90	"	"	0	0	1475	365
RN 80/250B	225M	45	7	"	"	"	"	390	"	1450	235	980	560	510	90	"	"	50	25	1535	405
RN 80/250A	250M	55	7	"	"	"	"	415	"	"	"	"	"	"	90	"	"	75	25	1570	455
RN 100/200E	160L	18,5	4	125	100	125	470	320	280	1500	245	1010	480	440	90	19	30	0	40	1300	250
RN 100/200D	180M	22	4	"	"	"	"	"	"	"	"	"	"	"	90	"	"	0	20	1380	275
RN 100/200C	200L	30	4	"	"	"	"	"	"	"	"	"	"	"	90	"	"	0	0	1475	340
RN 100/200B	200L	37	4	"	"	"	"	"	"	"	"	"	"	"	90	"	"	0	0	1475	365
RN 100/200A	225M	45	7	"	"	"	"	390	"	1450	235	980	560	510	90	24	13	50	25	1535	395
RN 100/250B	250M	55	7	125	100	140	470	415	280	1450	235	980	560	510	90	24	13	50	25	1585	465
RN 100/250A	280S	75	8	"	"	"	"	445	"	1590	"	1120	"	"	"	"	80	25	1585	665	

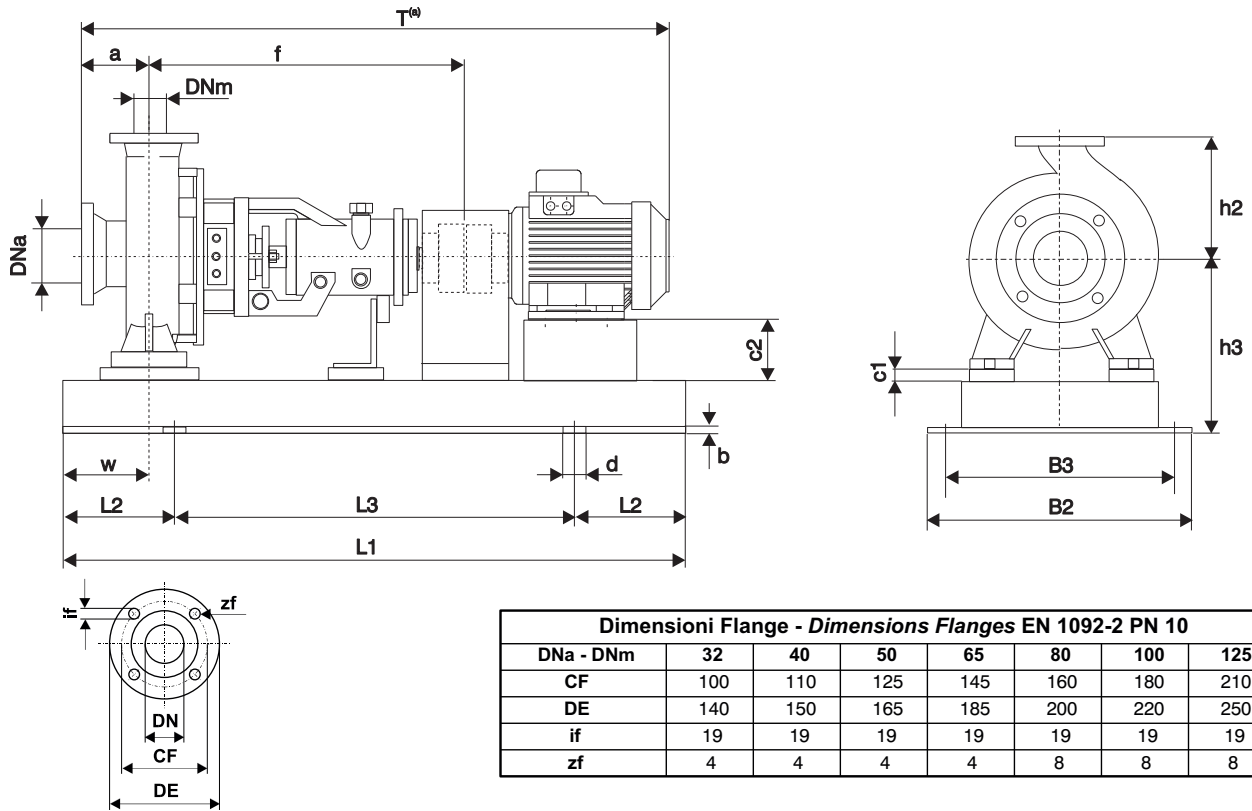

		ACCOPIAMENTO POTENZA - POLARITA' / GRANDEZZA MOTORE POWER-POLARITY / MOTOR SIZE COUPLING																																							
2POLI	Grand.	71	80	80	90S	90L	100L	112M	132S	132S	132M	160M	160M	160L	180M	200L	200L	225M	250M	280S	280M	315S	315M																		
	kW	0,55	0,75	1,1	1,5	2,2	3	4	5,5	7,5	9,2	11	15	18,5	22	30	37	45	55	75	90	110	132																		
4POLI	Grand.	80	80	90S	90L	100L	100L	112M	132S	132M	132M	160M	160L	180M	180L	200L	225S	225M	250M	280S	280M	315S	315M	315M	315L	355L	355L	355L	355L												
	kW	0,55	0,75	1,1	1,5	2,2	3	4	5,5	7,5	9,2	11	15	18,5	22	30	37	45	55	75	90	110	132	160	200	250	315	355													
6POLI	Grand.	80	90S	90L	100L	112M	132S	132M	132M	160M	160L	180L	200L	200L	225L	250M	280S	280M	315S	315M	315M	315M																			
	kW	0,55	0,75	1,1	1,5	2,2	3	4	5,5	7,5	11	15	18,5	22	30	37	45	55	75	90	110	132																			

Pompa tipo Pump size	Motore - Motor		Base Base- Plate n.°	DIMENSIONI - DIMENSIONS [mm]																			Peso ^(a) Weight [kg]
	Grand. Size	KW		DNa	DNm	a	f	h3	h2	L1	L2	L3	B2	B3	w	d	b	c1	c2	T ^(a)			
RN 32/125F	71	0,55	1	50	32	80	360	172	140	750	120	510	350	320	60	14	30	0	41	685	55		
RN 32/125D	80	0,75	1	"	"	"	"	"	"	"	"	"	"	"	60	"	"	0	32	715	60		
RN 32/125A	80	1,1	1	"	"	"	"	"	"	"	"	"	"	"	60	"	"	0	32	715	61		
RN 32/125S	90S	1,5	1	"	"	"	"	"	"	"	"	"	"	"	60	"	"	0	22	740	65		
RN 32/160B	90S	1,5	1	50	32	80	360	192	160	750	120	510	350	320	60	14	30	0	42	740	70		
RN 32/160A	90L	2,2	1	"	"	"	"	"	"	"	"	"	"	"	60	"	"	0	42	765	75		
RN 32/200D	90L	2,2	1	50	32	80	360	220	180	750	120	510	350	320	60	14	30	0	70	765	80		
RN 32/200C	100L	3	1	"	"	"	"	"	"	"	"	"	"	"	60	"	"	0	60	805	85		
RN 32/200A	112M	4	1	"	"	"	"	"	"	"	"	"	"	"	60	"	"	0	48	805	90		

Pompa tipo Pump size	Motore - Motor		Base Base- Plate n.°	DIMENSIONI - DIMENSIONS [mm]																	Peso ^(a) Weight [kg]
	Grand. Size	KW		DNa	DNm	a	f	h3	h2	L1	L2	L3	B2	B3	w	d	b	c1	c2	T ^(a)	
RN 40/125F	80	1,1	1	65	40	80	360	172	140	750	120	510	350	320	60	14	30	0	32	715	65
RN 40/125C	90S	1,5	1	"	"	"	"	"	"	"	"	"	"	"	60	"	"	0	22	740	65
RN 40/125A	90L	2,2	1	"	"	"	"	"	"	"	"	"	"	"	60	"	"	0	22	765	70
RN 40/160C	90L	2,2	1	65	40	80	360	192	160	750	120	510	350	320	60	14	30	0	42	765	75
RN 40/160B	100L	3	1	"	"	"	"	"	"	"	"	"	"	"	60	"	"	0	32	805	80
RN 40/160A	112M	4	1	"	"	"	"	"	"	"	"	"	"	"	60	"	"	0	20	805	85
RN 40/200C	112M	4	1	65	40	100	360	220	180	750	120	510	350	320	60	14	30	0	48	825	95
RN 40/200B	132S	5,5	2	"	"	"	"	280	"	1000	170	660	400	360	60	19	30	0	28	910	130
RN 40/200AR	132S	5,5	2	"	"	"	"	"	"	"	"	"	"	"	60	"	"	0	28	910	130
RN 40/200A	132S	7,5	2	"	"	"	"	"	"	"	"	"	"	"	60	"	"	0	28	910	135
RN 40/250B	160M	11	3	65	40	100	360	300	225	1200	205	790	440	400	75	19	30	0	20	1065	180
RN 40/250A	160M	15	3	"	"	"	"	"	"	"	"	"	"	"	75	"	"	0	20	1065	190
RN 50/125F	90L	2,2	1	65	50	100	360	192	160	750	120	510	350	320	60	14	30	0	42	785	80
RN 50/125D	100L	3	1	"	"	"	"	"	"	"	"	"	"	"	60	"	"	0	32	825	85
RN 50/125A	112M	4	1	"	"	"	"	"	"	"	"	"	"	"	60	"	"	0	20	825	90
RN 50/160B	132S	5,5	2	65	50	100	360	280	180	1000	170	660	400	360	60	19	30	0	28	910	125
RN 50/160A	132S	7,5	2	"	"	"	"	"	"	"	"	"	"	"	60	"	"	0	28	910	130
RN 50/200B	132M	9,2	2	65	50	100	360	280	200	1000	170	660	400	360	60	19	30	0	28	910	145
RN 50/200A	160M	11	3	"	"	"	"	"	"	1200	205	790	440	400	60	"	"	0	0	1065	170
RN 50/250B	160M	15	3	65	50	100	360	300	225	1200	205	790	440	400	75	19	30	0	20	1065	195
RN 50/250A	160L	18.5	3	"	"	"	"	"	"	"	"	"	"	"	75	"	"	0	20	1065	205
RN 65/125E	112M	4	1	80	65	100	360	220	180	750	120	510	350	320	75	19	30	0	48	825	120
RN 65/125C	132S	5.5	2	"	"	"	"	280	"	1000	170	660	400	360	75	"	"	0	28	910	135
RN 65/125A	132S	7.5	2	"	"	"	"	"	"	"	"	"	"	"	75	"	"	0	28	910	140
RN 65/160E	132S	5.5	2	80	65	100	360	280	200	1000	170	660	400	360	75	19	30	0	28	910	135
RN 65/160D	132S	7.5	2	"	"	"	"	"	"	"	"	"	"	"	75	"	"	0	28	910	140
RN 65/160C	132M	9.2	2	"	"	"	"	"	"	"	"	"	"	"	75	"	"	0	28	910	145
RN 65/160B	160M	11	3	"	"	"	"	"	"	1200	205	790	440	400"	75	"	"	0	0	1065	170
RN 65/160A	160M	15	3	"	"	"	"	"	"	"	"	"	"	"	75	"	"	0	0	1065	180
RN 65/200C	160M	15	3	80	65	100	360	300	225	1200	205	790	440	400	75	19	30	0	20	1065	190
RN 65/200B	160L	18.5	3	"	"	"	"	"	"	"	"	"	"	"	75	"	"	0	20	1065	200
RN 65/200A	180M	22	3	"	"	"	"	"	"	"	"	"	"	"	75	"	"	0	0	1145	230
RN 65/250C	180M	22	3	80	65	100	470	320	250	1200	205	790	440	400	90	19	30	0	20	1255	265
RN 65/250B	200L	30	5	"	"	"	"	"	"	"	"	"	505	465	90	"	"	0	0	1350	335
RN 65/250A	200L	37	5	"	"	"	"	"	"	"	"	"	"	"	90	"	"	0	0	1350	360
RN 80/160E	132S	7.5	2	100	80	125	360	300	225	1000	170	660	400	360	75	19	30	0	48	935	150
RN 80/160D	132M	9.2	2	"	"	"	"	"	"	"	"	"	"	"	75	"	"	0	48	935	155
RN 80/160C	160M	11	3	"	"	"	"	"	"	1200	205	790	440	400	75	"	"	0	20	1090	180
RN 80/160B	160M	15	3	"	"	"	"	"	"	"	"	"	"	"	75	"	"	0	20	1090	190
RN 80/160A	160L	18.5	3	"	"	"	"	"	"	"	"	"	"	"	75	"	"	0	20	1090	200
RN 80/160A	180M	22	3	"	"	"	"	"	"	"	"	"	"	"	75	"	"	0	0	1183	240
RN 80/200B	180M	22	3	100	80	125	470	300	250	1200	205	790	440	400	75	19	30	0	0	1280	260
RN 80/200A	200L	30	5	"	"	"	"	320	"	"	"	"	505	465	75	"	"	20	0	1375	330
RN 80/250E	180M	22	5	100	80	125	470	320	280	1200	205	790	505	465	90	19	30	0	20	1280	285
RN 80/250D	200L	30	5	"	"	"	"	"	"	"	"	"	"	"	90	"	"	0	0	1375	340
RN 80/250C	200L	37	5	"	"	"	"	"	"	"	"	"	"	"	90	"	"	0	0	1375	365
RN 80/250B	225M	45	6	"	"	"	"	365	"	1300	215	870	540	460	90	24	15	50	25	1435	405
RN 80/250A	250M	55	6	"	"	"	"	415	"	"	"	"	"	"	90	"	"	75	25	1470	455
RN 100/200E	160L	18.5	3	125	100	125	470	320	280	1200	205	790	440	400	90	19	30	0	40	1200	250
RN 100/200D	180M	22	3	"	"	"	"	"	"	"	"	"	"	"	90	"	"	0	20	1280	275
RN 100/200C	200L	30	5	"	"	"	"	"	"	"	"	"	505	465	90	"	"	0	0	1375	340
RN 100/200B	200L	37	5	"	"	"	"	"	"	"	"	"	"	"	90	"	"	0	0	1375	365
RN 100/200A	225M	45	6	"	"	"	"	390	"	1300	215	870	540	460	90	24	15	50	25	1435	395
RN 100/250B	250M	55	6	125	100	140	470	415	280	1300	215	870	540	460	90	24	15	50	25	1485	465
RN 100/250A	280S	75	7	"	"	"	"	445	"	1450	235	980	560	510	90	"	"	80	25	1485	665

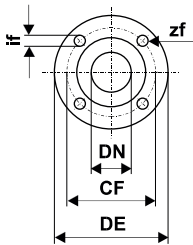
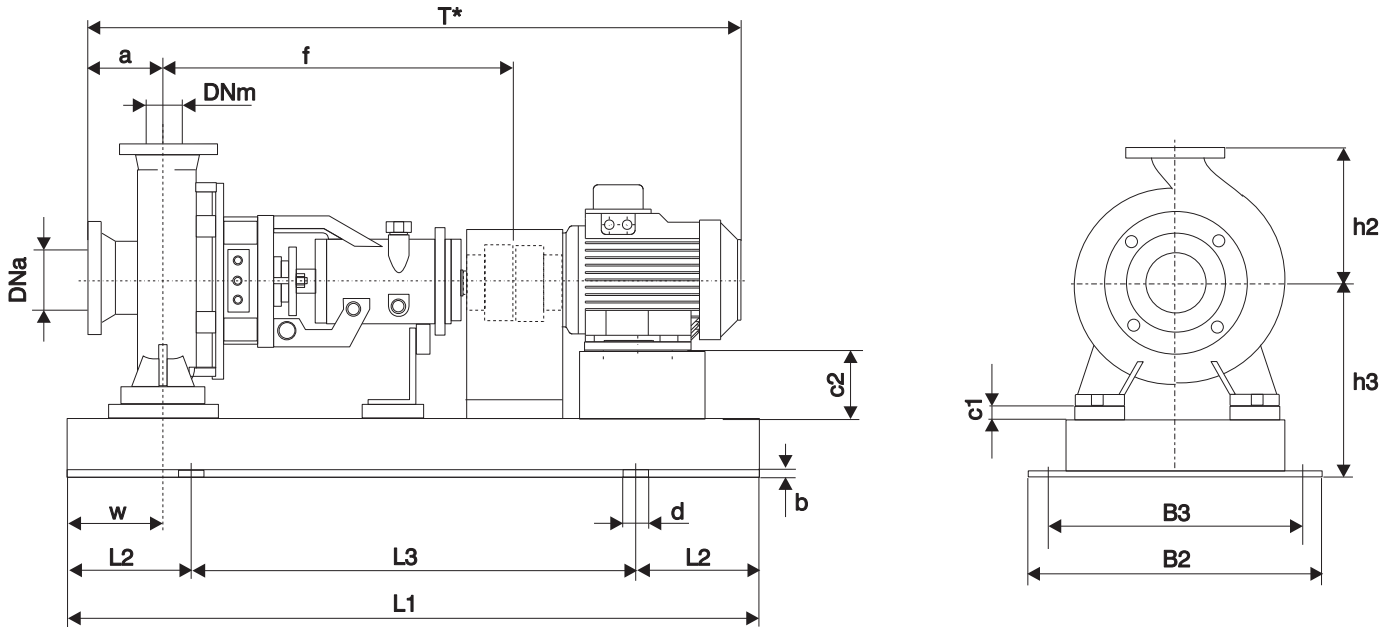
Dimensioni Flange - Dimensions Flanges EN 1092-2 PN 10

DNa - DNm	32	40	50	65	80	100	125	150	200
CF	100	110	125	145	160	180	210	240	295
DE	140	150	165	185	200	220	250	285	340
if	19	19	19	19	19	19	19	23	23
zf	4	4	4	4	8	8	8	8	8

**ACCOPPIAMENTO POTENZA - POLARITA' / GRANDEZZA MOTORE
POWER-POLARITY / MOTOR SIZE COUPLING**

POLI	Grand.	POTENZA (kW)																				GRANDEZZA MOTORE (mm)					
		71	80	80	90S	90L	100L	112M	132S	132S	132M	160M	160M	160L	180M	200L	200L	225M	250M	280S	280M	315S	315M				
2POLI	kW	0,55	0,75	1,1	1,5	2,2	3	4	5,5	7,5	9,2	11	15	18,5	22	30	37	45	55	75	90	110	132				
	Grand.	80	80	90S	90L	100L	100L	112M	132S	132M	132M	160M	160L	180M	180L	200L	225S	225M	250M	280S	280M	315S	315M	315M	315L	355L	355L
4POLI	kW	0,55	0,75	1,1	1,5	2,2	3	4	5,5	7,5	9,2	11	15	18,5	22	30	37	45	55	75	90	110	132	160	200	250	315
	Grand.	80	90S	90L	100L	112M	132S	132M	132M	160M	160L	180L	200L	200L	225L	250M	280S	280M	315S	315M	315M						
6POLI	kW	0,55	0,75	1,1	1,5	2,2	3	4	5,5	7,5	11	15	18,5	22	30	37	45	55	75	90	110	132					
	Grand.	80	90S	90L	100L	112M	132S	132M	132M	160M	160L	180L	200L	200L	225L	250M	280S	280M	315S	315M	315M						

Pompa tipo Pump size	Motore - Motor		Base Base- Plate n.°	DIMENSIONI - DIMENSIONS [mm]																	Peso ^(a) Weight [kg]
	Grand. Size	KW		DNa	DNm	a	f	h3	h2	L1	L2	L3	B2	B3	w	d	b	c1	c2	T ^(a)	
RN4 32/125F	71	0.25	1	50	32	80	360	172	140	750	120	510	350	320	60	14	30	0	41	685	55
RN4 32/125D	71	0.25	1	"	"	"	"	"	"	"	"	"	"	"	60	"	"	0	41	685	55
RN4 32/125A	71	0.25	1	"	"	"	"	"	"	"	"	"	"	"	60	"	"	0	41	685	55
RN4 32/160B	71	0.37	1	50	32	80	360	192	160	750	120	510	350	320	60	14	30	0	61	685	65
RN4 32/160A	71	0.37	1	"	"	"	"	"	"	"	"	"	"	"	60	"	"	0	61	685	65
RN4 32/200B	80	0.55	1	50	32	80	360	220	180	750	120	510	350	320	60	14	30	0	80	715	75
RN4 32/200A	80	0.75	1	"	"	"	"	"	"	"	"	"	"	"	60	"	"	0	80	715	75
RN4 40/125F	71	0.25	1	65	40	80	360	172	140	750	120	510	350	320	60	14	30	0	41	685	60
RN4 40/125C	71	0.37	1	"	"	"	"	"	"	"	"	"	"	"	60	"	"	0	41	685	60
RN4 40/125A	71	0.37	1	"	"	"	"	"	"	"	"	"	"	"	60	"	"	0	41	685	60
RN4 40/160C	71	0.37	1	65	40	80	360	192	160	750	120	510	350	320	60	14	30	0	41	685	65
RN4 40/160B	80	0.55	1	"	"	"	"	"	"	"	"	"	"	"	60	"	"	0	52	715	70
RN4 40/160A	80	0.75	1	"	"	"	"	"	"	"	"	"	"	"	60	"	"	0	52	715	70
RN4 40/200B	90S	1.1	1	65	40	100	360	220	180	750	120	510	350	320	60	14	30	0	70	760	80
RN4 40/200A	90S	1.1	1	"	"	"	"	"	"	"	"	"	"	"	60	"	"	0	70	760	80
RN4 40/250C	90L	1.5	2	65	40	100	360	300	225	1000	170	660	400	360	75	19	30	0	90	785	125
RN4 40/250B	100L	2.2	2	"	"	"	"	"	"	"	"	"	"	"	75	"	"	0	80	825	130
RN4 40/250A	100L	3	2	"	"	"	"	"	"	"	"	"	"	"	75	"	"	0	80	825	130
RN4 50/125F	71	0.37	1	65	50	100	360	192	160	750	120	510	350	320	60	14	30	0	61	705	70
RN4 50/125D	80	0.55	1	"	"	"	"	"	"	"	"	"	"	"	60	"	"	0	52	735	70
RN4 50/125A	80	0.75	1	"	"	"	"	"	"	"	"	"	"	"	60	"	"	0	52	735	75
RN4 50/125S	80	0.75	1	"	"	"	"	"	"	"	"	"	"	"	60	"	"	0	52	735	75
RNA 50/160B	90S	1.1	1	65	50	100	360	220	180	750	120	510	350	320	60	14	30	0	70	760	80
RN4 50/160A	90S	1.1	1	"	"	"	"	"	"	"	"	"	"	"	60	"	"	0	70	760	80
RN4 50/200C	90S	1.1	1	65	50	100	360	220	200	750	120	510	350	320	60	14	30	0	70	760	85
RN4 50/200B	90L	1.5	1	"	"	"	"	"	"	"	"	"	"	"	60	"	"	0	70	785	90
RN4 50/200A	100L	2.2	1	"	"	"	"	"	"	"	"	"	"	"	75	"	"	0	60	825	95
RN4 50/250C	100L	2.2	2	65	50	100	360	300	225	1000	170	660	400	360	75	19	30	0	80	825	130
RN4 50/250B	100L	3	2	"	"	"	"	"	"	"	"	"	"	"	75	"	"	0	80	825	135
RN4 50/250A	112M	4	2	"	"	"	"	"	"	"	"	"	"	"	75	"	"	0	68	825	135
RN4 65/125E	80	0.75	1	80	65	100	360	220	180	750	120	510	350	320	75	19	30	0	80	735	90
RN4 65/125C	80	0.75	1	"	"	"	"	"	"	"	"	"	"	"	75	"	"	0	80	735	90
RN4 65/125A	90S	1.1	1	"	"	"	"	"	"	"	"	"	"	"	75	"	"	0	70	760	95
RN4 65/160C	90S	1.1	1	80	65	100	360	220	200	750	120	510	350	320	75	19	30	0	70	760	95
RN4 65/160B	90S	1.1	1	"	"	"	"	"	"	"	"	"	"	"	75	"	"	0	70	760	95
RN4 65/160A	90L	1.5	1	"	"	"	"	"	"	"	"	"	"	"	75	"	"	0	70	785	100
RN4 65/200B	100L	2.2	2	80	65	100	360	300	225	1000	170	660	400	360	75	19	30	0	80	825	125
RN4 65/200A	100L	3	2	"	"	"	"	"	"	"	"	"	"	"	75	"	"	0	80	825	130
RN4 65/250B	112M	4	3	80	65	100	470	320	250	1200	205	790	440	400	90	19	30	0	88	935	175
RN4 65/250A	132 S	5.5	3	"	"	"	"	"	"	"	"	"	"	"	90	"	"	0	68	1020	190
RN4 65/315C	132 S	5.5	5	80	65	125	470	345	280	1200	205	790	505	465	90	19	30	0	93	1045	230
RN4 65/315B	132M	7.5	5	"	"	"	"	"	"	"	"	"	"	"	90	"	"	0	93	1045	235
RN4 65/315A	132M	9.2	5	"	"	"	"	"	"	"	"	"	"	"	90	"	"	0	93	1045	240
RN4 80/160C	90S	1.1	2	100	80	125	360	300	225	1000	170	660	400	360	75	19	30	0	90	785	120
RN4 80/160B	90L	1.5	2	"	"	"	"	"	"	"	"	"	"	"	75	"	"	0	90	810	125
RN4 80/160A	100L	2.2	2	"	"	"	"	"	"	"	"	"	"	"	75	"	"	0	80	850	130
RN4 80/200C	100L	2.2	3	100	80	125	470	300	250	1200	205	790	440	400	75	19	30	0	80	960	165
RN4 80/200B	100L	3	3	"	"	"	"	"	"	"	"	"	"	"	75	"	"	0	80	960	165
RN4 80/200A	112M	4	3	"	"	"	"	"	"	"	"	"	"	"	75	"	"	0	68	960	170
RN4 80/250C	112M	4	5	100	80	125	470	320	280	1200	205	790	505	465	90	19	30	0	88	960	190
RN4 80/250B	132S	5.5	5	"	"	"	"	"	"	"	"	"	"	"	90	"	"	0	68	1045	205
RN4 80/250A	132M	7.5	5	"	"	"	"	"	"	"	"	"	"	"	90	"	"	0	68	1045	215

Pompa tipo Pump size	Motore - Motor		Base Base- Plate n.°	DIMENSIONI - DIMENSIONS [mm]																	Peso ^(a) Weight [kg]
	Grand. Size	KW		DNa	Dnm	a	f	h3	h2	L1	L2	L3	B2	B3	w	d	b	c1	c2	T ^(a)	
RN4 80/315C	132M	9.2	5	100	80	125	470	370	315	1200	205	790	505	465	90	19	30	0	118	1045	240
RN4 80/315B	160M	11	5	"	"	"	"	"	"	"	"	"	"	"	90	"	"	0	90	1200	270
RN4 80/315A	160L	15	5	"	"	"	"	"	"	"	"	"	"	"	90	"	"	0	90	1245	285
RN4 80/400C	180M	18.5	6	125	80	125	530	445	355	1300	215	870	510	460	90	24	13	25	125	1360	405
RN4 80/400B	180L	22	6	"	"	"	"	"	"	"	"	"	"	"	90	"	"	25	125	1400	425
RN4 80/400A	200L	30	6	"	"	"	"	"	"	"	"	"	"	"	90	"	"	25	105	1430	460
RN4 100/200C	100L	3	3	125	100	125	470	320	280	1200	205	790	440	400	90	19	30	0	100	960	180
RN4 100/200B	112M	4	3	"	"	"	"	"	"	"	"	"	"	"	90	"	"	0	88	960	180
RN4 100/200A	132S	5.5	3	"	"	"	"	"	"	"	"	"	"	"	90	"	"	0	68	1045	195
RN4 100/250B	132M	7.5	5	125	100	140	470	345	280	1200	205	790	505	465	90	19	30	0	93	1060	225
RN4 100/250A	132M	9.2	5	"	"	"	"	"	"	"	"	"	"	"	90	"	"	0	93	1060	130
RN4 100/315C	160M	11	5	125	100	140	470	370	315	1200	205	790	505	465	90	19	30	0	90	1215	280
RN4 100/315B	160L	15	5	"	"	"	"	"	"	"	"	"	"	"	90	"	"	0	90	1260	300
RN4 100/315A	180M	18.5	5	"	"	"	"	"	"	"	"	"	"	"	90	"	"	0	70	1295	330
RN4100/400C	180L	22	6	125	100	140	530	445	355	1300	215	870	540	460	110	24	13	25	125	1375	410
RN4100/400B	200L	30	6	"	"	"	"	"	"	"	"	"	"	"	110	"	"	25	105	1450	450
RN4100/400A	225S	37	6	"	"	"	"	"	"	"	"	"	"	"	110	"	"	25	80	1540	485
RN4125/250E	132S	5.5	5	150	125	140	470	370	355	1200	205	790	505	465	90	19	30	0	118	1060	235
RN4125/250D	132M	7.5	5	"	"	"	"	"	"	"	"	"	"	"	90	"	"	0	118	1060	240
RN4125/250C	132M	9.2	5	"	"	"	"	"	"	"	"	"	"	"	90	"	"	0	118	1060	250
RN4125/250B	160M	11	5	"	"	"	"	"	"	"	"	"	"	"	90	"	"	0	90	1215	270
RN4125/250A	160L	15	5	"	"	"	"	"	"	"	"	"	"	"	90	"	"	0	90	1260	285
RN4125/315C	180M	18.5	6	150	125	140	530	445	355	1300	215	870	510	460	110	24	13	25	125	1390	365
RN4125/315B	180L	22	6	"	"	"	"	"	"	"	"	"	"	"	110	"	"	25	125	1460	390
RN4125/315A	200L	30	6	"	"	"	"	"	"	"	"	"	"	"	110	"	"	25	105	1460	415
RN4 125/315A	225S	37	6	"	"	"	"	"	"	"	"	"	"	"	110	"	"	25	80	1570	475
RN4 125/400C	225S	37	6	150	125	140	530	480	400	1300	215	870	510	460	110	24	13	25	115	1570	510
RN4125/400B	225M	45	6	"	"	"	"	"	"	"	"	"	"	"	110	"	"	25	115	1570	535
RN4125/400A	250M	55	7	"	"	"	"	"	"	1450	235	980	560	510	110	"	"	25	90	1570	575
RN4125/400A	280S	75	7	"	"	"	"	"	"	"	"	"	"	"	110	"	"	25	60	1700	675
RN4150/315D	180M	18.5	7	200	150	160	530	445	400	1450	235	980	560	510	110	24	13	25	125	1410	385
RN4150/315C	180L	22	7	"	"	"	"	"	"	"	"	"	"	"	110	"	"	25	125	1490	410
RN4 150/315B	200L	30	7	"	"	"	"	"	"	"	"	"	"	"	110	"	"	25	105	1490	435
RN4 150/315A	225S	37	7	"	"	"	"	"	"	"	"	"	"	"	110	"	"	25	80	1590	495
RN4 150/315A	225M	45	7	"	"	"	"	"	"	"	"	"	"	"	110	"	"	25	80	1590	520
RN4 150/400C	225S	37	7	200	150	160	530	480	450	1450	235	980	560	510	110	24	13	25	115	1590	570
RN4 150/400C	225M	45	7	"	"	"	"	"	"	"	"	"	"	"	110	"	"	25	115	1590	570
RN4 150/400B	250M	55	7	"	"	"	"	"	"	"	"	"	"	"	110	"	"	25	90	1590	605
RN4 150/400A	280S	75	7	"	"	"	"	"	"	"	"	"	"	"	110	"	"	25	60	1720	705
RN4 150/400A	280M	90	7	"	"	"	"	"	"	"	"	"	"	"	110	"	"	25	60	1720	775

Pompa tipo Pump size	Motore - Motor		Base Base- Plate n.°	DIMENSIONI - DIMENSIONS [mm]																	Peso (a) Weight [kg]
	Grand. Size	KW		DNa	DNm	a	f	h3	h2	L1	L2	L3	B2	B3	w	d	b	c1	c2	T ^(a)	
RN4 32/125F	71	0.25	1	50	32	80	360	172	140	750	120	510	350	320	60	14	30	0	41	785	55
RN4 32/125D	71	0.25	1	"	"	"	"	"	"	"	"	"	"	"	60	"	"	0	41	785	55
RN4 32/125A	71	0.25	1	"	"	"	"	"	"	"	"	"	"	"	60	"	"	0	41	785	55
RN4 32/160B	71	0.37	1	50	32	80	360	192	160	750	120	510	350	320	60	14	30	0	61	785	65
RN4 32/160A	71	0.37	1	"	"	"	"	"	"	"	"	"	"	"	60	"	"	0	61	785	65
RN4 32/200B	80	0.55	1	50	32	80	360	220	180	750	120	510	350	320	60	14	30	0	80	815	75
RN4 32/200A	80	0.75	1	"	"	"	"	"	"	"	"	"	"	"	60	"	"	0	80	815	75
RN4 40/125F	71	0.25	1	65	40	80	360	172	140	750	120	510	350	320	60	14	30	0	41	785	60
RN4 40/125C	71	0.37	1	"	"	"	"	"	"	"	"	"	"	"	60	"	"	0	41	785	60
RN4 40/125A	71	0.37	1	"	"	"	"	"	"	"	"	"	"	"	60	"	"	0	41	785	60
RN4 40/160C	71	0.37	1	65	40	80	360	192	160	750	120	510	350	320	60	14	30	0	41	785	65
RN4 40/160B	80	0.55	1	"	"	"	"	"	"	"	"	"	"	"	60	"	"	0	52	815	70
RN4 40/160A	80	0.75	1	"	"	"	"	"	"	"	"	"	"	"	60	"	"	0	52	815	70
RN4 40/200B	90S	1.1	2	65	40	100	360	280	180	1000	170	660	400	360	60	19	30	0	70	860	80
RN4 40/200A	90S	1.1	2	"	"	"	"	"	"	"	"	"	"	"	60	"	"	0	70	860	80
RN4 40/250C	90L	1.5	2	65	40	100	360	300	225	1000	170	660	400	360	75	19	30	0	90	885	125
RN4 40/250B	100L	2.2	2	"	"	"	"	"	"	"	"	"	"	"	75	"	"	0	80	925	150
RN4 40/250A	100L	3	2	"	"	"	"	"	"	"	"	"	"	"	75	"	"	0	80	925	150
RN4 50/125F	71	0.37	1	65	50	100	360	192	160	750	120	510	350	320	60	14	30	0	61	805	70
RN4 50/125D	80	0.55	1	"	"	"	"	"	"	"	"	"	"	"	60	"	"	0	52	835	70
RN4 50/125A	80	0.75	1	"	"	"	"	"	"	"	"	"	"	"	60	"	"	0	52	835	75
RN4 50/125S	80	0.75	1	"	"	"	"	"	"	"	"	"	"	"	60	"	"	0	52	835	75
RNA 50/160B	90S	1.1	2	65	50	100	360	280	180	1000	170	660	400	360	60	14	30	0	70	860	80
RN4 50/160A	90S	1.1	2	"	"	"	"	"	"	"	"	"	"	"	60	"	"	0	70	860	80
RN4 50/200C	90S	1.1	2	65	50	100	360	280	200	1000	170	660	400	360	60	19	30	0	70	860	85
RN4 50/200B	90L	1.5	2	"	"	"	"	"	"	"	"	"	"	"	60	"	"	0	70	885	90
RN4 50/200A	100L	2.2	2	"	"	"	"	"	"	"	"	"	"	"	75	"	"	0	60	925	95
RN4 50/250C	100L	2.2	2	65	50	100	360	300	225	1000	170	660	400	360	75	19	30	0	80	925	150
RN4 50/250B	100L	3	2	"	"	"	"	"	"	"	"	"	"	"	75	"	"	0	80	925	155
RN4 50/250A	112M	4	2	"	"	"	"	"	"	"	"	"	"	"	75	"	"	0	68	925	155
RN4 65/125E	80	0.75	1	80	65	100	360	220	180	750	120	510	350	320	75	19	30	0	80	835	90
RN4 65/125C	80	0.75	1	"	"	"	"	"	"	"	"	"	"	"	75	"	"	0	80	835	90
RN4 65/125A	90S	1.1	2	"	"	"	"	280	"	1000	170	660	400	360	75	"	"	0	70	860	95
RN4 65/160C	90S	1.1	2	80	65	100	360	280	200	1000	170	660	400	360	75	19	30	0	70	860	95
RN4 65/160B	90S	1.1	2	"	"	"	"	"	"	"	"	"	"	"	75	"	"	0	70	860	95
RN4 65/160A	90L	1.5	2	"	"	"	"	"	"	"	"	"	"	"	75	"	"	0	70	885	100
RN4 65/200B	100L	2.2	2	80	65	100	360	300	225	1000	170	660	400	360	75	19	30	0	80	965	125
RN4 65/200A	100L	3	2	"	"	"	"	"	"	"	"	"	"	"	75	"	"	0	80	965	150
RN4 65/250B	112M	4	3	80	65	100	470	320	250	1200	205	790	440	400	90	19	30	0	88	1075	175
RN4 65/250A	132S	5.5	3	"	"	"	"	"	"	"	"	"	"	"	90	"	"	0	68	1160	190
RN4 65/315C	132S	5.5	5	80	65	125	470	345	280	1200	205	790	505	465	90	19	30	0	93	1185	230
RN4 65/315B	132M	7.5	5	"	"	"	"	"	"	"	"	"	"	"	90	"	"	0	93	1185	235
RN4 65/315A	132M	9.2	5	"	"	"	"	"	"	"	"	"	"	"	90	"	"	0	93	1185	240
RN4 80/160C	90S	1.1	2	100	80	125	360	300	225	1000	170	660	400	360	75	19	30	0	90	925	120
RN4 80/160B	90L	1.5	2	"	"	"	"	"	"	"	"	"	"	"	75	"	"	0	90	950	125
RN4 80/160A	100L	2.2	2	"	"	"	"	"	"	"	"	"	"	"	75	"	"	0	80	990	150
RN4 80/200C	100L	2.2	3	100	80	125	470	300	250	1200	205	790	440	400	75	19	30	0	80	1100	165
RN4 80/200B	100L	3	3	"	"	"	"	"	"	"	"	"	"	"	75	"	"	0	80	1100	165
RN4 80/200A	112M	4	3	"	"	"	"	"	"	"	"	"	"	"	75	"	"	0	68	1100	170
RN4 80/250C	112M	4	5	100	80	125	470	320	280	1200	205	790	505	465	90	19	30	0	88	1100	190
RN4 80/250B	132S	5.5	5	"	"	"	"	"	"	"	"	"	"	"	90	"	"	0	68	1185	205
RN4 80/250A	132M	7.5	5	"	"	"	"	"	"	"	"	"	"	"	90	"	"	0	68	1185	215

Pompa tipo Pump size	Motore - Motor		Base Base- Plate n.°	DIMENSIONI - DIMENSIONS [mm]																	Peso ^(a) Weight [kg]
	Grand. Size	KW		DNa	Dnm	a	f	h3	h2	L1	L2	L3	B2	B3	w	d	b	c1	c2	T ^(a)	
RN4 80/315C	132M	9.2	5	100	80	125	470	370	315	1200	205	790	505	465	90	19	30	0	118	1185	240
RN4 80/315B	160M	11	6	"	"	"	"	415	"	1300	215	870	510	460	90	24	13	25	90	1340	270
RN4 80/315A	160L	15	6	"	"	"	"	"	"	"	"	"	"	"	90	"	"	25	90	1385	285
RN4 80/400C	180M	18.5	7	125	80	125	530	445	355	1450	235	980	560	510	90	24	13	25	125	1500	405
RN4 80/400B	180L	22	7	"	"	"	"	"	"	"	"	"	"	"	90	"	"	25	125	1540	425
RN4 80/400A	200L	30	7	"	"	"	"	"	"	"	"	"	"	"	90	"	"	25	105	1570	460
RN4 100/200C	100L	3	3	125	100	125	470	320	280	1200	205	790	440	400	90	19	30	0	100	1100	180
RN4 100/200B	112M	4	3	"	"	"	"	"	"	"	"	"	"	"	90	"	"	0	88	1100	180
RN4 100/200A	132S	5.5	3	"	"	"	"	"	"	"	"	"	"	"	90	"	"	0	68	1185	195
RN4 100/250B	132M	7.5	5	125	100	140	470	345	280	1200	205	790	505	465	90	19	30	0	93	1200	225
RN4 100/250A	132M	9.2	5	"	"	"	"	"	"	"	"	"	"	"	90	"	"	0	93	1200	150
RN4 100/315C	160M	11	6	125	100	140	470	415	315	1300	215	870	515	460	90	24	13	25	90	1355	280
RN4 100/315B	160L	15	6	"	"	"	"	"	"	"	"	"	"	"	90	"	"	25	90	1400	300
RN4 100/315A	180M	18.5	6	"	"	"	"	"	"	"	"	"	"	"	90	"	"	25	70	1435	330
RN4100/400C	180L	22	7	125	100	140	530	445	355	1450	235	980	560	510	110	24	13	25	125	1515	410
RN4100/400B	200L	30	7	"	"	"	"	"	"	"	"	"	"	"	110	"	"	25	105	1590	450
RN4100/400A	225S	37	7	"	"	"	"	"	"	"	"	"	"	"	110	"	"	25	80	1680	485
RN4125/250E	132S	5.5	5	150	125	140	470	370	355	1200	205	790	505	465	90	19	30	0	118	1200	235
RN4125/250D	132M	7.5	5	"	"	"	"	"	"	"	"	"	"	"	90	"	"	0	118	1200	240
RN4125/250C	132M	9.2	5	"	"	"	"	"	"	"	"	"	"	"	90	"	"	0	118	1200	250
RN4125/250B	160M	11	6	"	"	"	"	415	"	1300	215	870	510	460	90	24	13	25	90	1355	270
RN4125/250A	160L	15	6	"	"	"	"	"	"	"	"	"	"	"	90	"	"	25	90	1400	285
RN4125/315C	180M	18.5	7	150	125	140	530	445	355	1450	235	980	560	510	110	24	13	25	125	1530	365
RN4125/315B	180L	22	7	"	"	"	"	"	"	"	"	"	"	"	110	"	"	25	125	1600	390
RN4125/315A	200L	30	7	"	"	"	"	"	"	"	"	"	"	"	110	"	"	25	105	1600	415
RN4 125/315A	225S	37	7	"	"	"	"	"	"	"	"	"	"	"	110	"	"	25	80	1710	475
RN4 125/400C	225S	37	7	150	125	140	530	480	400	1450	235	870	510	460	110	24	13	25	115	1710	510
RN4125/400B	225M	45	7	"	"	"	"	"	"	"	"	"	"	"	110	"	"	25	115	1710	535
RN4125/400A	250M	55	8	"	"	"	"	"	"	1590	"	1120	"	"	110	"	"	25	90	1710	575
RN4125/400A	280S	75	8	"	"	"	"	"	"	"	"	"	"	"	110	"	"	25	60	1840	675
RN4150/315D	180M	18.5	7	200	150	160	530	445	400	1450	235	980	560	510	110	24	13	25	125	1550	385
RN4150/315C	180L	22	7	"	"	"	"	"	"	"	"	"	"	"	110	"	"	25	125	1630	410
RN4 150/315B	200L	30	7	"	"	"	"	"	"	"	"	"	"	"	110	"	"	25	105	1630	435
RN4 150/315A	225S	37	7	"	"	"	"	"	"	"	"	"	"	"	110	"	"	25	80	1730	495
RN4 150/315A	225M	45	7	"	"	"	"	"	"	"	"	"	"	"	110	"	"	25	80	1730	520
RN4 150/400C	225S	37	7	200	150	160	530	480	450	1450	235	980	560	510	110	24	13	25	115	1730	570
RN4 150/400C	225M	45	7	"	"	"	"	"	"	"	"	"	"	"	110	"	"	25	115	1730	570
RN4 150/400B	250M	55	8	"	"	"	"	"	"	1590	"	1120	"	"	110	"	"	25	90	1730	605
RN4 150/400A	280S	75	8	"	"	"	"	"	"	"	"	"	"	"	110	"	"	25	60	1860	705
RN4 150/400A	280M	90	8	"	"	"	"	"	"	"	"	"	"	"	110	"	"	25	60	1860	775

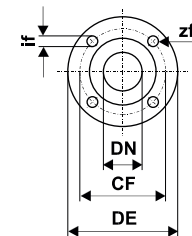
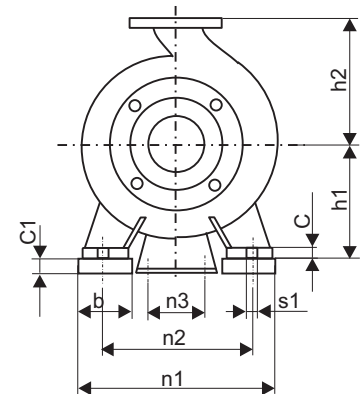
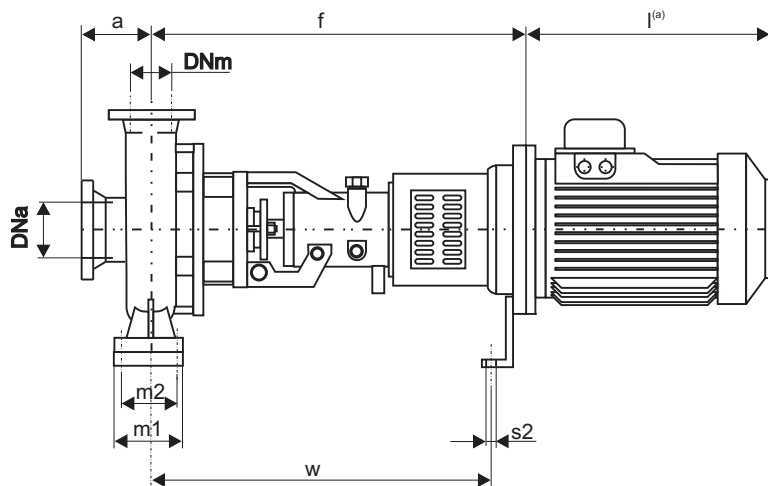
MOTORE ELETTRICO - ELECTRIC MOTOR

Grandezza Size IEC	Potenza in [kW] Power in [kW]			L ^(a) [mm]	Peso Weight ^(a) [kg]
	2 Poli 2 Poles	4 Poli 4 Poles	6 Poli 6 Poles		
	80	0.75	0.55		
80	1.1	0.75	0.55	232	10
90	1.5	1.1	0.75	270	13
90	2.2	1.5	1.1	270	16
100	3	2.2	1.5	298	21
100	-	3	-	298	23
112	4	4	2.2	312	30
132	5.5	5.5	3	381	40
132	7.5	7.5	4	381	50
132	9.2	9.2	5.5	381	50
160	11	11	7.5	486	76
160	15	15	11	486	85
160	18.5	-	-	486	95
180	22	18.5	15	576	130
180	-	22	-	576	145

Dimensioni Flange - Dimensions Flanges EN 1092-2 PN 10

DNa - DNm	32	40	50	65	80	100	125
CF	100	110	125	145	160	180	210
DE	140	150	165	185	200	220	250
if	19	19	19	19	19	19	19
zf	4	4	4	4	8	8	8

Pompa tipo Pump size	Motore Grand.	DIMENSIONI - DIMENSIONS [mm]															Peso ^(b) Weight [kg]		
		DNa	DNm	a	f	h1	h2	b	m1	m2	n1	n2	n3	w	c	c1		s1	s2
32-125	80	50	32	80	422	112	140	50	100	70	190	140	110	379	14	-	14	14	48
	90	"	"	"	422	"	"	"	"	"	"	"	"	"	"	-	"	"	52
	100	"	"	"	447	"	"	"	"	"	"	"	"	"	"	25	"	"	62
32-160	80	50	32	80	442	132	160	50	100	70	240	190	110	379	14	-	14	14	55
	90	"	"	"	422	"	"	"	"	"	"	"	"	"	"	-	"	"	62
	100	"	"	"	447	"	"	"	"	"	"	"	"	"	"	-	"	"	73
	112	"	"	"	447	"	"	"	"	"	"	"	"	"	"	-	"	"	80
32-200	80	50	32	80	422	160	180	50	100	70	240	190	110	379	14	-	14	14	62
	90	"	"	"	422	"	"	"	"	"	"	"	"	"	"	"	"	"	66
	100	"	"	"	447	"	"	"	"	"	"	"	"	"	"	"	"	"	80
	112	"	"	"	447	"	"	"	"	"	"	"	"	"	"	"	"	"	87
	132	"	"	"	467	"	"	"	"	"	"	"	190	419	"	25	"	"	109
40-125	80	65	40	80	422	112	140	50	100	70	210	160	110	379	14	-	14	14	51
	90	"	"	"	422	"	"	"	"	"	"	"	"	"	"	"	"	"	55
	100	"	"	"	447	"	"	"	"	"	"	"	"	"	"	25	"	"	69
40-160	80	65	40	80	422	132	160	50	100	70	240	190	110	379	14	-	14	14	57
	90	"	"	"	422	"	"	"	"	"	"	"	"	"	"	"	"	"	61
	100	"	"	"	447	"	"	"	"	"	"	"	"	"	"	"	"	"	75
	112	"	"	"	447	"	"	"	"	"	"	"	"	"	"	"	"	"	82
	132	"	"	"	467	"	"	"	"	"	"	"	190	419	"	25	"	"	104

 Quote e pesi suscettibili di variazione.
 Dimensions and weights are subject to variations.

^(a)Quota indicativa può variare in funzione della marca del motore
 Not binding dimension that can change according to motor brand

^(b)Peso senza motore elettrico
 Weight without electric motor



**SALVATORE
ROBUSCHI
POMPE PARMA**

INGOMBRI LANTERNATA

**LANTERN BRACKET PUMP
OVERALL DIMENSIONS**

RNL

N : T-1375

DATA: 17.10.2011

Pompa tipo Pump size	Motore Grand.	DIMENSIONI - DIMENSIONS [mm]																	Peso ^(b) Weight [kg]
		DNa	DNm	a	f	h1	h2	b	m1	m2	n1	n2	n3	w	c	c1	s1	s2	
40-200	90	65	40	100	422	160	180	50	100	70	265	212	110	379	14	-	14	14	70
	100	"	"	"	447	"	"	"	"	"	"	"	"	"	"	"	"	"	84
	112	"	"	"	447	"	"	"	"	"	"	"	"	"	"	"	"	"	91
	132	"	"	"	467	"	"	"	"	"	"	"	190	419	"	"	"	"	113
40-250	90	65	40	100	422	180	225	65	125	95	320	250	110	379	14	-	14	14	83
	100	"	"	"	447	"	"	"	"	"	"	"	"	"	"	"	"	"	97
	112	"	"	"	447	"	"	"	"	"	"	"	"	"	"	"	"	"	104
	132	"	"	"	467	"	"	"	"	"	"	"	190	419	"	"	"	"	126
50-125	80	65	50	100	422	132	160	50	100	70	240	190	110	379	14	-	14	14	61
	90	"	"	"	447	"	"	"	"	"	"	"	"	"	"	"	"	"	69
	100	"	"	"	447	"	"	"	"	"	"	"	"	"	"	"	"	"	79
	112	"	"	"	467	"	"	"	"	"	"	"	"	"	"	"	"	"	86
50-160	90	65	50	100	422	160	180	50	100	70	265	212	110	379	14	-	14	14	67
	100	"	"	"	447	"	"	"	"	"	"	"	"	"	"	"	"	"	81
	112	"	"	"	447	"	"	"	"	"	"	"	"	"	"	"	"	"	88
	132	"	"	"	467	"	"	"	"	"	"	"	190	419	"	"	"	"	110
50-200	90	65	50	100	422	160	200	50	100	70	265	212	110	379	14	-	14	14	73
	100	"	"	"	447	"	"	"	"	"	"	"	"	"	"	"	"	"	87
	112	"	"	"	447	"	"	"	"	"	"	"	"	"	"	"	"	"	94
	132	"	"	"	467	"	"	"	"	"	"	"	190	419	"	"	"	"	116
50-250	100	50	65	100	447	180	225	65	125	95	320	250	110	379	16	-	14	14	99
	112	"	"	"	447	"	"	"	"	"	"	"	"	379	"	"	"	"	106
	132	"	"	"	467	"	"	"	"	"	"	"	190	419	"	"	"	"	126
	65-125	80	80	65	100	422	160	180	65	125	95	280	212	110	379	15	-	14	14
90		"	"	"	422	"	"	"	"	"	"	"	"	379	"	"	"	"	73
100		"	"	"	447	"	"	"	"	"	"	"	"	379	"	"	"	"	87
112		"	"	"	447	"	"	"	"	"	"	"	"	379	"	"	"	"	94
132		"	"	"	467	"	"	"	"	"	"	"	190	419	"	"	"	"	114
65-160	80	80	65	100	422	160	200	65	125	95	280	212	110	379	15	-	14	14	70
	90	"	"	"	422	"	"	"	"	"	"	"	"	379	"	"	"	"	74
	100	"	"	"	447	"	"	"	"	"	"	"	"	379	"	"	"	"	88
	112	"	"	"	447	"	"	"	"	"	"	"	"	379	"	"	"	"	95
	132	"	"	"	467	"	"	"	"	"	"	"	190	419	"	"	"	"	115
65-200	90	80	65	100	422	180	225	65	125	95	320	250	110	379	16	-	14	14	81
	100	"	"	"	447	"	"	"	"	"	"	"	"	379	"	"	"	"	95
	112	"	"	"	447	"	"	"	"	"	"	"	"	379	"	"	"	"	102
	132	"	"	"	467	"	"	"	"	"	"	"	190	419	"	"	"	"	122
65-250	100	80	65	100	545	200	250	80	160	120	360	280	110	500	18	-	18	14	130
	112	"	"	"	545	"	"	"	"	"	"	"	"	500	"	"	"	"	137
	132	"	"	"	565	"	"	"	"	"	"	"	190	520	"	"	"	"	161
65-315	132	80	65	125	565	225	280	80	160	120	400	315	190	520	18	-	18	14	202
80-160	90	100	80	125	422	180	225	65	125	95	320	250	110	379	15	-	14	14	84
	100	"	"	"	447	"	"	"	"	"	"	"	"	379	"	"	"	"	98
	112	"	"	"	447	"	"	"	"	"	"	"	"	379	"	"	"	"	105
	132	"	"	"	467	"	"	"	"	"	"	"	190	419	"	"	"	"	129
80-200	100	100	80	125	545	180	250	65	125	95	345	280	110	500	16	-	14	14	125
	112	"	"	"	545	"	"	"	"	"	"	"	"	500	"	"	"	"	132
	132	"	"	"	565	"	"	"	"	"	"	"	190	520	"	"	"	"	156
80-250	112	100	80	125	545	200	280	80	160	120	400	315	110	500	18	-	18	14	153
	132	"	"	"	565	"	"	"	"	"	"	"	190	520	"	"	"	"	177
100-200	100	125	100	125	545	200	280	80	160	120	360	280	110	500	16	-	18	14	136
	112	"	"	"	545	"	"	"	"	"	"	"	"	500	"	"	"	"	143
	132	"	"	"	565	"	"	"	"	"	"	"	190	520	"	"	"	"	167
100-250	132	125	100	140	565	225	280	80	160	120	400	325	190	520	18	-	18	14	187

Quote e pesi suscettibili di variazione.
Dimensions and weights are subject to variations.

^(b)Peso senza motore elettrico
Weight without electric motor

^(a)Quota indicativa può variare in funzione della marca del motore
Not binding dimension that can change according to motor brand

