

Table of Contents

Product Overview.....	3	Dimensions for 5LE & 4108	
LE Standard.....	3	Close Coupled to a 56 Frame 1 Phase Motor.....	22
LE Metric.....	3	Dimensions for 5LE & 4108	
00, 0, 1, & 2LE Pump Mounting Dimensions.....	5	Close Coupled to a 56 Frame 3 Phase Motor.....	23
5LE Pump Mounting Dimensions.....	6	Dimensions for 30LE-2LE & 4101-4105 Adapter Mounted to a 56 Frame Single & 3 Phase Motor.....	24
LSA Pump Mounting Dimensions.....	7	Dimensions for 30LE-2LE & 4101-4105 Adapter Mounted to a 143/145TC Frame Single & 3 Phase Motor.....	25
L Pump Model Number System.....	8	Dimensions for 5LE & 4108 Adapter Mounted to a 56 Frame 1 & 3 Phase Motor.....	26
LE Pump Temperature Limits.....	9	Dimensions for 5LE, 4108 & 4128 Adapter Mounted to a 143/145TC Frame 1 & 3 Phase Motor.....	27
Materials of Construction.....	9	Dimensions for LE Series Mounting Foot (0L81-C).....	28
4100/LE Cross Reference List.....	10	1R1F-A Pump Mounting Dimensions.....	28
4100/LE Cross Reference List (Continued).....	11	00LFD, 0LFD, 1LFD, 00RFD, 0RFD, & 1RFD Pump Mounting Dimensions.....	29
4120/LE Cross Reference List.....	11	2LFD & 2RFD Pump Mounting Dimensions.....	30
4101 Pump Mounting Dimensions.....	12	Cartridge Pump Model Number System.....	31
4102-4105 Pump Mounting Dimensions.....	13	Cartridge Pump Materials of Construction.....	31
4108 Pump Mounting Dimensions.....	14	Model Number Locations.....	32
4100 Pump Model Number System.....	15		
4100 Pump Temperature Limits.....	16		
4100 Pump Materials of Construction.....	16		
L/4100/Cartridge Pump NPSH Data.....	17		
Viscosity Correction Factor.....	17		
Dimensions for 30LE-2LE & 4101-4105			
Close Coupled to a 48 Frame 1 Phase Motor.....	18		
Dimensions for 30LE-2LE & 4101-4105			
Close Coupled to a 56 Frame 1 Phase Motor.....	19		
Dimensions for 30LE-2LE & 4101-4105			
Close Coupled to a 48 Frame 3 Phase Motor.....	20		
Dimensions for 30LE-2LE & 4101-4105			
Close Coupled to a 56 Frame 3 Phase Motor.....	21		

Product Overview

- Positive Displacement
- Internal Rotary Gear Design
- Cast Iron Construction
- NPT Top Ports
- Mechanical Seal (Viton)
- Six Sizes - 1/2 to 14 GPH
- Typical Viscosity Range - 40 to 1000 SSU
- Temperature to 375°F
- Inlet Pressure to 250 PSI
- Standard Discharge Pressure to 300 PSI

Overview Options

- Seal Elastomer - Neoprene or EPR
- Internal Relief Valve
- High Pressure Modification to 500 PSI Discharge
- Outboard Ball Bearing for Indirect Drive
- Reversing Feature
- SAE Porting
- Mounting Fast for Base Mount Direct Drive
- Adaptor Kit for NEMA C Face Mounting
- Shaft Modification for Close Coupled Mounting
- Stripped Version (LSA) Consists of Cover, Idler Gear, and Rotor Assembly for OEM Built-In Applications

LE Standard

- MOC - Cast Iron
- Mechanical Seal
- 6 Sizes - 0.5 to 14 GPM Nominal
- Viscosity Range - 35 to 1000 SSU
- Temperature to 375 °F
- Pressure - 280 PSI Inlet 500 PSI Discharge
- Differential Pressure - 300
- 5LE - 130 Inlet 300 Discharge
- #2 Fuel Oil is Limited to 100 PSI Max

LE Metric

- MOC - Cast Iron
- Mechanical Seal
- 6 Sizes - 1.9 to 53 LPM Nominal
- Viscosity Range - 35 to 1000 SSU
- Temperature to 375 °F
- Pressure - 19.3 BAR Inlet 34.5 BAR Discharge
- Differential Pressure - 20.7 BAR
- 5LE - 9 BAR Inlet 20.7 BAR Discharge
- #2 Fuel Oil is Limited to 6.9 BAR Max

30LE Pump Mounting Dimensions

PORT TYPES 3/8" - 18 NPT / STD

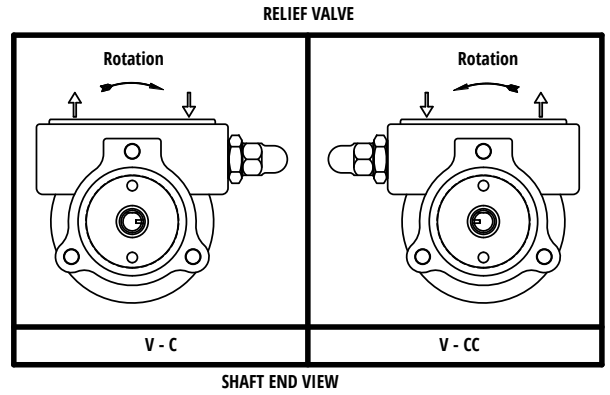
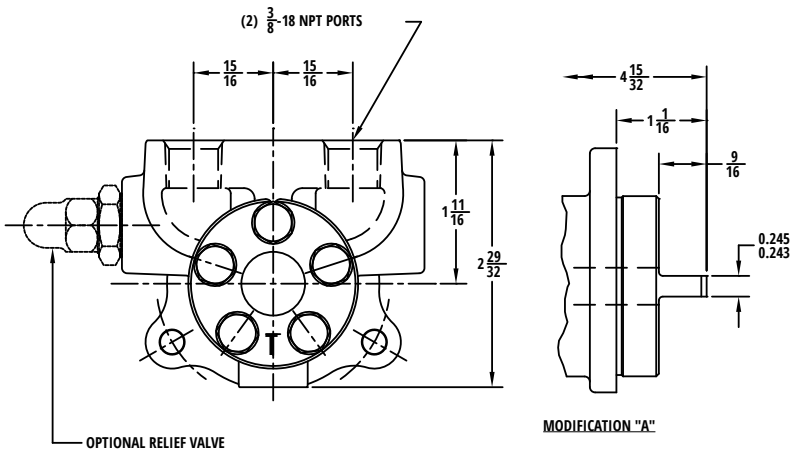
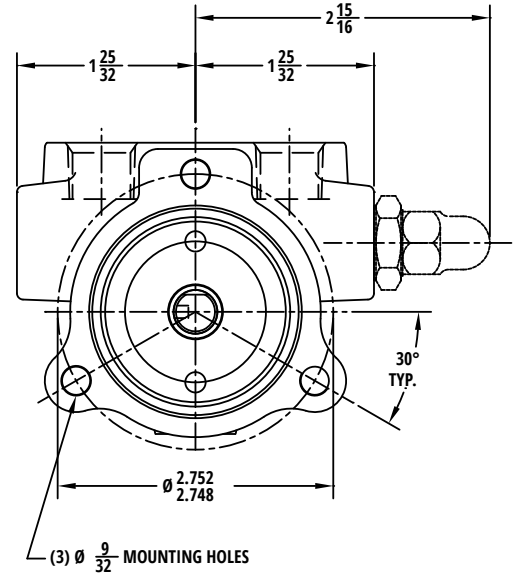
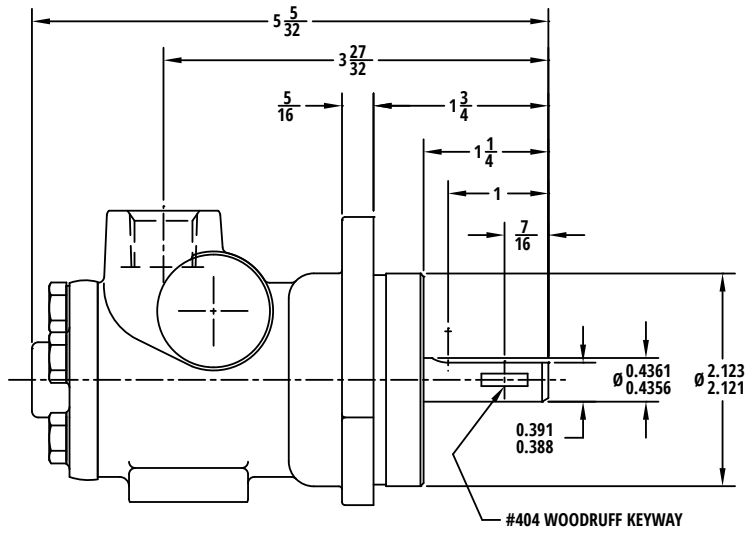

00, 0, 1, & 2LE Pump Mounting Dimensions

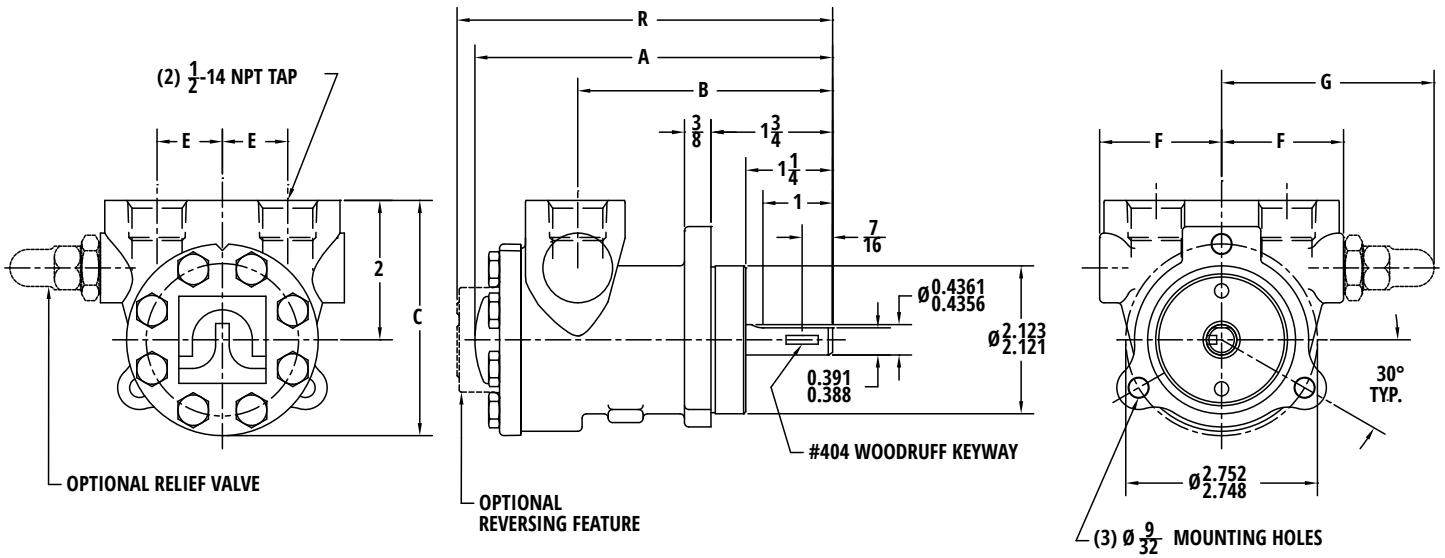

Pump Model		Overall Length		B	C	E	F	G
Bi-Rotational	Reversing	Bi-Rot. (A)	Rev. (R)					
00LE	00RLE	4 15/16	5 3/16	3 15/32	3 15/32	15/16	1 29/32	3 3/32
0LE	0RLE	4 15/16	5 3/16	3 15/32	3 15/32	15/16	1 29/32	3 3/32
1LE	-	5 3/32	-	3 5/8	3 5/16	15/16	1 3/4	3 1/8
-	1RLE	-	5 1/4	3 17/32	3 5/16	15/16	1 3/4	3 1/8
2LE	2RLE	5 15/16	6 1/16	4 7/16	3 5/8	15/16	1 7/8	3 1/8

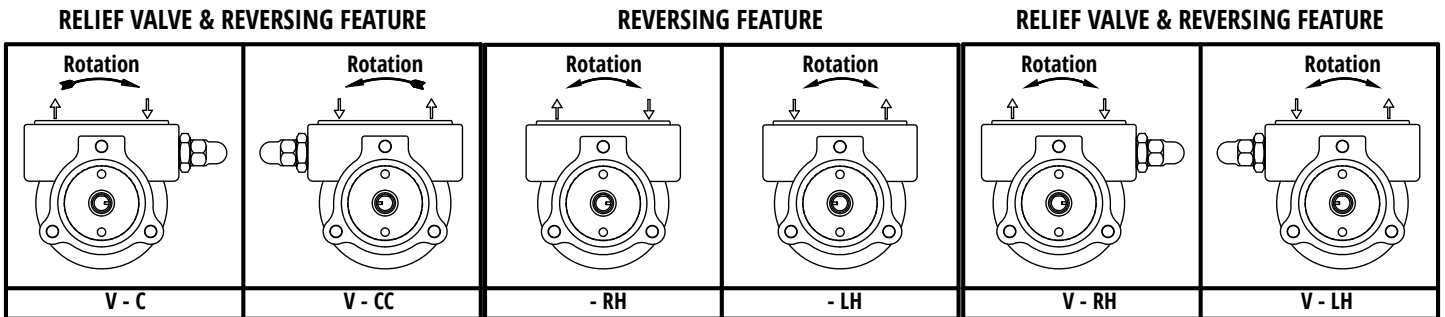

SHAFT END VIEW

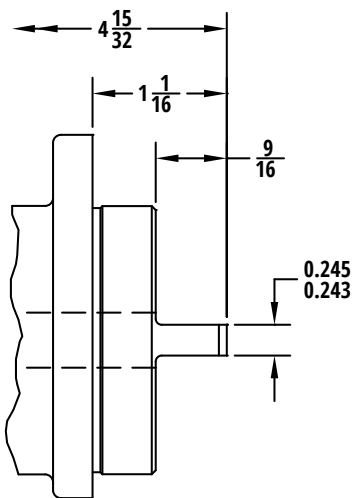

Port Size	Pump Model			
	00LE	0LE	1LE	2LE
1/2" - 14 NPT	STD.	STD.	STD.	STD.
3/4" - 16 UNF (SAE 8)	OPT.	OPT.	OPT.	OPT.

MODIFICATION "A"

5LE Pump Mounting Dimensions

PORT TYPES

1" - 11 1/2 NPT / STD

1 5/16" - 12 UNF (SAE16) Opt.

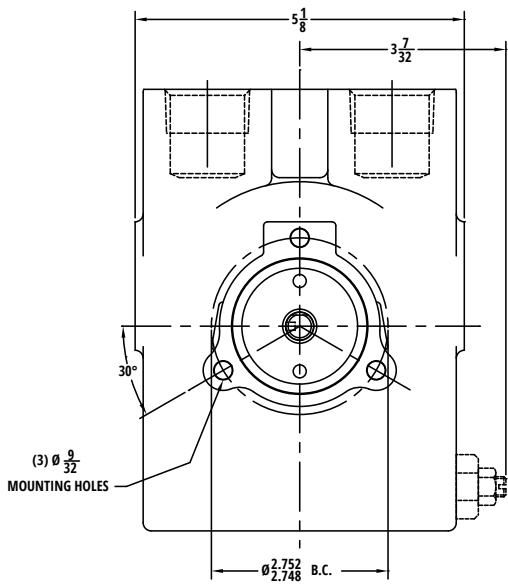
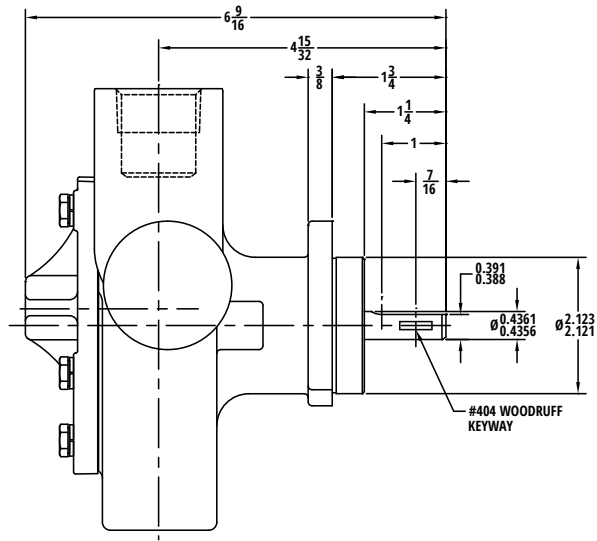
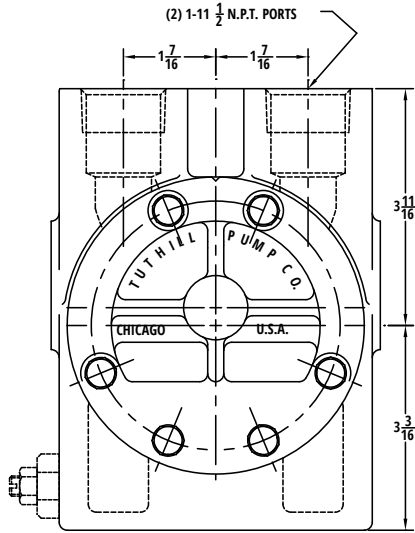

RELIEF VALVE & REVERSING FEATURE

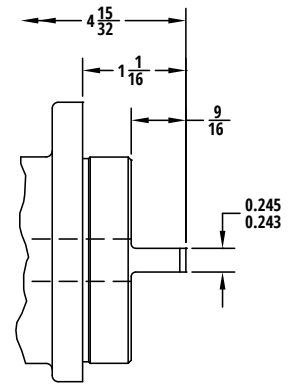
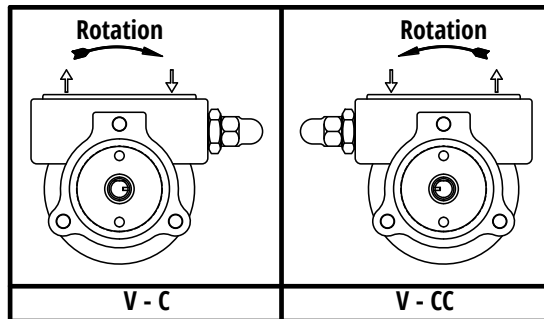

MODIFICATION "A"

LSA Pump Mounting Dimensions

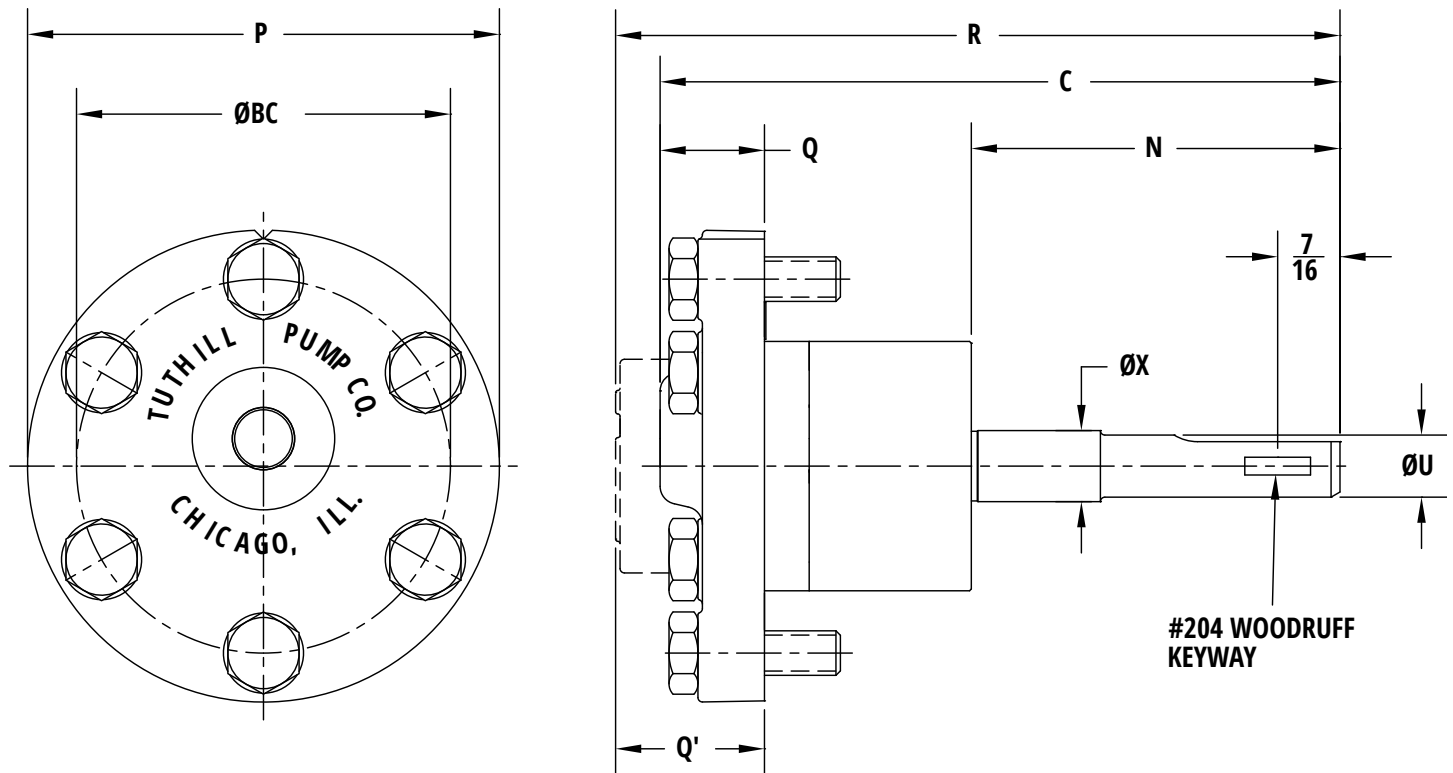

Pump Model		Overall Length		BC	N	P	Q	Q'	U	X
Bi-Rotational	Reversing	Bi-Rot. (C)	Rev. (R)							
	00RLSA	5 3/8	5 5/8	2 3/16	4 1/16	2 3/4	5/8	7/8	<u>.4361</u> .4356	
0LSA	0RLSA	5 3/8	5 5/8	2 3/16	4 1/16	2 3/4	5/8	7/8	<u>.4361</u> .4356	
1LSA	1RLSA	5 3/8	5 5/8	2 3/16	4 1/16	2 3/4	5/8	7/8	<u>.4361</u> .4356	
2LSA	2RLSA	6 3/8	6 1/2	2 5/8	4 3/16	3 5/16	11/16	13/16	<u>.4361</u> .4356	<u>.4992</u> .4987

Note: For information on recommended housing bore and bushing support please call Tuthill Pump Group.

L Pump Model Number System

Position #	Size		Feature	Model			Pump options	Rotation		Modifications	SAE Port Options		
	1	2	3	4	5	6	7	8	9	10	11	12	13

Position #	Description	Codes
1 & 2	Size	-30, -00, -0, -1, -2, or -5
3	Reversing Feature	-R (Not Available for 30 or 5 Size Models)
4, 5, & 6	Model	-LE or -LSA
7	Pump Options	-V = Valve, -K = Outboard Ball Bearing, -U = Cover Rotated 180°, or -H = High Pressure (Not Available on 30LE or 5LE Size)
8 & 9	Rotation (Valved Models)	-C = Clockwise Rotation or -CC = Counterclockwise
	Suction Port Location on Pumps w/ Reversing Feature	-RH = Right Hand Suction or -LH = Left Hand Suction
10	Modifications	-A = Tang Shaft, -5 = Neoprene Seal, -7 = Viton Seal, -8 = EPR Seal, or -N = No Flat/Keyway in Shaft
11, 12, 13, & 14	SAE Port Option	-SAE8 (-NPT is Standard)

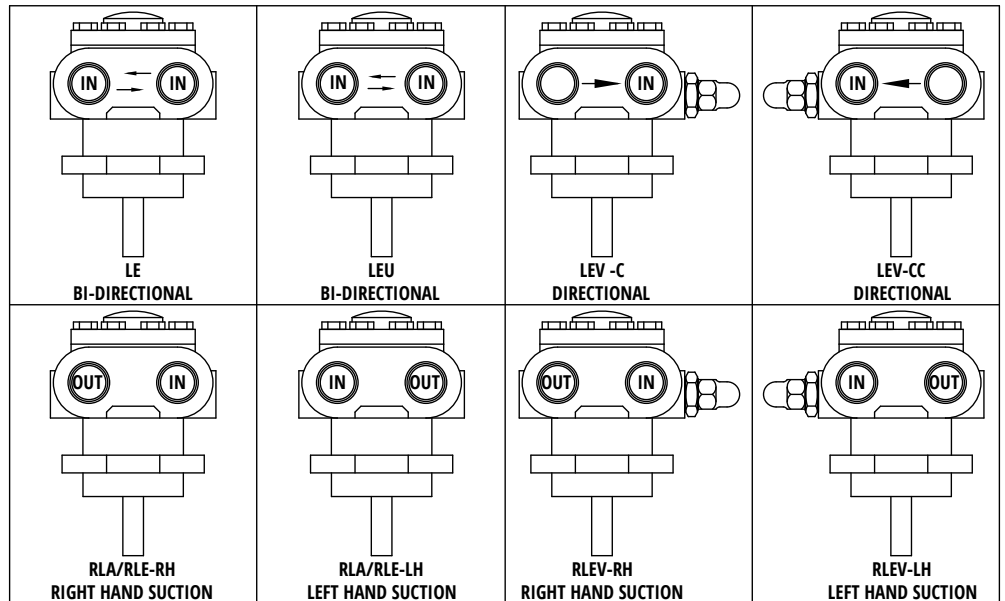
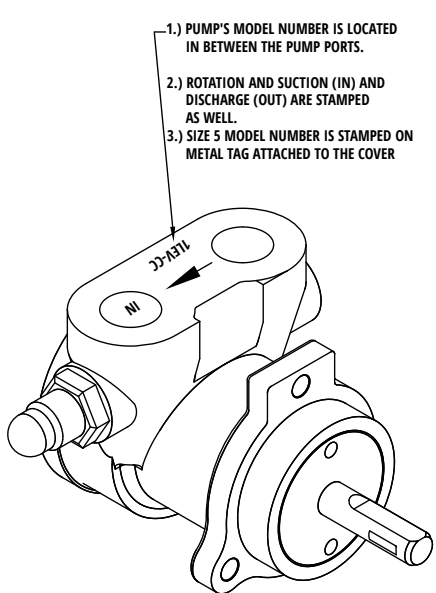

LE Pump Temperature Limits

500 °F					260 °C	
450 °F					232 °C	
400 °F	Bronze Bushing	Carbon Bushings			204 °C	
370 °F					187 °C	
300 °F			Viton		Ethylene Propylene (EPR) Available for 00, 0, & 5LE Sizes Only	149 °C
250 °F						121 °C
200 °F				Neoprene		
150 °F					66 °C	
100 °F					38 °C	
50 °F					10 °C	
0 °F						-18 °C
-10 °F						-23 °C
-40 °F				-40 °C		
-50 °F				-46 °C		
-100 °F				-73 °C		

Note: A pump's performance is dependent on more than just the temperature ranges of the component materials.

Materials of Construction

Part Name	Material	Standard	Comments	Availability
Housing	Cast Iron	ASTM A48 – 96a	Classes 30, 35, or 40	Std.
Housing Bushing	Steel	AISI 12L14		Std.
	Carbon	Carbon Graphite Resin	Std. on 5LE Pumps Only	Opt.
	Bronze	SAE 660	Available on 2L size only	Std.
Cover	Cast Iron	ASTM A48 – 96a	Classes 30, 35, or 40	Std.
Rotor	Steel	ASTM A311	Stressproof	Std.
Idler	P/M Steel	MPIF-0508-P		Std.
	Steel	C1118 or C1117		Opt.
	Plastic	PPS	On 30L size only	Std.
Idler Pin	Steel	C1117	Heat Treated	Std.
Idler Bushing	Bronze	SAE 660		Std.
	Carbon	Carbon Graphite Resin		Opt.
Housing Plug	Steel	AISI 12L14	DU Bushing assembled in housing plug	Std.
Gaskets	Standard	Oriented Polyester		Std.
	Standard	Buna Coated Aluminum	Available on 2L size only	Std.
O-Rings & Seals	Viton			STD
	Neoprene			Opt.
	EPR		Sizes - 00, 0 & 5LE	Opt.

4100/LE Cross Reference List

4000 Series	LE Pump	4100 Series Additional Features
4101	30LE	- Carbon Housing Bushing vs. Cast Iron
		- Steel Idler Gear vs. PPS Plastic
4101K	30LEK	- Same as Above
Options: The -A-V-5-7 and 0L81-C are available on both pumps.		
Note: The Tuthill reversing feature is not available on either pump size.		
4102	00LE	- Hardened Steel Idler Gear vs. Powdered Metal
		- Carbon Idler Bushing vs. None
		- Carbon Housing Bushing vs. Steel
4102K	00LEK	- Same as Above
4102	00LEH	- Carbon Housing Bushing vs. Steel
4102K	00LET	- Carbon Housing Bushing vs. Steel
Options: -R-A-V-5-7-8 and 0L81-C are available on both pumps.		
4103	0LE	- Hardened Steel Idler Gear vs. Powdered Metal
		- Carbon Idler Bushing vs. None
		- Carbon Housing Bushing vs. Steel
4103K	0LEK	- Same As Above
4103	0LEH	- Carbon Idler Bushing vs. None
		- Carbon Housing Bushing vs. Steel
4103K	0LET	- Carbon Idler Bushing vs. None
		- Carbon Housing Bushing vs. Steel
Options: The -R-A-V-5-7-8 and 0L81-C are available on both pumps.		
4104	1LE	- Hardened Steel Idler Gear vs. Powdered Metal
		- Carbon Idler Bushing vs. None
		- Carbon Housing Bushing vs. Steel
4104K	1LEK	- Same as Above
4104	1LEH	- Carbon Idler Bushing vs. None
		- Carbon Housing Bushing vs. Steel
4104K	1LET	- Carbon Idler Bushing vs. None
		- Carbon Housing Bushing vs. Steel
Options: The -R-A-V-5-7-8 and 0L81-C are available on both pumps.		

4100/LE Cross Reference List (Continued)

4000 Series	LE Pump	4100 Series Additional Features
4105	2LE	- Hardened Steel Idler Gear vs. Powdered Metal
		- Carbon Idler Bushing vs. None
		- Carbon Housing Bushing vs. Bronze
4105K	2LEK	- Same as Above
4105	2LEH	- Carbon Idler Bushing vs. None
		- Carbon Housing Bushing vs. Bronze
4105K	2LET	- Carbon Idler Bushing vs. None
		- Carbon Housing Bushing vs. Bronze
Options: The -R-A-V-5-7 and 0L81-C are available on both pumps.		
4108	5LE	- Hardened Steel Idler Gear vs. Powdered Metal
		- Carbon Idler Bushing
4108K	5LEK	- Same as Above
Options: The -A-V-5-7-8 and 0L81-C are available on both pumps.		
Note: The Tuthill reversing feature is not available on either pump size.		

4120/LE Cross Reference List

4120 Series	LE Pump	4120 Series Additional Features
4121-7	30LE	- Ceramic Housing Bushing vs. Cast Iron
		- Steel Idler Gear vs. PPS Plastic
		- Tutrided Cast Iron Cover vs. Cast Iron Cover
		- Induction Hardened Steel Rotor vs. Steel Rotor
		- Abrasion Resistant Mechanical Seal vs. Standard Mechanical Seal
		(Silicon Carbide/Ceramic vs. Carbon/Ceramic)
4122	00LE	- Ceramic Housing Bushing vs. Cast Iron
		- Hardened Steel Idler Gear vs. Powdered Metal
		- Carbon Idler Bushing vs. Bronze
		- Tutrided Cast Iron Cover vs. Cast Iron Cover
		- Induction Hardened Steel Rotor vs. Steel Rotor
		- Abrasion Resistant Mechanical Seal vs. Standard Mechanical Seal
		(Silicon Carbide/Ceramic vs. Carbon/Ceramic)
4123, 4124, & 4125	0LE, 1LE, & 2LE	- Same as Above
4128	5LE	- Same as Above Except Ceramic Housing Bushing vs. Carbon

4101 Pump Mounting Dimensions

PORT TYPES

3/8" - 18 NPT / STD

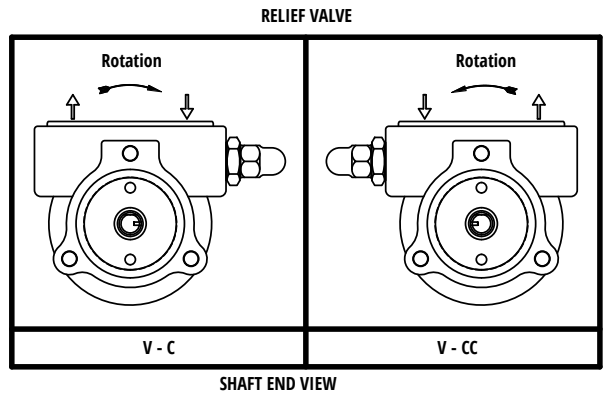
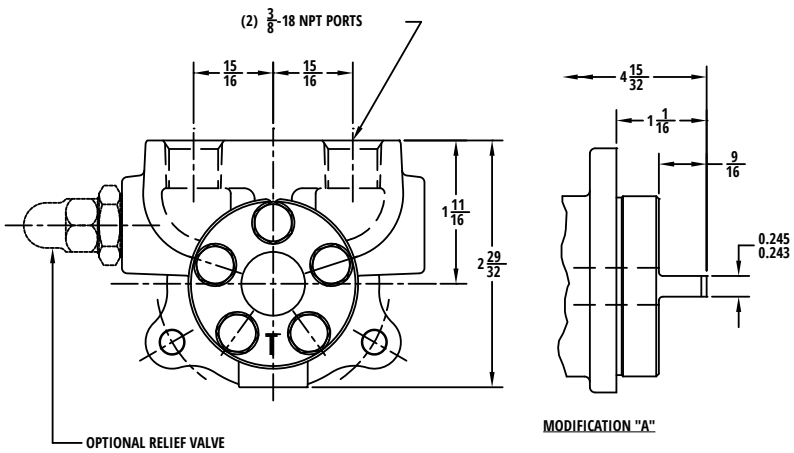
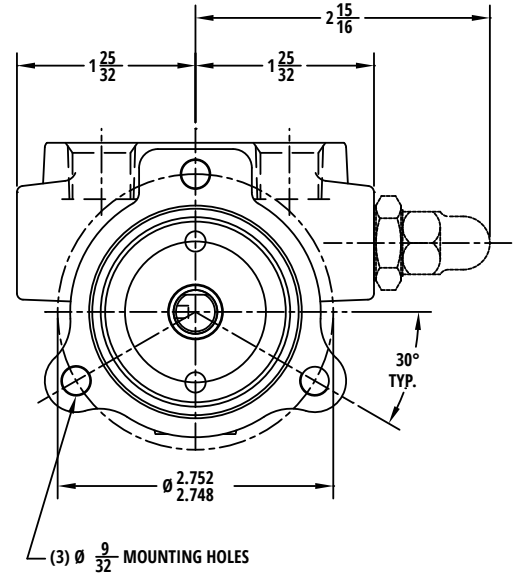
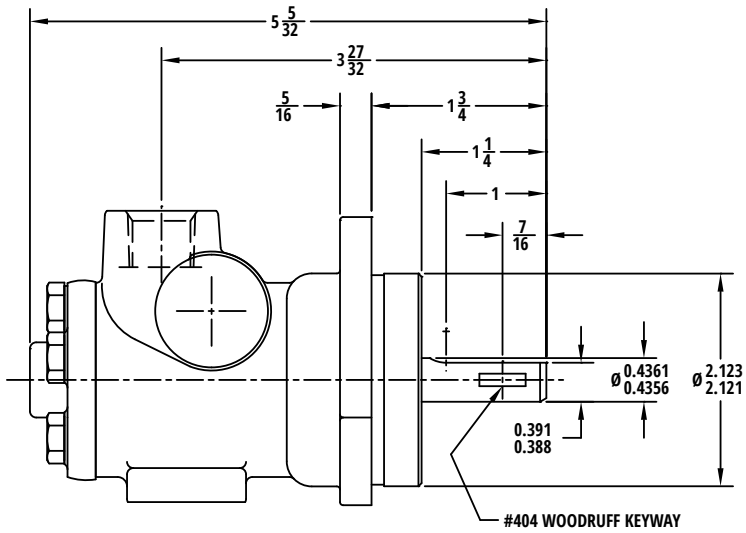

4102-4105 Pump Mounting Dimensions

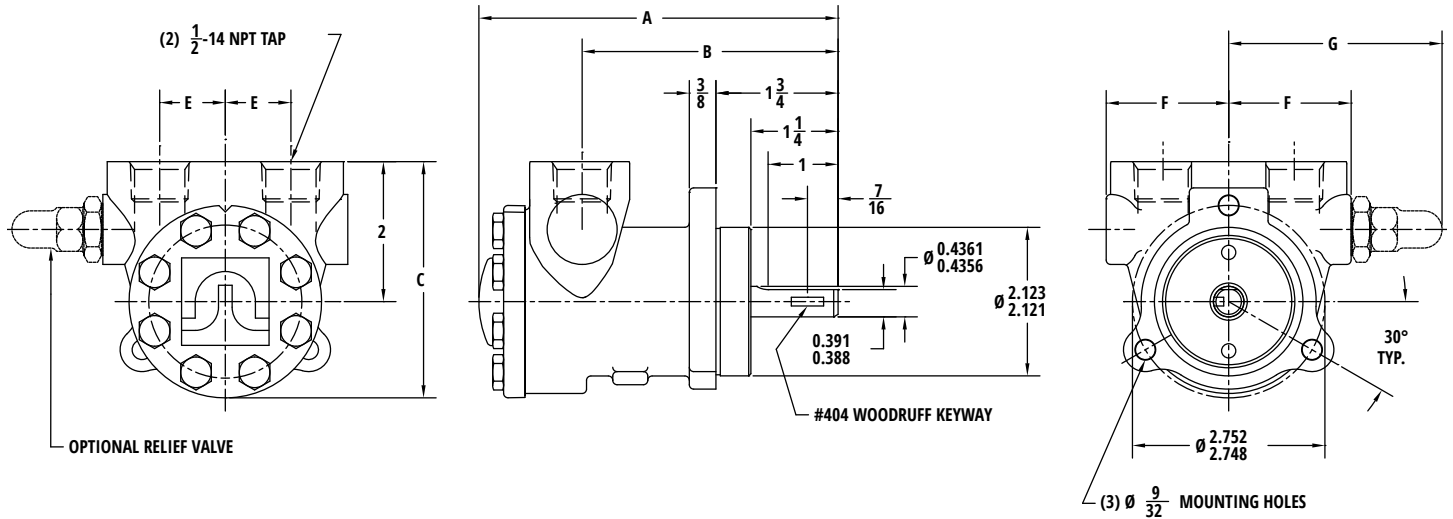

Pump Model	Overall Length (A)	B	C	E	F	G
4102	4 15/16	3 15/32	3 15/32	15/16	1 29/32	3 3/32
4103	4 15/16	3 15/32	3 15/32	15/16	1 29/32	3 3/32
4104	5 3/32	3 5/8	3 5/16	15/16	1 3/4	3 1/8
4105	5 15/16	4 7/16	3 5/8	15/16	1 7/8	3 1/8

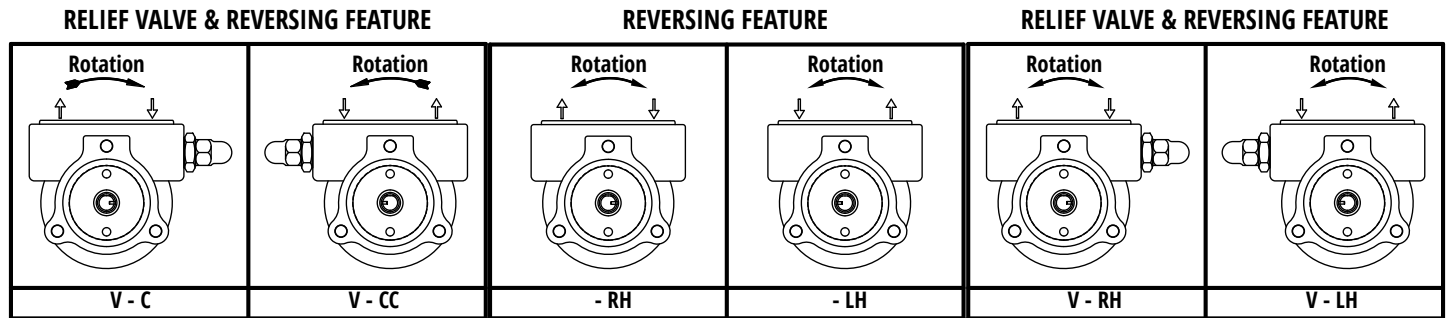

SHAFT END VIEW

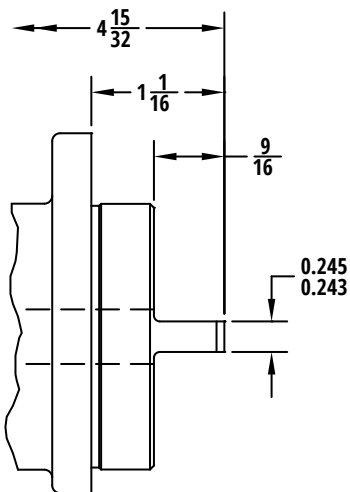

Port Size	Pump Model			
	4102	4103	4104	4105
1/2" - 14 NPT	Std.	Std.	Std.	Std.
3/4" - 16 UNF (SAE8)	Opt.	Opt.	Opt.	Opt.

MODIFICATION "A"

4108 Pump Mounting Dimensions

PORT TYPES

1" - 11 1/2 NPT / STD

1 5/16" - 16 UNF (SAE16) Opt.

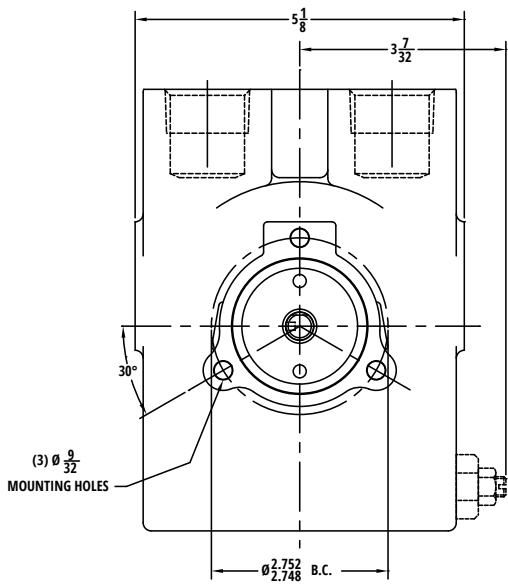
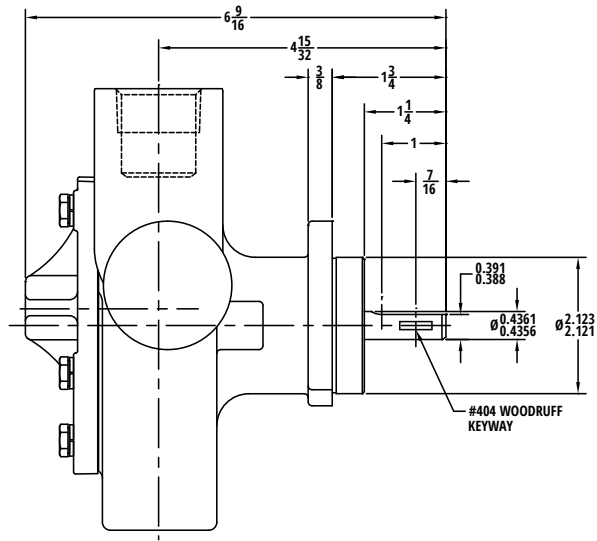
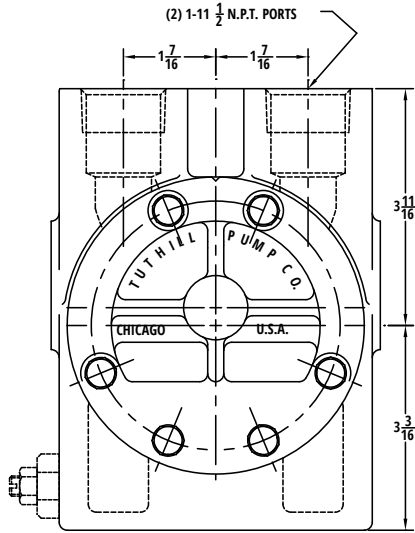

RELIEF VALVE & REVERSING FEATURE

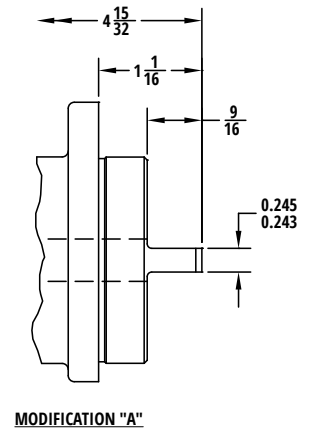
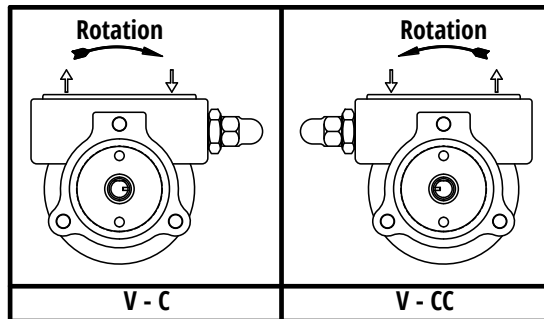

4100 Pump Model Number System

	Pump		Sub-Group	Size	Pump Options	Rotations Valved Models		Modifications
Position #	1	2	3	4	5	6	7	8

Position #	Description	Codes
1 & 2	Pump	-41
3	Sub-Group	-0 = Standard Design or -2 = Abrasion Resistant Design (Contact Factory)
4	Size	-1, -2, -3, -4, -5, or -8
5	Pump Options	-V = Relief Valve, -K = Ball Bearing, or -U = Cover Rotated 180°
6 & 7	Rotation (Valved Models)	-C = Clockwise or -CC = Counterclockwise
8	Modifications	-A = Tang Shaft, -5 = Neoprene Seal, or -7 = Viton Seal

- 1.) PUMP'S MODEL NUMBER IS LOCATED IN BETWEEN THE PUMP PORTS.
- 2.) ROTATION AND SUCTION (IN) AND DISCHARGE (OUT) ARE STAMPED AS WELL.
- 3.) SIZE 8 MODEL NUMBER IS STAMPED ON A METAL TAG ATTACHED TO THE COVER

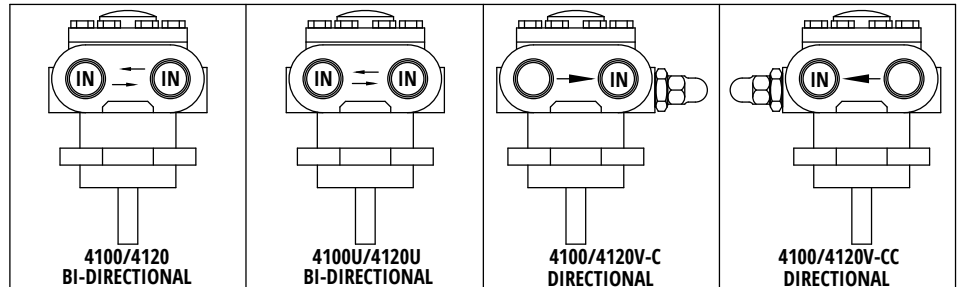
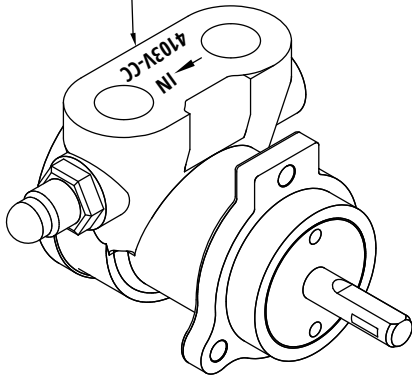

4100 Pump Temperature Limits

600 °F	Ceramic Bushing (Contact Factory)	Carbon Bushings	Viton	Neoprene	315 °C
500 °F					260 °C
450 °F					232 °C
400 °F					204 °C
370 °F					187 °C
350 °F					177 °C
300 °F					149 °C
250 °F					121 °C
200 °F					93 °C
150 °F					66 °C
100 °F					38 °C
50 °F					10 °C
-10 °F					-23 °C
-40 °F					-40 °C
-50 °F					-46 °C
-100 °F					-73 °C

Notes: A pump's performance is dependent on more than just the temperature ranges of the component materials.

4100 Pump Materials of Construction

Part Name	Material	Standard	Comments	Availability
Housing	Cast Iron	ASTM A48 – 96a	Classes 30, 35, or 40	Std.
Housing Bushing	Carbon	Carbon Graphite Resin		Std.
	Ceramic	Alumina Ceramic, Diamonite	Standard on 4120 Models	Opt.
Cover	Cast Iron	ASTM A48 – 96a	Classes 30, 35, or 40	Std.
	Cast Iron	ASTM A48 – 96a	Heat Treated (Standard on 4120 Models)	Opt.
Rotor	Steel	ASTM A311	Stressproof	Std.
	Steel	ASTM A311	Stressproof and Heat Treated (Standard on 4120 Models)	Opt.
Idler	Steel	C1118 or C1117		Std.
	Plastic	PPS	On 4101 size only	Std.
Idler Pin	Steel	C1117	Heat Treated	Std.
Idler Bushing	Carbon	Carbon Graphite Resin		Std.
Housing Plug	Steel	AISI 12L14	DU Bushing is assembled in housing plug	Std.
Gaskets	Standard	Oriented Polyester		Std.
	Standard	Buna Coated Aluminum	Available on 2L size only	Std.
O-Rings	Viton			STD
	Neoprene			Opt.

L/4100/Cartridge Pump NPSH Data

NPSH Required for Tuthill "L/4100/Cartridge" Series Pumps 0-1000 SSU

Pump Series	NPSH (Units)	300 RPM	600 RPM	900 RPM	1200 RPM	1500 RPM	1800 RPM
30L & 4101	FT.		1.0	1.7	1.9	2.1	2.3
00L & 4102	FT.		1.0	1.7	2.0	2.3	2.6
0L & 4103	FT.		1.0	1.8	2.2	2.5	2.9
1L & 4104	FT.		1.1	1.8	2.3	2.9	3.5
2L & 4105	FT.	1.1	2.3	3.0	3.8	5.8	7.0
5L & 4108	FT.	1.7	2.8	4.6	6.6	9.2	12.3

Notes: For liquid viscosity up to 1000 SSU. NPSHA (Net Positive Suction Head Available) must be greater than the NPSHR (Net Positive Suction Head Required) value provided in the table. Values above are for feet of liquid with a Specific Gravity of 1.0.

Viscosity Correction Factor

2500 SSU	5000 SSU	10000 SSU
1.3 Correction Factor	1.7 Correction Factor	2.0 Correction Factor

Dimensions for 30LE-2LE & 4101-4105 Close Coupled to a 48 Frame 1 Phase Motor

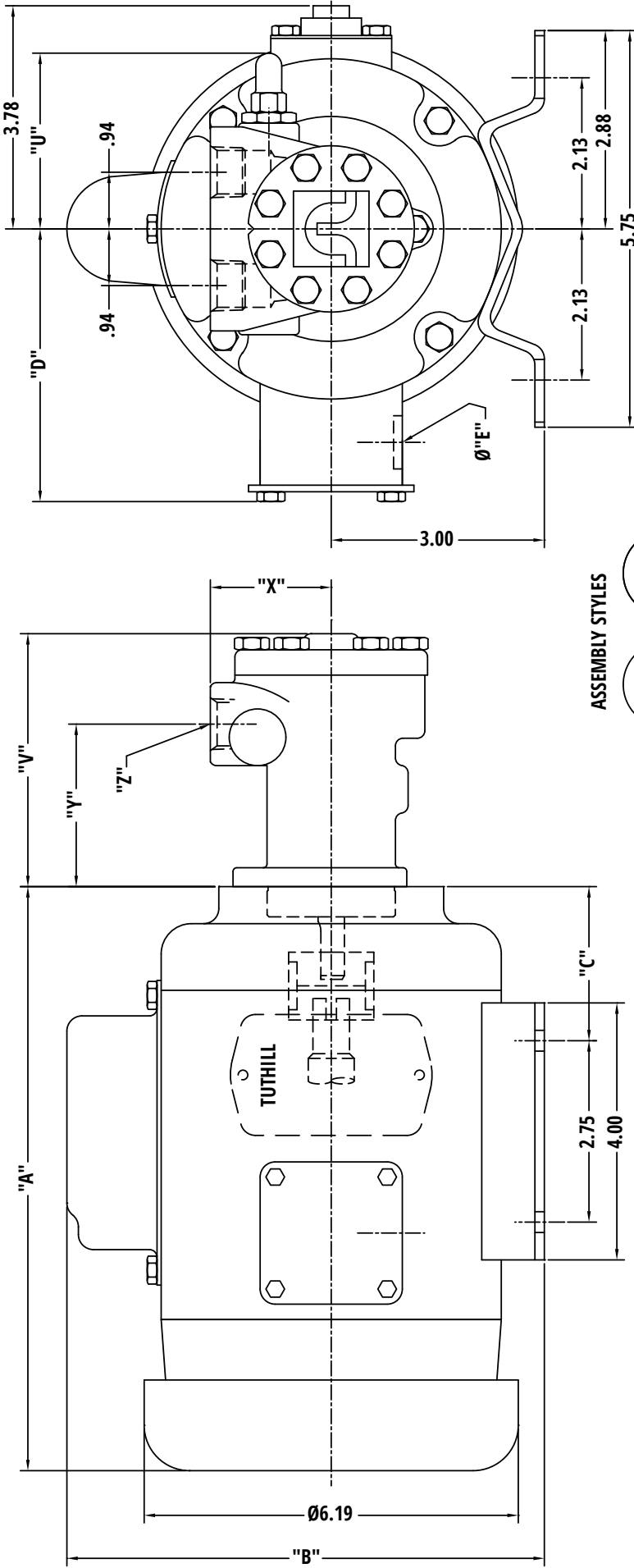

ASSEMBLY STYLES

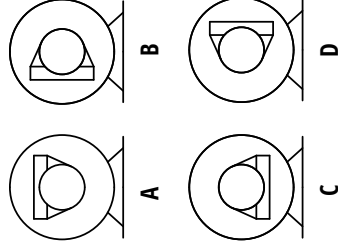

MODEL #	HP	DESCRIPTION	"A"	"B"	"C"	"D"	"E"	WT. (LBS)
88514	1/4	1/60/115/230 VOLT, 1725 RPM, TEFC, 48VZ FRAME	9.60	7.41	2.50	4.51	.88	23
88600	1/4	1/60/115/230 VOLT, 1725 RPM, XPFC, 48VZ FRAME	12.95	5.84	4.11	6.50	.50	38
88513	1/3	1/60/115/230 VOLT, 1725 RPM, TEFC, 48VZ FRAME	9.60	7.41	2.50	4.51	.88	26
88516	1/2	1/60/115/230 VOLT, 1725 RPM, TEFC, 48VZ FRAME	9.60	7.41	2.50	4.51	.88	29

MODEL #	"U"	"V"	"X"	"Y"	"Z"-NPT
30LE & 4101	3 3/32	3 13/32	1 11/16	2 3/32	3 3/8 -18
00LE & 4102	3 3/32	3 3/16	2	1 23/32	1 -14
0LE & 4103	3 3/32	3 3/16	2	1 23/32	1 -14
1LE & 4104	3 1/8	3 11/32	2	1 7/8	1 -14
2LE & 4105	3 1/8	4 3/16	2	2 11/16	1 -14

Dimensions for 30LE-2LE & 4101-4105 Close Coupled to a 56 Frame 1 Phase Motor

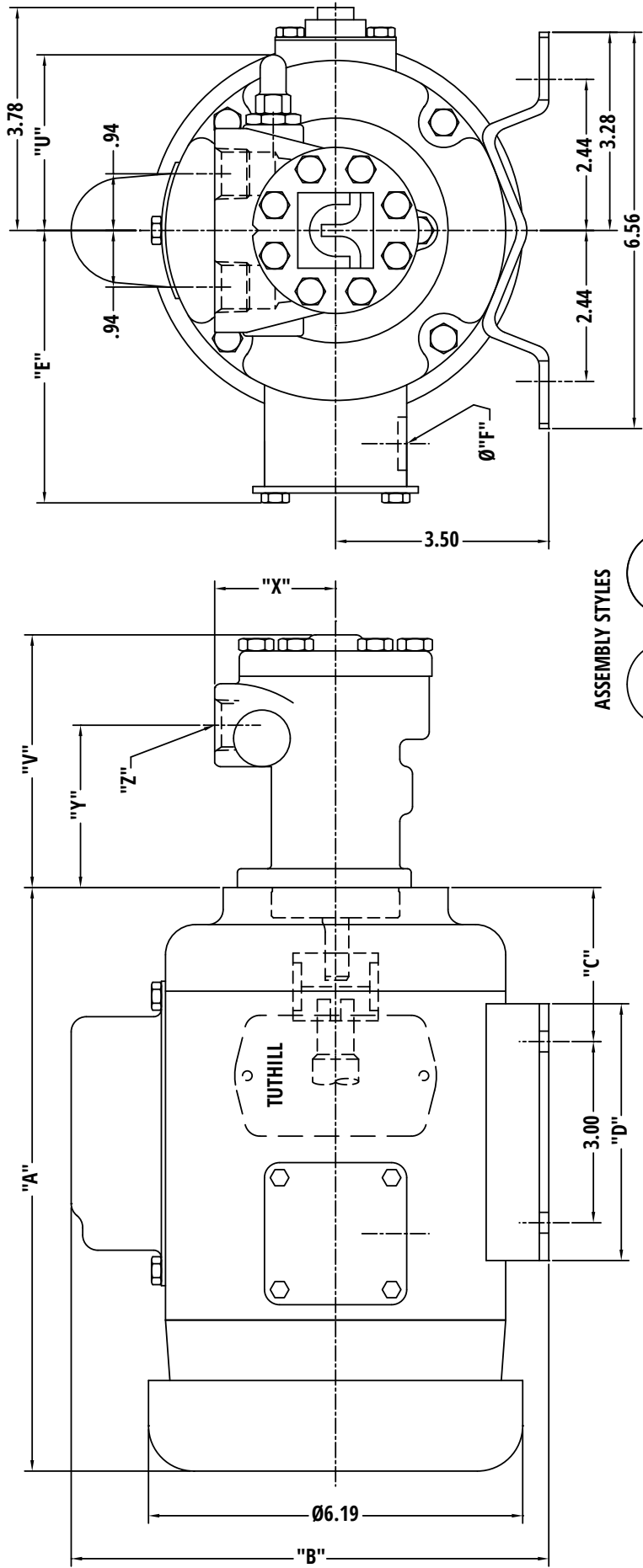

ASSEMBLY STYLES

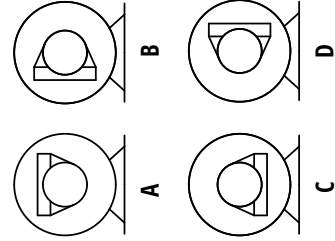

MODEL #	"U"	"V"	"X"	"Y"	"Z"-NPT
30LE & 4101	2 ¹⁵ / ₁₆	3 ¹³ / ₃₂	1 ¹¹ / ₁₆	2 ³ / ₃₂	3 ⁸ / ₁₈
00LE & 4102	2 ⁷ / ₈	3 ³ / ₁₆	2	1 ²³ / ₃₂	1 ¹⁴ / ₂
0LE & 4103	2 ⁷ / ₈	3 ³ / ₁₆	2	1 ²³ / ₃₂	1 ¹⁴ / ₂
1LE & 4104	2 ⁷ / ₈	3 ¹¹ / ₃₂	2	1 ⁷ / ₈	1 ¹⁴ / ₂
2LE & 4105	3 ¹ / ₃₂	4 ³ / ₁₆	2	2 ¹¹ / ₁₆	1 ¹⁴ / ₂

MODEL #	HP	DESCRIPTION	"A"	"B"	"C"	"D"	"E"	"F"	WT. (LBS)
88494	1/2	1/60/115/230 VOLT, 1725 RPM, TEFC, 56VZ FRAME	9.65	7.90	2.75	4.00	4.90	.88	33
88601	1/2	1/60/115/230 VOLT, 1725 RPM, XPFC, 56VZ FRAME	13.96	6.60	4.36	4.25	6.50	.50	44
88602	3/4	1/60/115/230 VOLT, 1725 RPM, TEFC, 56VZ FRAME	11.78	8.68	2.75	4.25	4.51	.88	36

Dimensions for 30LE-2LE & 4101-4105 Close Coupled to a 48 Frame 3 Phase Motor

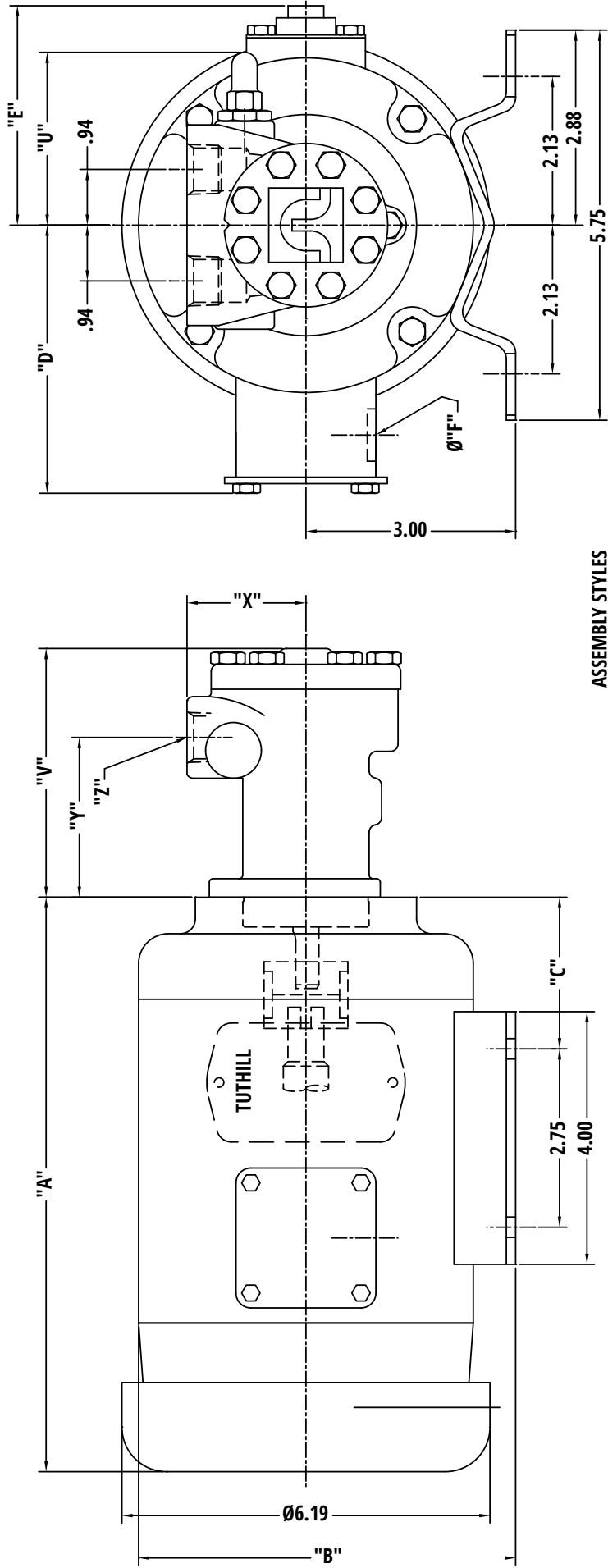

ASSEMBLY STYLES

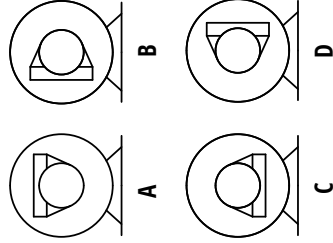

MODEL #	HP	DESCRIPTION	"A"	"B"	"C"	"D"	"E"	"F"	WT. (LBS)
88515	1/4	3PH/50/60/190-220/380-440 VOLT, 208-230/460 VOLT, 1425/1725 RPM, TEFC, 48YZ FRAME	9.10	5.84	2.50	4.90	3.78	.88	33
88603	1/4	3PH/50/60/190-220/380-440 VOLT, 208-230/460 VOLT, 1425/1725 RPM, XPFC, 48YZ FRAME	12.95	6.10	4.11	6.50	-	.50	33
88495	1/3	3PH/50/60/190-220/380-440 VOLT, 208-230/460 VOLT, 1425/1725 RPM, TEFC, 48YZ FRAME	9.10	5.84	2.50	4.90	3.78	.88	33
88519	1/2	3PH/50/60/190-220/380-440 VOLT, 208-230/460 VOLT, 1425/1725 RPM, TEFC, 48YZ FRAME	9.10	5.84	2.50	4.90	3.78	.88	33

MODEL #	"U"	"V"	"X"	"Y"	"Z"-NPT
30LE & 4101	3 ³ / ₃₂	3 ¹³ / ₃₂	1 ¹¹ / ₁₆	2 ³ / ₃₂	3 ³ / ₈ -18
00LE & 4102	3 ³ / ₃₂	3 ³ / ₁₆	2	1 ²³ / ₃₂	1-14
0LE & 4103	3 ³ / ₃₂	3 ³ / ₁₆	2	1 ²³ / ₃₂	1-14
1LE & 4104	3 ¹ / ₈	3 ¹¹ / ₃₂	2	1 ⁷ / ₈	1-14
2LE & 4105	3 ¹ / ₈	4 ³ / ₁₆	2	2 ¹¹ / ₁₆	1-14

Dimensions for 30LE-2LE & 4101-4105 Close Coupled to a 56 Frame 3 Phase Motor

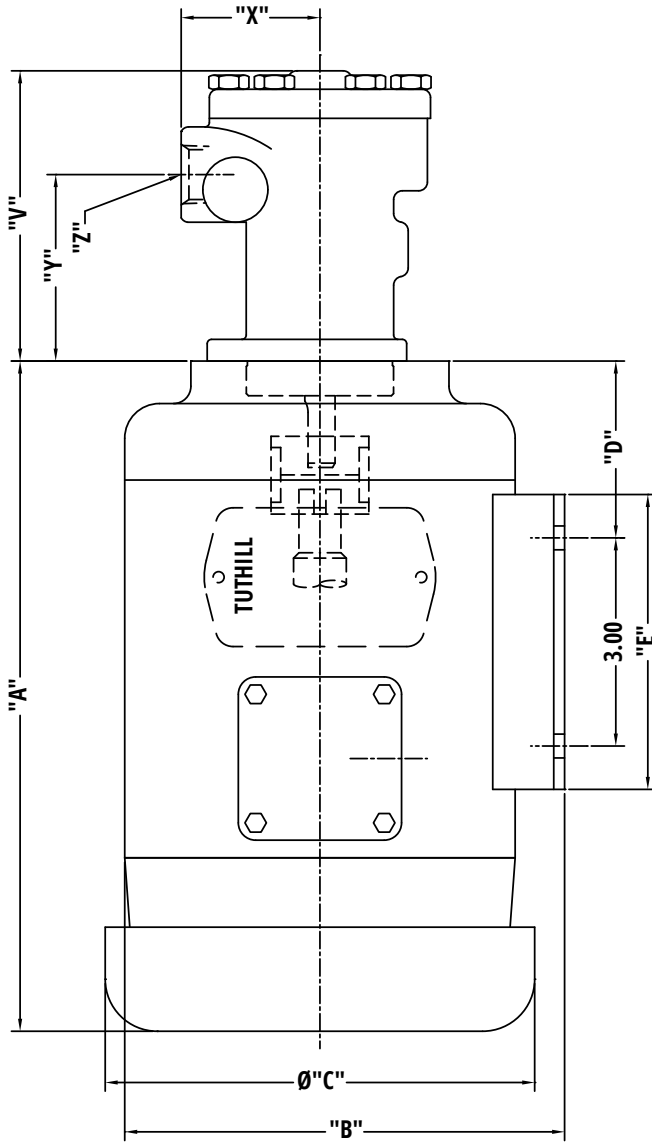
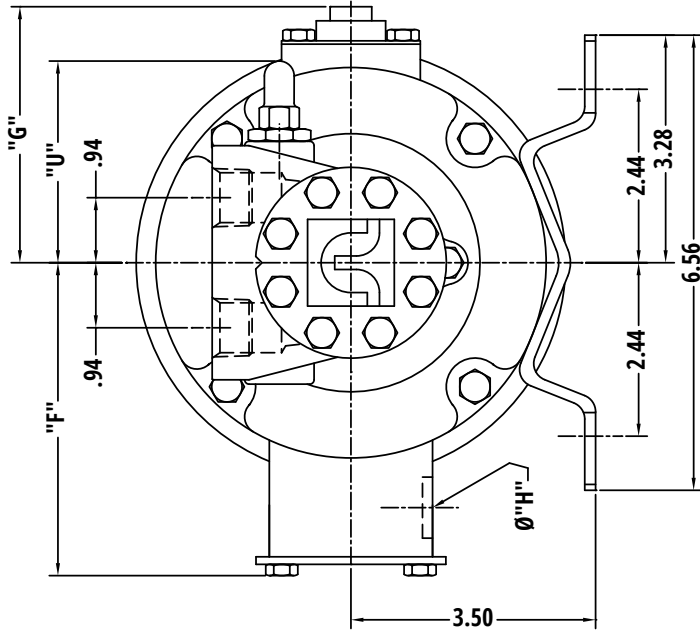

MODEL #	"U"	"V"	"X"	"Y"	"Z"-NPT
30LE & 4101	3 $\frac{3}{32}$	3 $\frac{13}{32}$	1 $\frac{11}{16}$	2 $\frac{3}{32}$	3-18 $\frac{3}{8}$
00LE & 4102	3 $\frac{3}{32}$	3 $\frac{3}{16}$	2	1 $\frac{23}{32}$	1-14 $\frac{1}{2}$
0LE & 4103	3 $\frac{3}{32}$	3 $\frac{3}{16}$	2	1 $\frac{23}{32}$	1-14 $\frac{1}{2}$
1LE & 4104	3 $\frac{1}{8}$	3 $\frac{11}{16}$	2	1 $\frac{7}{8}$	1-14 $\frac{1}{2}$
2LE & 4105	3 $\frac{1}{8}$	4 $\frac{3}{16}$	2	2 $\frac{11}{16}$	1-14 $\frac{1}{2}$

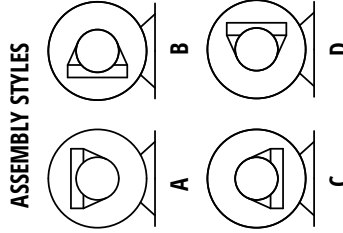

MODEL #	HP	DESCRIPTION	"A"	"B"	"C"	"D"	"E"	"F"	"G"	"H"	WT.
88520	1/2	3PH/50//60/190-220/380-440 VOLT, 208-230/460 VOLT, 1425/1725 RPM, TEFC, 56YZ FRAME	9.78	6.34	6.19	2.75	4.25	4.51	3.69	.88	30
88604	1/2	3PH/50//60/190-220/380-440 VOLT, 208-230/460 VOLT, 1425/1725 RPM, XPFC, 56YZ FRAME	13.96	6.60	6.20	4.36	4.25	6.50	-	.50	42
88521	3/4	3PH/50//60/190-220/380-440 VOLT, 208-230/460 VOLT, 1425/1725 RPM, TEFC, 56YZ FRAME	10.36	6.83	7.19	2.84	4.50	5.20	4.19	.88	36
88605	1	3PH/50//60/190-220/380-440 VOLT, 208-230/460 VOLT, 1425/1725 RPM, TEFC, 56YZ FRAME	10.36	6.83	7.19	2.84	4.50	5.20	4.19	.88	36
88606	1 1/2	3PH/50//60/190-220/380-440 VOLT, 208-230/460 VOLT, 1425/1725 RPM, TEFC, 56YZ FRAME	11.36	6.83	7.19	2.84	4.50	5.20	4.19	.88	40

Dimensions for 5LE & 4108 Close Coupled to a 56 Frame 1 Phase Motor

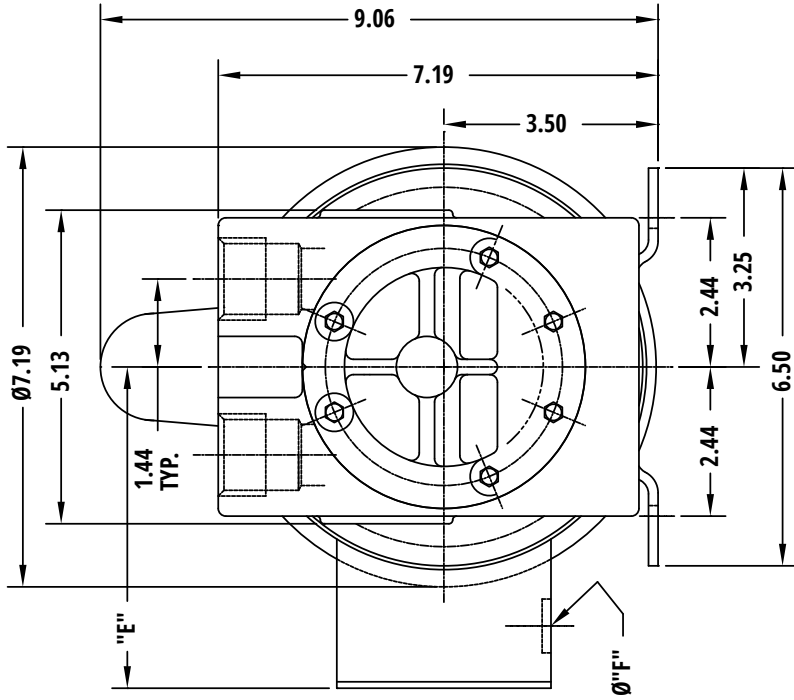
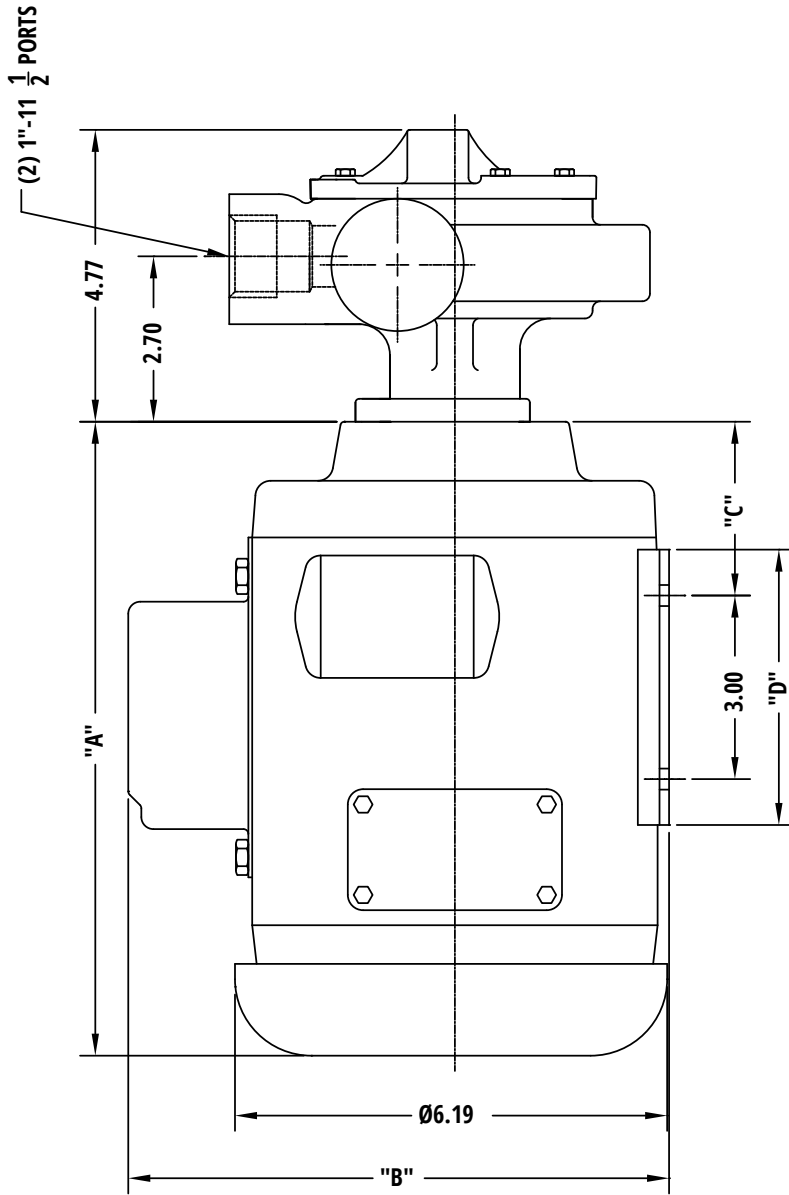

ASSEMBLY STYLES

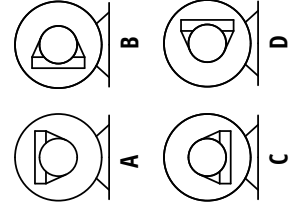

MODEL #	HP	DESCRIPTION	"A"	"B"	"C"	"D"	"E"	"F"	WT. (LBS)
88494	1/2	1/60/115/230 VOLT, 1725 RPM, TEFC, 56YZ FRAME	9.65	7.90	2.75	4.00	4.90	.88	33
88601	1/2	1/60/115/230 VOLT, 1725 RPM, XPFC, 56YZ FRAME	13.96	6.60	4.36	4.25	6.50	.50	44
88602	3/4	1/60/115/230 VOLT, 1725 RPM, TEFC, 56YZ FRAME	11.78	8.68	2.75	4.25	4.51	.88	36

Dimensions for 5LE & 4108 Close Coupled to a 56 Frame 3 Phase Motor

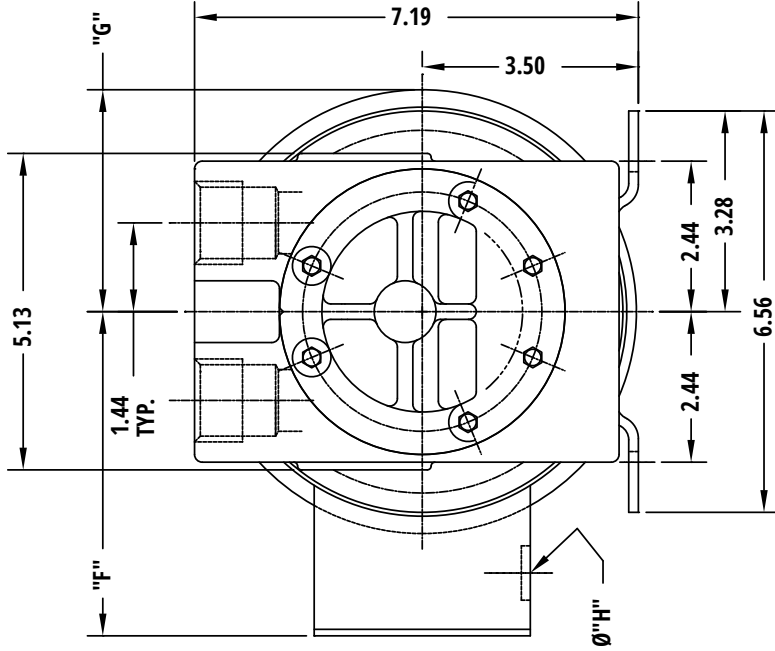
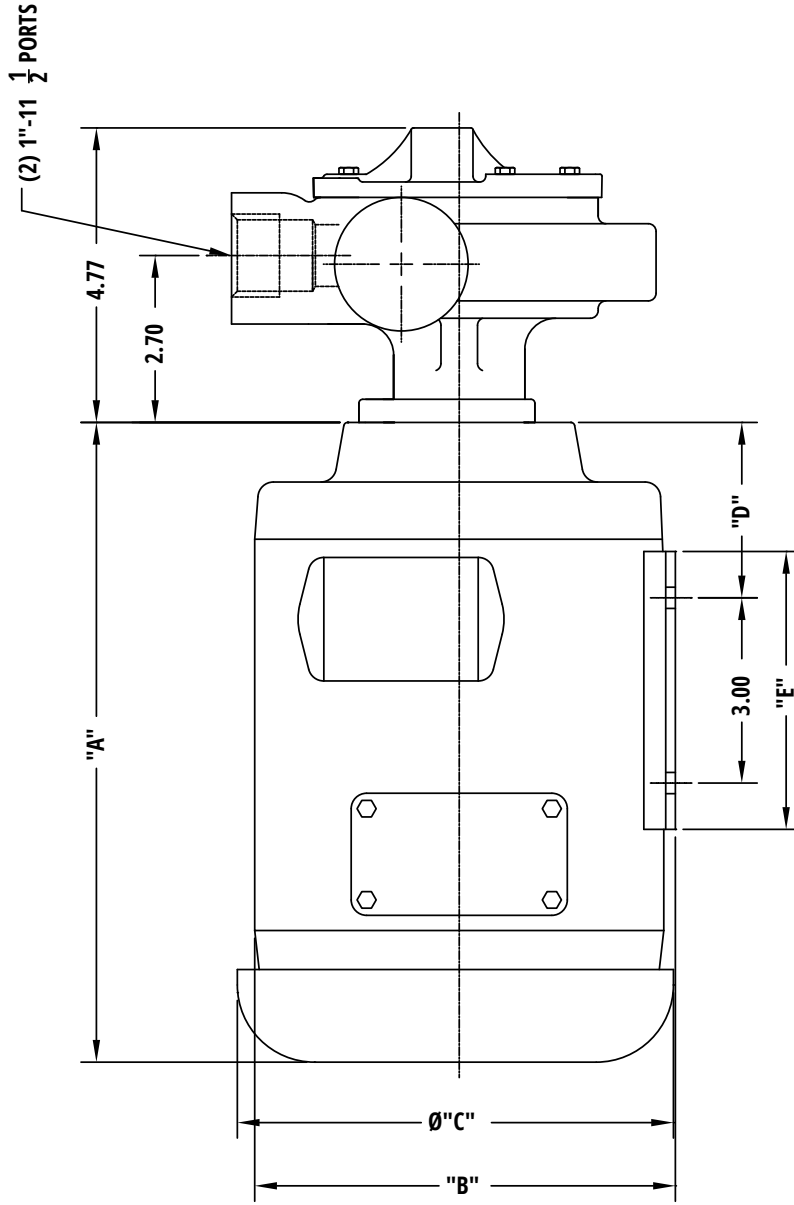

ASSEMBLY STYLES

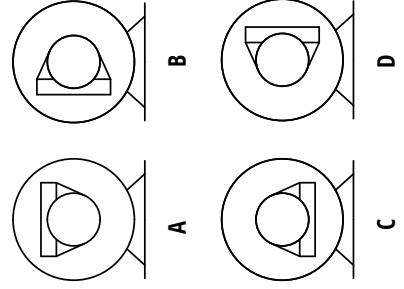

MODEL #	HP	DESCRIPTION	"A"	"B"	"C"	"D"	"E"	"F"	"G"	"H"	WT.
88520	1/2	3PH/50/60/190-220/380-440 VOLT, 208-230/460 VOLT, 1425/1725 RPM, TEFC, 56YZ FRAME	9.78	6.34	6.19	2.75	4.25	4.51	3.69	.88	30
88604	1/2	3PH/50/60/190-220/380-440 VOLT, 208-230/460 VOLT, 1425/1725 RPM, XPFC, 56YZ FRAME	13.96	6.60	6.20	4.36	4.25	6.50	-	.50	42
88521	3/4	3PH/50/60/190-220/380-440 VOLT, 208-230/460 VOLT, 1425/1725 RPM, TEFC, 56YZ FRAME	10.36	6.83	7.19	2.84	4.50	5.20	4.19	.88	36
88605	1	3PH/50/60/190-220/380-440 VOLT, 208-230/460 VOLT, 1425/1725 RPM, TEFC, 56YZ FRAME	10.36	6.83	7.19	2.84	4.50	5.20	4.19	.88	36
88606	1 1/2	3PH/50/60/190-220/380-440 VOLT, 208-230/460 VOLT, 1425/1725 RPM, TEFC, 56YZ FRAME	11.36	6.83	7.19	2.84	4.50	5.20	4.19	.88	40

Dimensions for 30LE-2LE & 4101-4105 Adapter Mounted to a 56 Frame Single & 3 Phase Motor

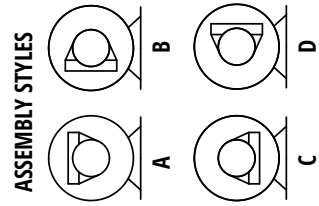
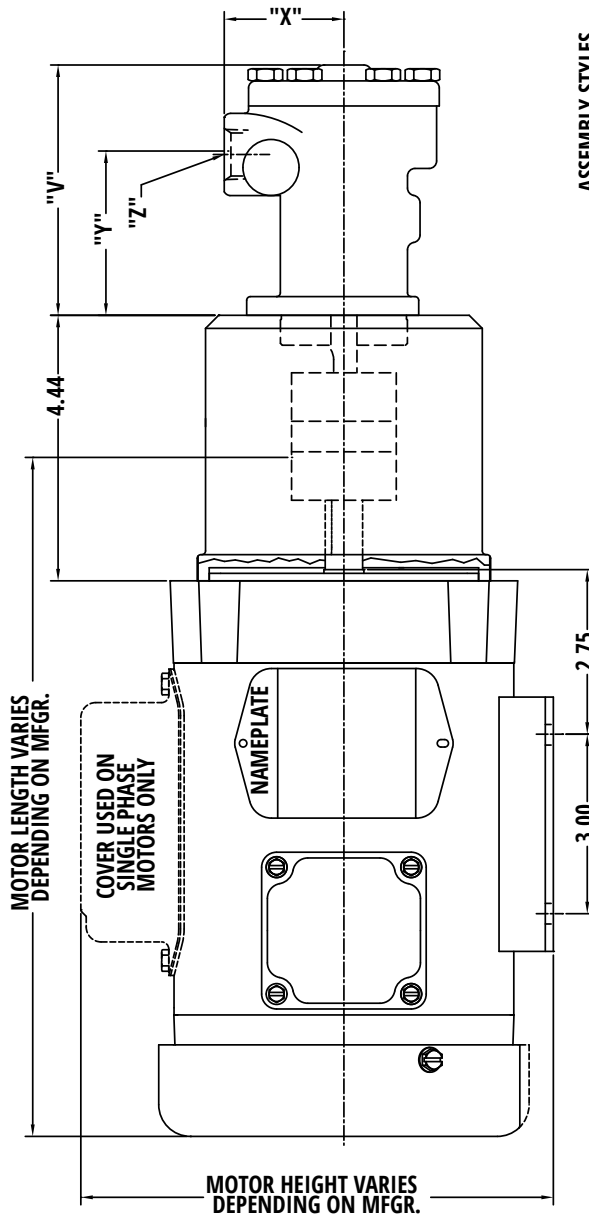
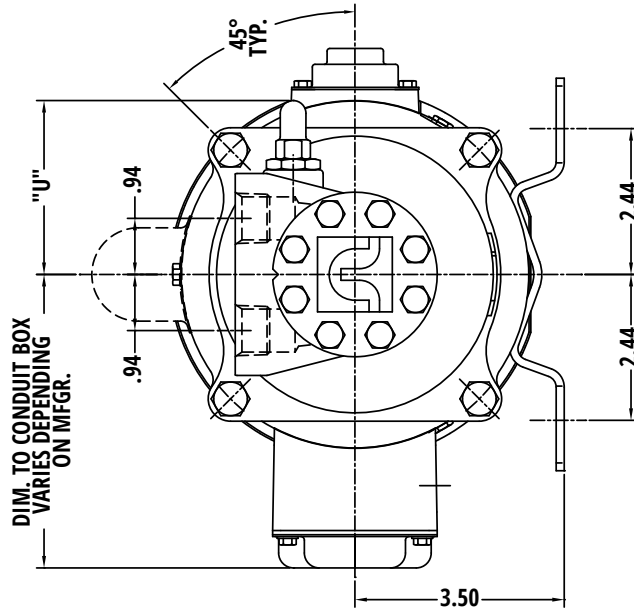

MODEL #	"U"	"V"	"X"	"Y"	"Z"-NPT
30LE & 4101	3 3/32	3 13/32	1 11/16	2 3/32	3/8 - 18
00LE & 4102	3 3/32	3 3/16	2	1 23/32	1/2 - 14
01LE & 4103	3 3/32	3 3/16	2	1 23/32	1/2 - 14
11LE & 4104	3 8/16	3 11/16	2	1 7/8	1/2 - 14
21LE & 4105	3 1/8	4 3/16	2	2 11/16	1/2 - 14

Dimensions for 30LE-2LE & 4101-4105 Adapter Mounted to a 143/145TC Frame Single & 3 Phase Motor

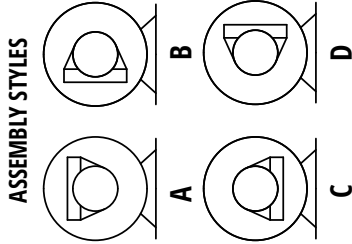
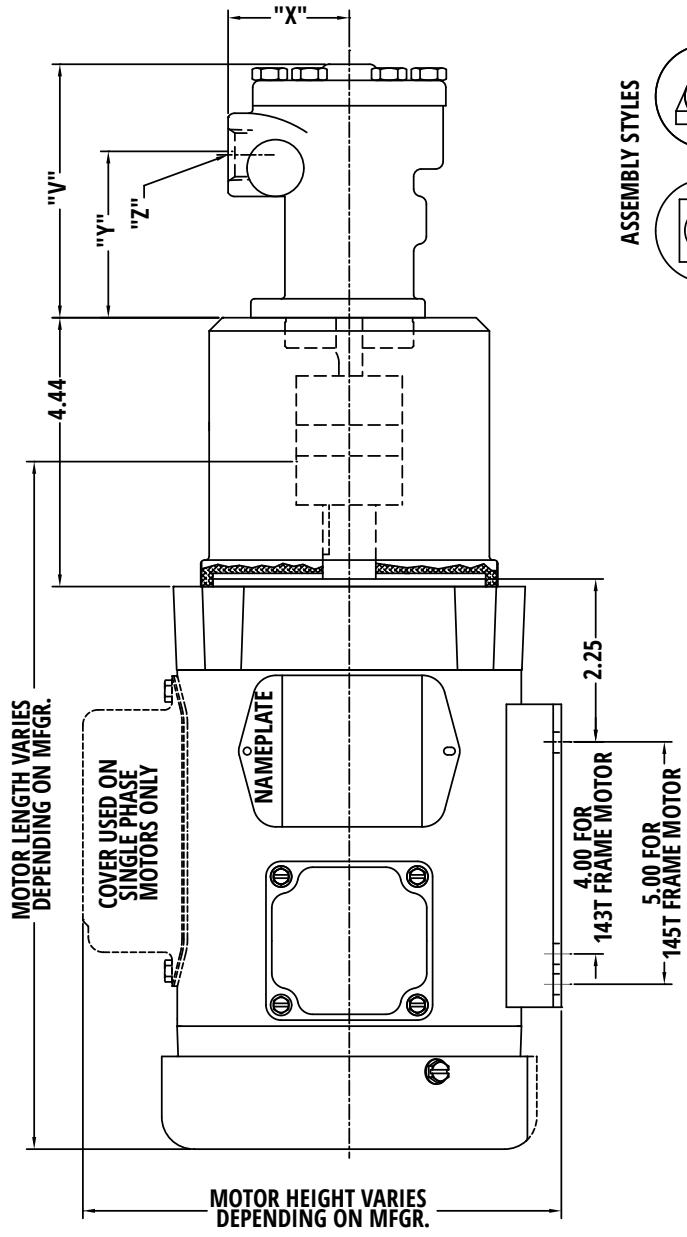
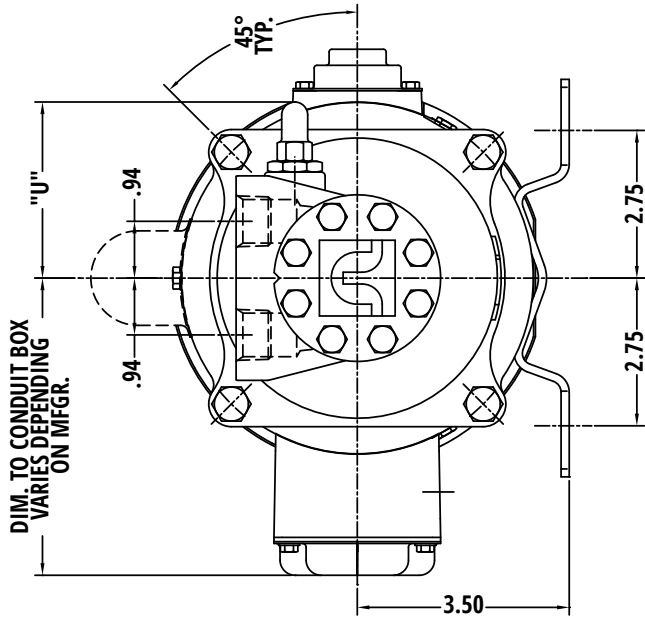

MODEL #	"U"	"V"	"X"	"Y"	"Z"-NPT
30LE & 4101	3 $\frac{3}{32}$	3 $\frac{13}{32}$	1 $\frac{11}{16}$	2 $\frac{3}{8}$	3 $\frac{18}{8}$
00LE & 4102	3 $\frac{3}{32}$	3 $\frac{3}{16}$	2	1 $\frac{23}{32}$	1 $\frac{14}{2}$
01LE & 4103	3 $\frac{3}{32}$	3 $\frac{3}{16}$	2	1 $\frac{23}{32}$	1 $\frac{14}{2}$
1LE & 4104	3 $\frac{1}{8}$	3 $\frac{11}{32}$	2	1 $\frac{7}{8}$	1 $\frac{14}{2}$
2LE & 4105	3 $\frac{1}{8}$	4 $\frac{3}{16}$	2	2 $\frac{11}{16}$	1 $\frac{14}{2}$

Dimensions for 5LE & 4108 Adapter Mounted to a 56 Frame 1 & 3 Phase Motor

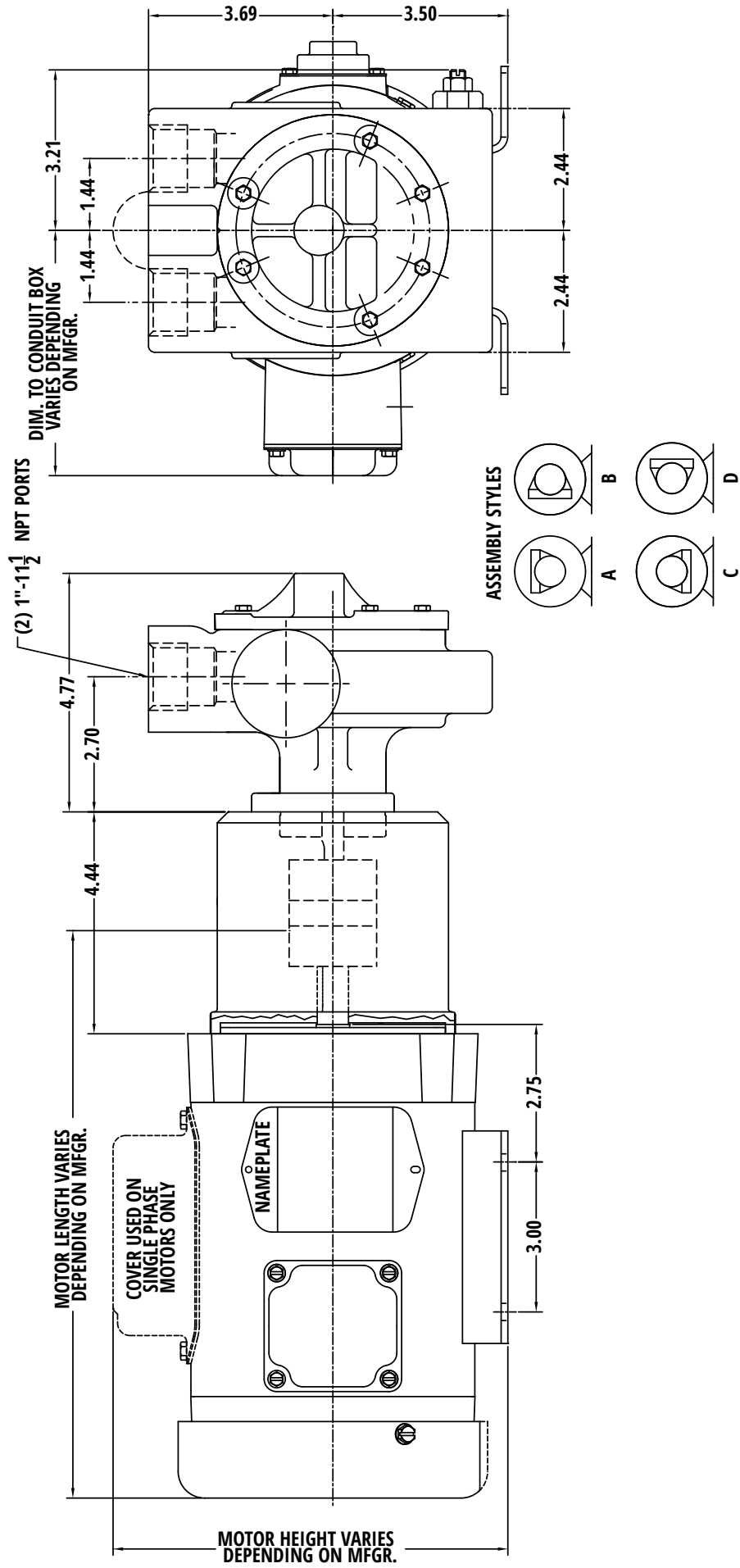

Dimensions for 5LE, 4108 & 4128 Adapter Mounted to a 143/145TC Frame 1 & 3 Phase Motor

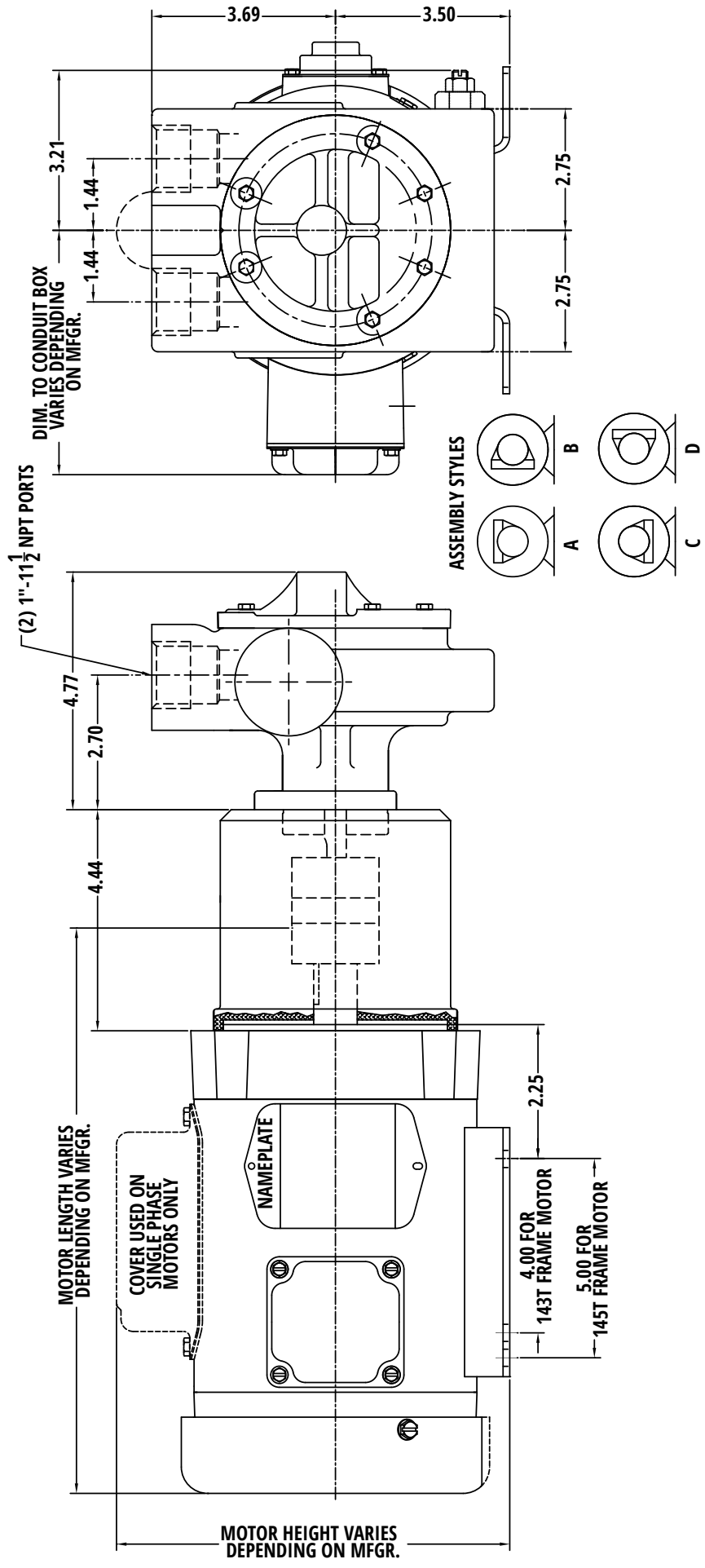

Dimensions for LE Series Mounting Foot (0L81-C)

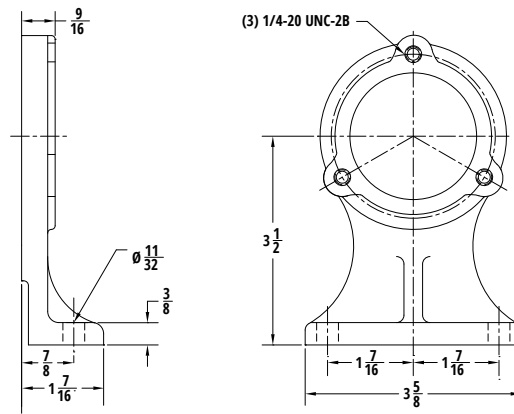

0ORF, ORF, & 1RF Pump Mounting Dimensions

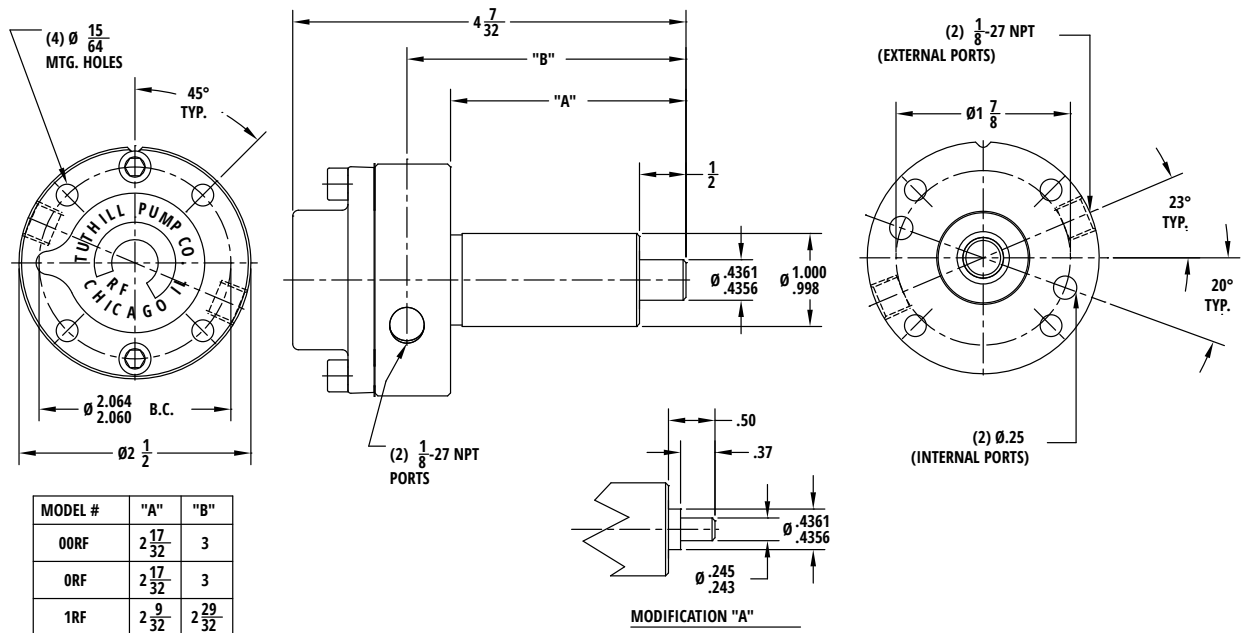

1R1F-A Pump Mounting Dimensions

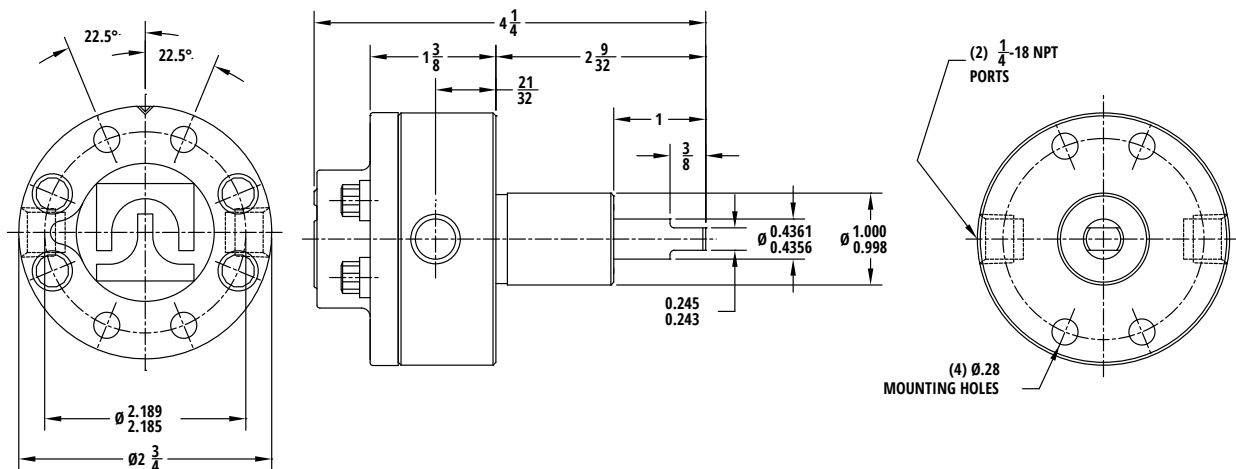

00LFD, 0LFD, 1LFD, 00RFD, 0RFD, & 1RFD Pump Mounting Dimensions

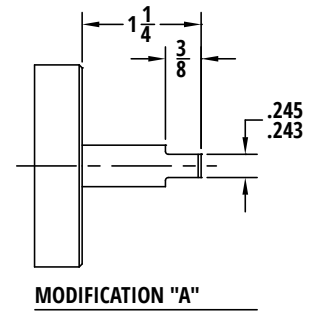
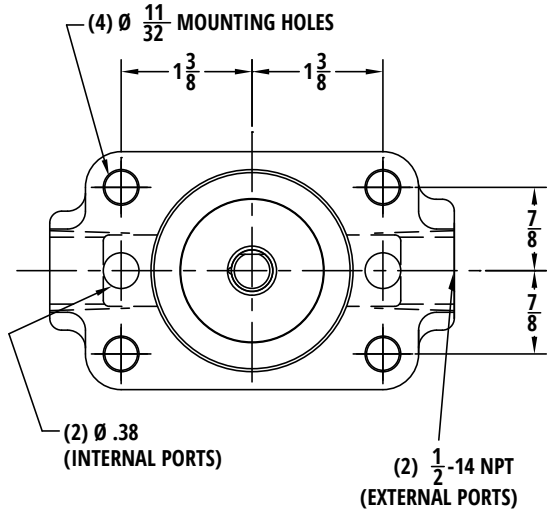
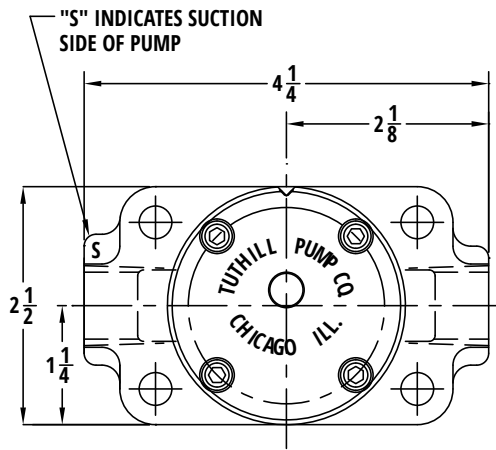

00RFD, 0RFD, AND 1RFD
(DIFFERENCE IN COVER)

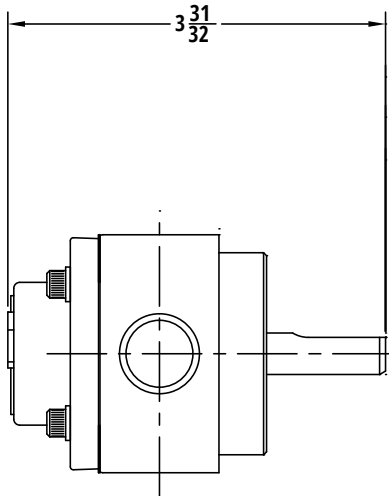

00LFD, 0LFD, AND 1LFD

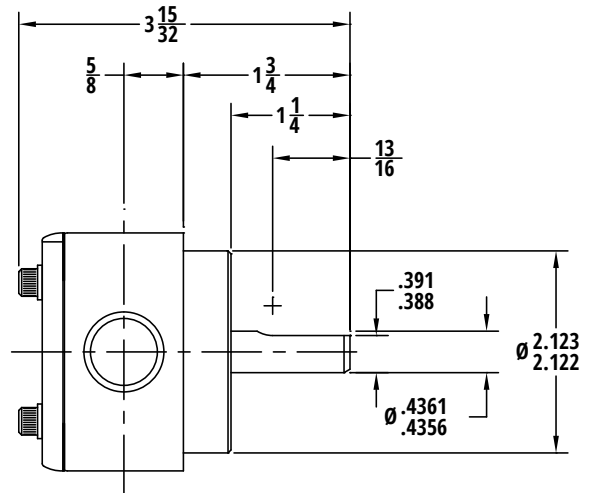

2LFD & 2RFD Pump Mounting Dimensions

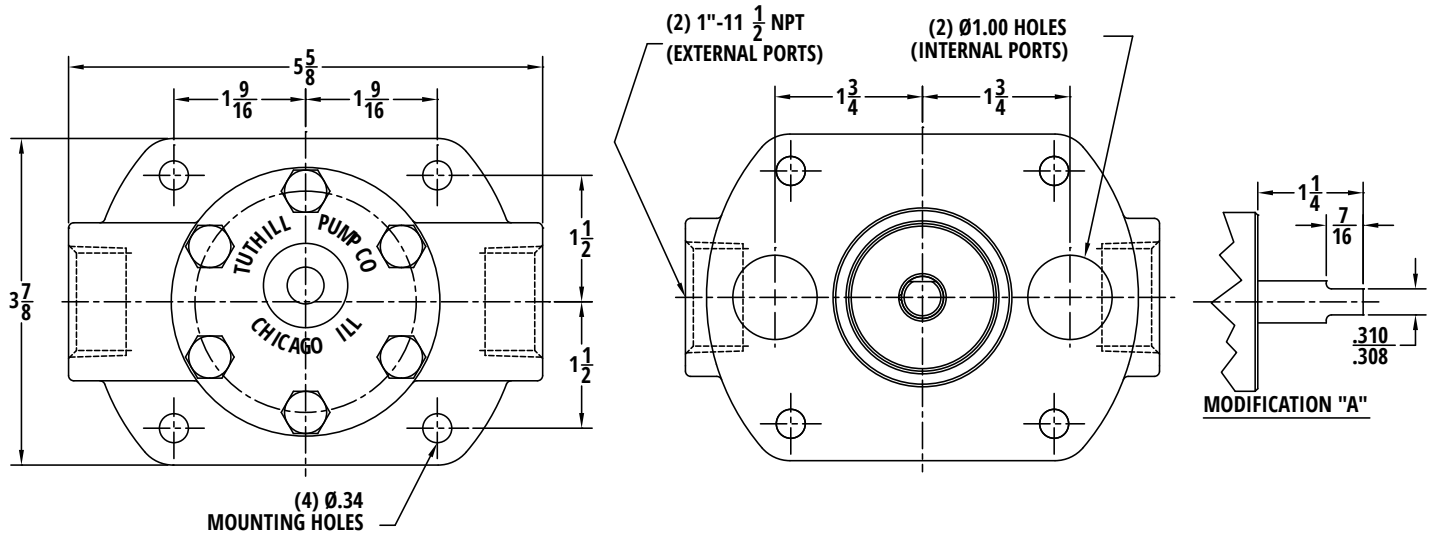

2RFD
(DIFFERENCE IN COVER)

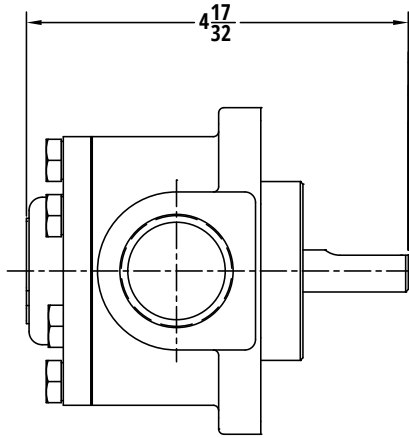

2LFD

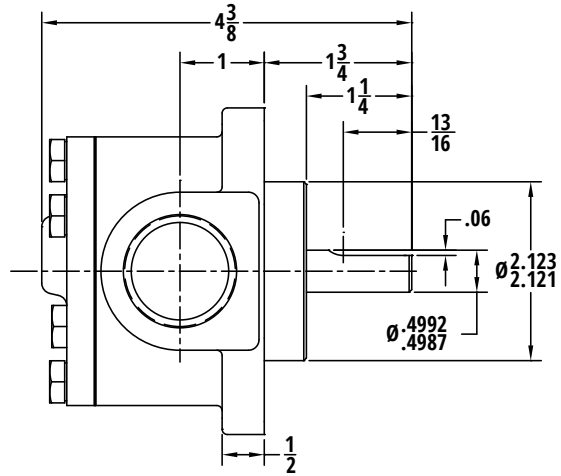

Cartridge Pump Model Number System

	Size		Model			Pump Options	Rotation		Modifications
Position #	1	2	3	4	5	6	7	8	9

Position #	Description	Codes
1 & 2	Size	-00, -0, -1, or -2
3, 4, & 5	Model	-LFD or RFD
6	Pump Options	-B-7 = Shaft Lip Seal (Viton), -U = Cover Rotated 180°, or (-K = Outboard Ball Bearing (Available on 00 - 1 Size LFD & RFD Models))
7 & 8	Rotation (Valved Models)	-C = Clockwise Rotation or -CC = Counterclockwise
9	Modifications	-A = Tang Shaft, -1 = External Ports, -2 = Internal/External Ports, or -7 = Vton Seal

Note: -RF is no longer available.

Cartridge Pump Materials of Construction

Part Name	Material	Standard	Comments	Availability
Housing	Cast Iron	ASTM A48 – 96a	Classes 30, 35, or 40	Std.
Housing Bushing	Steel	AISI 12L14		Std.
Cover	Cast Iron	ASTM A48 – 96a	Classes 25, 30, 35, or 40	Std.
Rotor	Steel	ASTM A311	Stressproof	Std.
Idler	P/M Steel	MPIF-0508-P		Std.
	Steel	C1118 or C1117		Opt.
Idler Pin	Steel	C1117	Heat Treated	Std.
Idler Bushing	Bronze	SAE 660		Opt.
	Carbon	Carbon Graphite Resin		Opt.
Gaskets	Oriented Polyester			Std.
	Buna Coated Aluminum			Std.
Seal	Viton			Std.

Model Number Locations

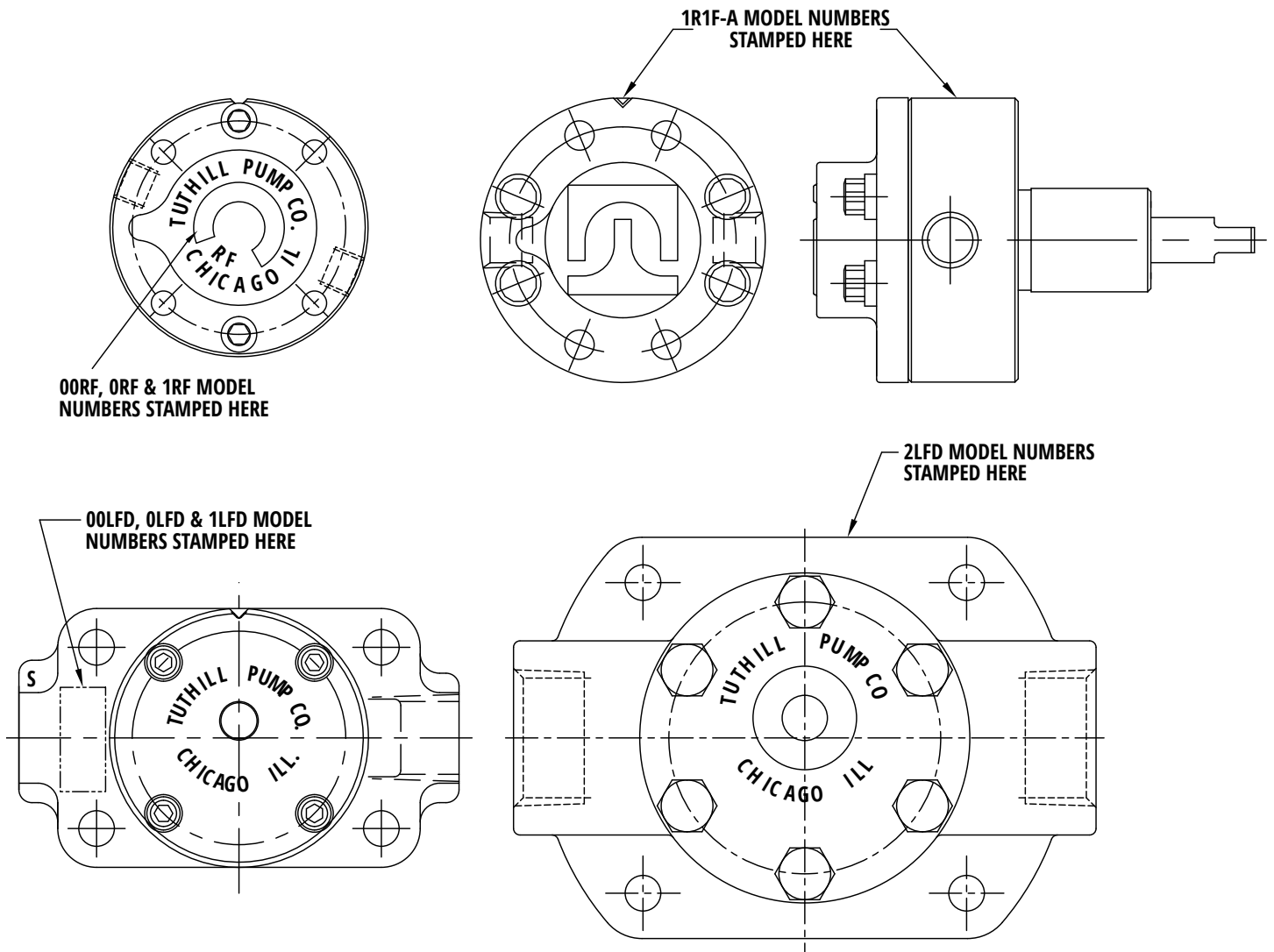

Tuthill Pump Group

12500 S. Pulaski Road, Alsip, IL 60803

www.tuthillpump.com

Excellence at work. Excellence in life.