



**Waukesha  
Cherry-Burrell**

® An SPX Process Equipment Operation

**Operation and Maintenance Manual  
Universal II Series  
Silicone-Free Automotive Paint Pump**



**Model AP015UII  
AP030UII  
AP045UII  
AP060UII**

**Read and understand this manual  
prior to installing, operating or servicing this equipment.**





611 Sugar Creek Road  
Delavan, WI 53115 USA

Tel: 1.800.252.5200 (within the USA) • (262)728.1900  
Fax: 1.800.252.5012 (within the USA) • (262)728.4904

E-mail: [custserv@gowcb.com](mailto:custserv@gowcb.com)  
Web site: [www.gowcb.com](http://www.gowcb.com)

Information contained in this manual is subject to change without notice and does not represent a commitment on the part of Waukesha Cherry-Burrell. No part of this manual may be reproduced or transmitted in any form or by any means, electronic or mechanical, including photocopying and recording, for any purpose, without the express written permission of Waukesha Cherry-Burrell.

Copyright © 2003 All Rights Reserved.

Gore-Tex is a registered trademark of W.L. Gore & Associates, Inc.  
Kalrez is a registered trademark of DuPont Dow Elastomers.

Issued Date: **August 2003**  
Revision Date: **February 2005**

Publication: **95-03056**

# Table of Contents

<b>Waukesha Cherry-Burrell Warranty .....</b>	<b>6</b>
Shipping Damage or Loss .....	6
Warranty Claim .....	6
<b>Safety .....</b>	<b>7</b>
<b>Replacement Labels .....</b>	<b>8</b>
Application Instructions .....	8
<b>Care of Stainless Steel .....</b>	<b>9</b>
Stainless Steel Corrosion .....	9
Alloy 88 .....	9
Elastomer Seal Replacement Following Passivation .....	9
<b>Introduction .....</b>	<b>10</b>
Pump Receiving .....	10
Pump Characteristics .....	10
Equipment Serial Number .....	10
Pump Shaft Location .....	10
Dimensions .....	11
Operating Parameters .....	12
<b>Installation .....</b>	<b>13</b>
Install Pump and Drive Unit .....	13
Install Connections and Piping .....	13
Fittings .....	13
Piping Support .....	13
Expansion Joints .....	13
Inlet Piping .....	14
Changing Direction of Flow .....	14
Install Check Valves .....	14
Inlet Side on Lift Applications .....	14
Discharge Side .....	14
Install Isolation Valves .....	14
Install Relief Valves .....	15
Inlet Side Strainers and Traps .....	15
Install Pressure Gauges .....	15
Check Coupling Alignment .....	15
Check Angular Alignment .....	16
Check Parallel Alignment .....	16
Check Pump Rotation .....	16
<b>Operation .....</b>	<b>17</b>
Pre-Startup Checklist .....	17
Startup Procedure .....	17
Shutdown Procedure .....	17
Emergency Shutdown Procedure .....	17
<b>Maintenance .....</b>	<b>18</b>
Important Safety Information .....	18
Lubrication .....	18
Drive Lubrication .....	18
Gears .....	18
Bearings .....	18
Maintenance Inspections .....	19
Mechanical Seals .....	19
Gear Case .....	19
Inspection of Rotor Tips .....	19
Inspection of Rotor, Shaft Key and Keyway .....	19
Inspection of Shaft .....	19
Inspection of Gears and Bearings .....	20
Maintenance Inspection Chart .....	20

# Table of Contents

Annual Maintenance .....	21
Cleaning .....	21
Fluid Head Disassembly .....	22
Remove Cover .....	22
Remove Rotor Nut Assemblies .....	22
Remove Rotors .....	23
Remove Pump Body .....	23
Remove Mechanical Seal .....	23
Gear Case Disassembly .....	23
Remove Gear Case Cover .....	23
Remove Shaft .....	24
Replace Bearing Assemblies .....	25
Gear Case Assembly .....	27
Install Shaft .....	27
Install Rear Seal Assembly .....	29
Install Timing Gears .....	29
Install Gear Case Cover .....	29
Checking for Proper Clearance .....	30
Fluid Head Assembly .....	31
Install Mechanical Seal .....	31
Install Pump Body .....	32
Install Rotors .....	32
Install Rotor Nut Assemblies .....	32
Install Cover .....	33
<b>Parts Lists .....</b>	<b>34</b>
AP015UII Pump .....	35
AP030UII Pump .....	37
AP045UII Pump .....	39
AP060UII Pump .....	41
AP015UII Pump Seal .....	42
AP030UII Pump Seal .....	43
AP045UII Pump Seal .....	44
AP060UII Pump Seal .....	45
<b>Troubleshooting .....</b>	<b>46</b>

## **Waukesha Cherry-Burrell Warranty**

Seller warrants its products to be free from defect in materials and workmanship for a period of one (1) year from the date of shipment. This warranty shall not apply to products which require repair or replacement due to normal wear and tear or to products which are subjected to accident, misuse or improper maintenance. This warranty extends only to the original Buyer. Products manufactured by others but furnished by Seller are exempted from this warranty and are limited to the original manufacturer's warranty.

Seller's sole obligation under this warranty shall be to repair or replace any products that Seller determines, in its discretion, to be defective. Seller reserves the right either to inspect the products in the field or to request their prepaid return to Seller. Seller shall not be responsible for any transportation charges, duty, taxes, freight, labor or other costs. The cost of removing and/or installing products which have been repaired or replaced shall be at Buyer's expense.

Seller expressly disclaims all other warranties, express or implied, including without limitation any warranty of merchantability of fitness for a particular purpose. The foregoing sets forth Seller's entire and exclusive liability, and Buyer's exclusive and sole remedy, for any claim of damages in connection with the sale of products. In no event shall Seller be liable for any special consequential incidental or indirect damages (including without limitation attorney's fees and expenses), nor shall Seller be liable for any loss of profit or material arising out of or relating to the sale or operation of the products based on contract, tort (including negligence), strict liability or otherwise.

### **Shipping Damage or Loss**

If equipment is damaged or lost in transit, file a claim at once with the delivering carrier. The carrier has signed the Bill of Lading acknowledging that the shipment has been received from WCB in good condition. WCB is not responsible for the collection of claims or replacement of materials due to transit shortages or damages.

### **Warranty Claim**

Warranty claims must have a **Returned Goods Authorization (RGA)** from the Seller before returns will be accepted.

Claims for shortages or other errors, exclusive of transit shortages or damages, must be made in writing to Seller within ten (10) days after delivery. Failure to give such notice shall constitute acceptance and waiver of all such claims by Buyer.

## Safety

### READ AND UNDERSTAND THIS MANUAL PRIOR TO INSTALLING, OPERATING OR SERVICING THIS EQUIPMENT

Waukesha Cherry-Burrell recommends users of our equipment and designs follow the latest Industrial Safety Standards. At a minimum, these should include the industrial safety requirements established by:

1. Occupational Safety and Health Administration (OSHA), Title 29 of the CFR  
Section 1910.212- General Requirements for all Machines
2. National Fire Protection Association, ANSI/NFPA 79  
ANSI/NFPA 79- Electrical Standards for Industrial Machinery
3. National Electrical Code, ANSI/NFPA 70  
ANSI/NFPA 70- National Electrical Code  
ANSI/NFPA 70E- Electrical Safety Requirement for Employee Workplaces
4. American National Standards Institute, Section B11

**Attention:** Servicing energized industrial equipment can be hazardous. Severe injury or death can result from electrical shock, burn, or unintended actuation of controlled equipment. Recommended practice is to disconnect and lockout industrial equipment from power sources, and release stored energy, if present. Refer to the National Fire Protection Association Standard No. NFPA70E, Part II and (as applicable) OSHA rules for Control of Hazardous Energy Sources (Lockout-Tagout) and OSHA Electrical Safety Related Work Practices, including procedural requirements for:

- Lockout-tagout
- Personnel qualifications and training requirements
- When it is not feasible to de-energize and lockout-tagout electrical circuits and equipment before working on or near exposed circuit parts

**Locking and Interlocking Devices:** These devices should be checked for proper working condition and capability of performing their intended functions. Make replacements only with the original manufacturer's renewal parts or kits. Adjust or repair in accordance with the manufacturer's instructions.

**Periodic Inspection:** Industrial equipment should be inspected periodically. Inspection intervals should be based on environmental and operating conditions and adjusted as indicated by experience. At a minimum, an initial inspection within 3 to 4 months after installation is recommended. Inspection of the electrical control systems should meet the recommendations as specified in the National Electrical Manufacturers Association (NEMA) Standard No. ICS 1.3, Preventative Maintenance of Industrial Control and Systems Equipment, for the general guidelines for setting-up a periodic maintenance program.

**Replacement Equipment:** Use only replacement parts and devices recommended by the manufacturer to maintain the integrity of the equipment. Make sure the parts are properly matched to the equipment series, model, serial number, and revision level of the equipment.

Warnings and cautions are provided in this manual to help avoid serious injury and/or possible damage to equipment:



**DANGER:** marked with a stop sign.  
Immediate hazards which **WILL** result in severe personal injury or death.



**WARNING:** marked with a warning triangle.  
Hazards or unsafe practices which **COULD** result in severe personal injury or death.



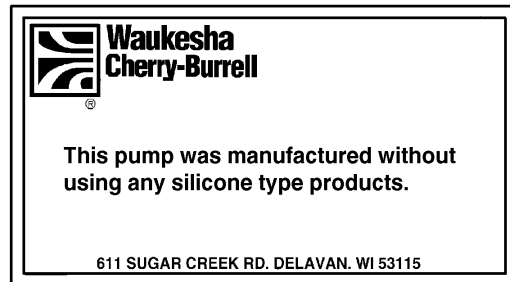
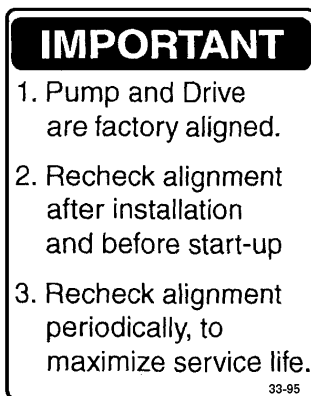
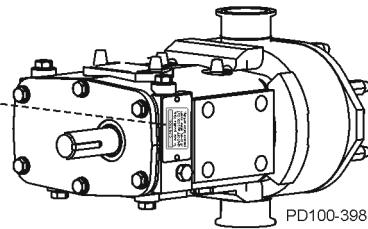
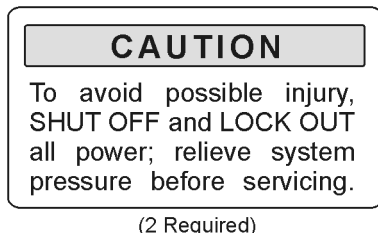
**CAUTION:** marked with a warning triangle.  
Hazards or unsafe practices which **COULD** result in minor personal injury or product or property damage.

## Replacement Labels

**!** **WARNING:** The following labels are installed on your equipment. If these labels are removed or become unreadable contact Waukesha Cherry-Burrell customer service at 1-800-252-5200 or 262-728-1900, or refer to "Parts Lists" on page 34 for replacement part numbers.

### Application Instructions

Apply to clean, dry surface. Remove backing from label, place in proper position, protect with cover sheet and burnish. (A soft rubber roller also may be used to press label into place.) Apply all labels to be readable from front of pump.





---

## Care of Stainless Steel

### Stainless Steel Corrosion

Corrosion resistance is greatest when a layer of oxide film is formed on the surface of stainless steel. If film is disturbed or destroyed, stainless steel becomes much less resistant to corrosion and may rust, pit or crack.

Corrosion pitting, rusting and stress cracks may occur due to chemical attack. Use only cleaning chemicals specified by a reputable chemical manufacturer for use with 300 series stainless steel. Do not use excessive concentrations, temperatures or exposure times. Avoid contact with highly corrosive acids such as hydrofluoric, hydrochloric or sulfuric. Also avoid prolonged contact with chloride-containing chemicals, especially in presence of acid. If chlorine-based sanitizers are used, such as sodium hypochlorite (bleach), do not exceed concentrations of 150 ppm available chlorine, do not exceed contact time of 20 minutes, and do not exceed temperatures of 104°F (40°C).

Corrosion discoloration, deposits or pitting may occur under product deposits or under gaskets. Keep surfaces clean, including those under gaskets or in grooves or tight corners. Clean immediately after use. Do not allow equipment to set idle, exposed to air with accumulated foreign material on the surface.

Corrosion pitting may occur when stray electrical currents come in contact with moist stainless steel. Ensure all electrical devices connected to the equipment are correctly grounded.

### Alloy 88

Waukesha Alloy 88 is the standard rotor material for Universal I, Universal II, Universal Lobe, Universal 420/520 and 5000 Series Rotary PD pumps. This alloy was developed specifically for corrosion resistance and close operating clearance requirements of high performance rotary positive displacement pumps. Alloy 88 is a nickel based, corrosion-resistant, non-galling or seizing material. The ASTM designation is A494 Grade CY5SnBiM (UNS N26055), and the material is listed in the 3-A Sanitary Standards as acceptable for product contact surfaces.

The above properties make Alloy 88 the ideal material for Waukesha stainless steel PD pumps. The non-galling rotors permit close operating clearances in the liquid end. This provides low slip and minimum shear damage. The rotors will not gall or seize if they come in contact with the body or cover during operation.

The corrosion resistance of Alloy 88 is approximately equal to AISI 300 Series Stainless Steel. However, Alloy 88 has limited resistance to certain aggressive chemicals that may be commonly used in contact with AISI 300 Series Stainless Steel.

Do not use Alloy 88 in contact with nitric acid. Nitric acid is commonly used to passivate new installations of stainless steel equipment. Do not allow nitric acid based passivation chemicals to contact Alloy 88 rotors. Remove the rotors during passivation and use a separate pump to circulate the passivation chemicals. Also, if nitric acid-based CIP cleaning chemicals are used, remove the rotors prior to CIP cleaning and clean them separately by hand in a mild detergent.

If you have questions regarding other aggressive chemicals, please contact Waukesha Cherry-Burrell Application Engineering for assistance.

### Elastomer Seal Replacement Following Passivation

Passivation chemicals can damage product contact areas of WCB equipment. Elastomers (rubber components) are most likely to be affected. Always inspect all elastomer seals after passivation is completed. Replace any seals showing signs of chemical attack. Indications may include swelling, cracks, loss of elasticity or any other noticeable changes when compared with new components.

## Introduction

Numerical callouts in illustrations reflect item numbers in Parts Lists beginning on page 34. Alphabetical callouts represent pre-assembled parts not found in Parts Lists.

### Pump Receiving



**DANGER:** Pump contains internal moving parts. DO NOT put hands or fingers into pump body ports or drive area at any time during operation. To avoid serious injury, DO NOT install, clean, service, or repair pump unless all power is off and locked out.

All ports are covered at the factory to keep out foreign objects during transit. If covers are missing or damaged, remove pump cover for a thorough inspection of fluid head. Be sure pumping head is clean and free of foreign material before rotating shaft.

Each Waukesha Cherry-Burrell pump is shipped completely assembled, lubricated and ready for use. Review "Operation" on page 17 before operating pump.

### Equipment Serial Number

All Waukesha Cherry-Burrell pumps are identified by a serial number on gear case nameplate, which also is stamped on pump body and cover. **Gear case, body and cover must be kept together as a unit due to backface, rotor and cover clearance. Failure to do so will damage pump.**

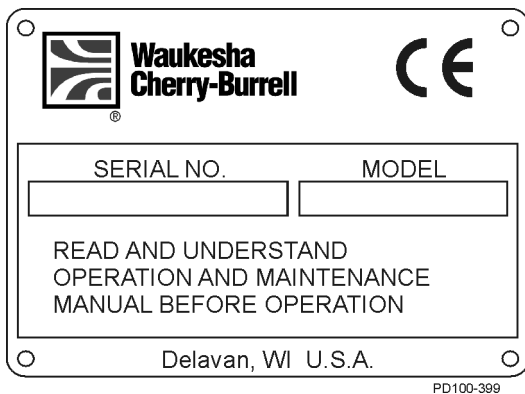


Figure 1 - Gear Case Nameplate

### Pump Characteristics

Waukesha Cherry-Burrell AP-UII pumps are positive displacement, low slip, stainless steel pumps designed with larger diameter shafts for greater strength and stiffness, mounted on a heavy duty cast iron bearing frame with double tapered roller bearings.

- Silicone free.
- Designed for continuous operation.
- Pump body suction-vented to enhance seal performance.
- Rotor connections sealed from product zone.
- Rotors secured to shafts using rotor nuts supplied with belleville washers.
- Non-galling "88" alloy rotors standard.
- Single mechanical seals standard.

### Pump Shaft Location

There are two pump drive shaft locations.

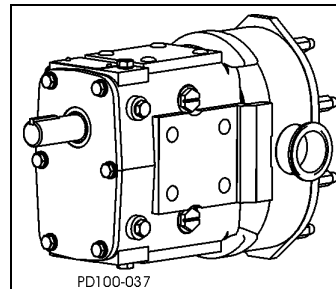


Figure 2 - Upper Shaft Mount

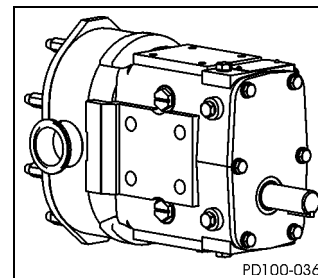
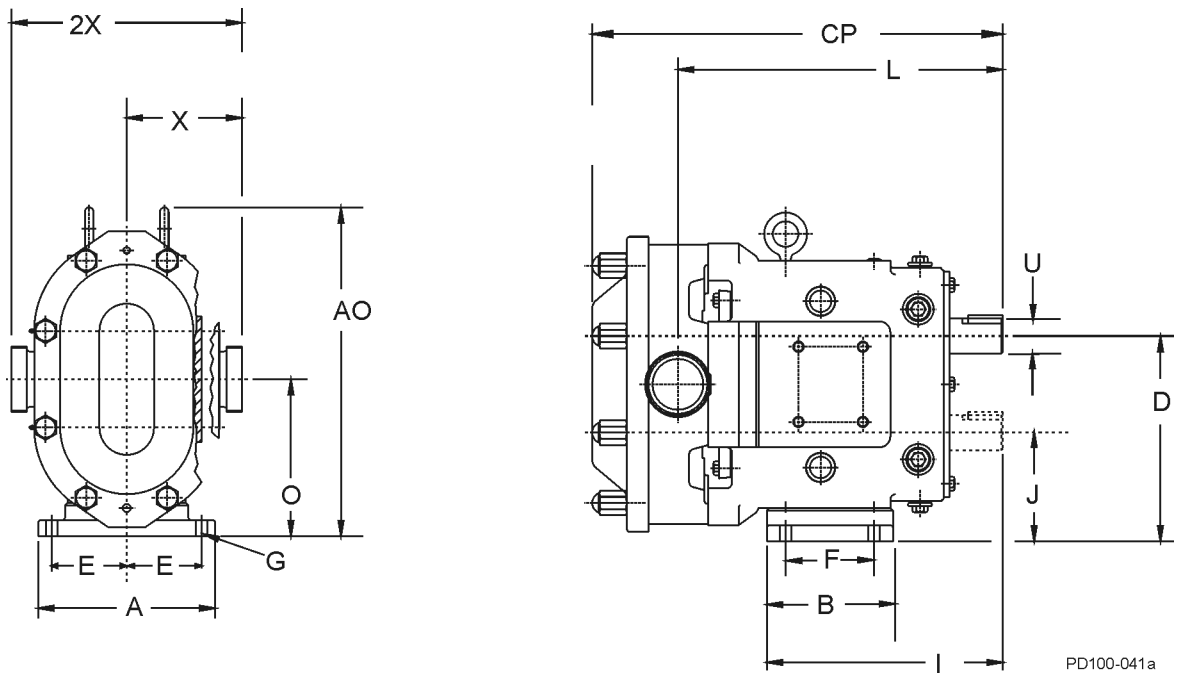


Figure 3 - Lower Shaft Mount

**Dimensions**



ITEM	AP015UII		AP030UII		AP045UII		AP060UII	
	in	mm	in	mm	in	mm	in	mm
A	4.75	121	6.25	159	8.25	210	8.25	210
AO	8.30	211	10.29	261	15.31	389	15.31	389
B	3.75	95	4.25	108	5.87	149	5.87	149
CP	11.71	297	14.49	368	18.59	472	19.14	486
D	5.50	140	6.86	396	9.56	243	9.56	243
E	1.94	49	2.31	59	3.50	89	3.50	89
F	2.13	59	2.56	65	4.12	105	4.12	105
G	.41, slot	10, slot	.41, slot	10, slot	.53, slot	13, slot	.53, slot	13, slot
I	7.66	194	8.83	224	10.99	279	10.99	279
J	2.93	74	3.56	90	5.06	129	5.06	129
L	9.61	244	11.61	295	14.68	377	15.14	385
O	4.21	107	5.12	132	7.31	186	7.31	186
U	.875	22.23	1.25	31.75	1.625	41.28	1.625	41.28
X	3.49	89	4.25	108	5.37	136	5.37	136
2X	6.97	177	8.50	216	10.75	273	10.75	273
Pump Weight	52 lbs	24 kg	100 lbs	45 kg	225 lbs	102 kg	255 lbs	115 kg

**Operating Parameters**

MODEL	DISPLACEMENT PER REVOLUTION	NOMINAL CAPACITY TO*	INLET/ OUTLET	OPTIONAL INLET/ OUTLET	MAXIMUM PRESSURE RATING*	MAXIMUM RPM*	TEMP RANGE
AP015UII	0.142 gal (0.054 liter)	11 gpm (2.5 m <sup>3</sup> /hr)	1-1/2"	-	250 psi (17.2 bar)	800	-40°F (-40°C) to 180°F (82°C)
AP030UII	0.060 gal (0.227 liter)	36 gpm (8.2 m <sup>3</sup> /hr)	1-1/2"	2"	250 psi (17.2 bar)	600	
AP045UII	0.098 gal (0.371 liter)	58 gpm (13.2 m <sup>3</sup> /hr)	2"	-	450 psi (31.0 bar)	600	
AP060UII	0.153 gal (0.579 liter)	90 gpm (20.4 m <sup>3</sup> /hr)	2-1/2"	3"	300 psi (20.7 bar)	600	

*\*Actual operating conditions vary with each application. In consideration of wear life, most applications are limited to significantly lower operating speeds and flow rates. Consult WCB Application Engineering.*

## Installation

Installation of pump and piping system should be in accordance with local codes and restrictions. Practices described in this manual are recommended for optimum performance.

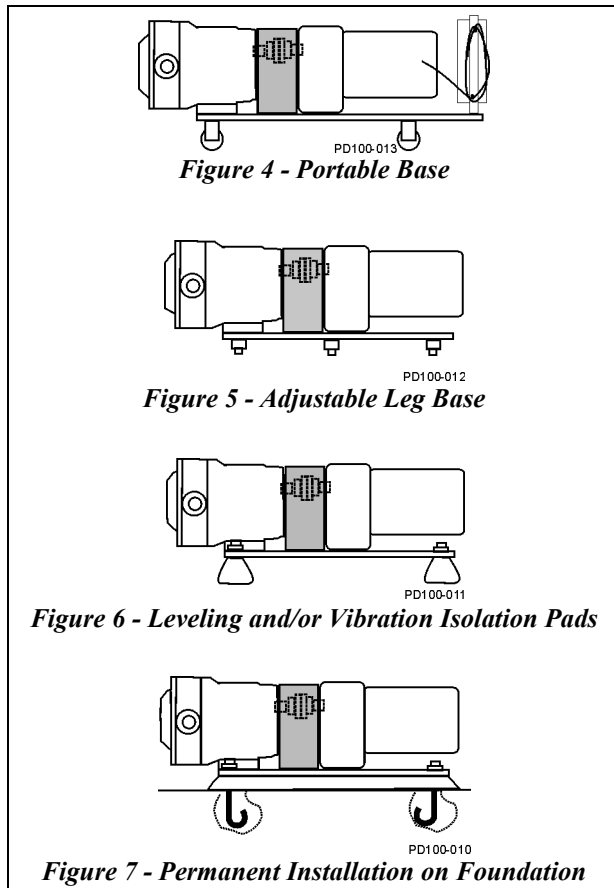
All system equipment, such as motors, sheaves, drive couplings, speed reducers, etc., must be properly sized to insure satisfactory operation of your Waukesha Cherry-Burrell pump within its limits.

**CAUTION:** These pumps are positive displacement, low slip design and will be severely damaged if operated with closed valves in discharge or inlet lines. Pump warranty is not valid for damages caused by a hydraulic overload from operation or start-up with a closed valve in the system.

### Install Pump and Drive Unit

**WARNING:** Full guards must be installed to isolate operators and maintenance personnel from rotating components. Guards are provided with Waukesha Cherry-Burrell pumps as part of a complete pump and drive package.

Typical installation configuration is mounting pump and drive unit on common base plate. Unit can be installed in any of the following ways: (shaded area indicates guard location)



**NOTE:** When installing unit as shown in Figure 7, unit must be leveled before installation on bolts.

### Install Connections and Piping

#### Fittings

Waukesha Cherry-Burrell produces a wide variety of fittings made to fit your needs. Contact Waukesha Cherry-Burrell Customer Service at 1-800-252-5200 or 262-728-1900 for information on fittings.

#### Piping Support

All piping to pump should be supported independently with hangers or pedestals minimizing forces exerted on pump. Such forces can cause misalignment of pump parts and lead to excessive wear of rotors, bearings and shafts.

Figure 8 shows typical supporting methods used to independently support each pipe reducing weight effect of piping and fluid on pump.

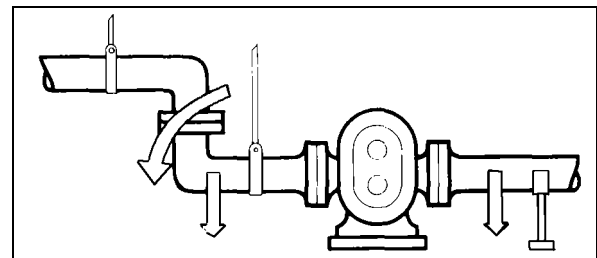


Figure 8 - Piping Support

#### Expansion Joints

Thermal expansion of piping can cause tremendous forces. Use thermal expansion joints to minimize forces on pump.

Flexible joints can be used to limit transmission of mechanical vibration. Ensure free ends of any flexible connections in system are anchored.

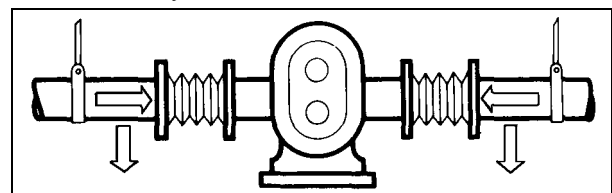


Figure 9 - Flexible Connections and Supports

## Inlet Piping

Install pump below supply liquid level to reduce air in system by flooded suction (Figure 10).

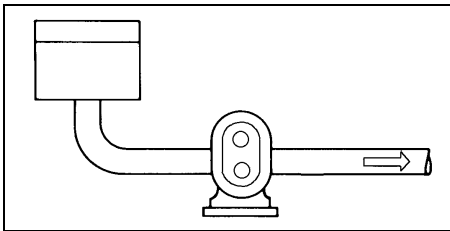


Figure 10 - Pump Below Supply

If pump is installed above supply liquid level, piping on inlet side must slope up toward pump preventing air pockets in pipes (Figure 11).

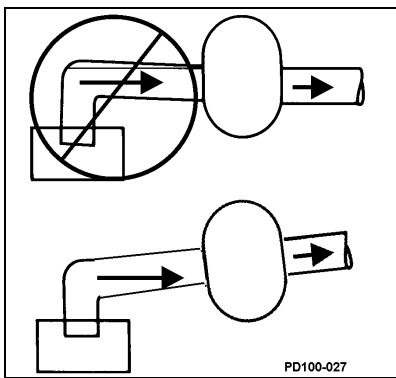


Figure 11 - Correct Piping to Prevent Inlet Air Pockets

## Changing Direction of Flow

**NOTE:** All AP model pumps manufactured after January 1, 2003 are designed with dedicated and marked inlet and discharge ports. Pumps with “INLET” and “DISCHARGE” stamped into casing have been fitted with internal suction vents.

Body orientation is maintained with two interchangeable dowel pin bushings press fitted into gearcase. To reverse direction of flow through pump, dowel pin bushings must be removed and installed in opposite orientation. Various mechanical or hydraulic methods can be used to remove bushings from gearcase.



**CAUTION:** Replace dowel pin bushings if damaged during removal. Do not damage gearcase during removal process.

**NOTE:** Check all running clearances between rotor and body after reassembling pump and establishing new flow direction.

## Install Check Valves

### Inlet Side on Lift Applications

Use check valves to keep inlet line full, particularly with low viscosity fluids (Figure 12).

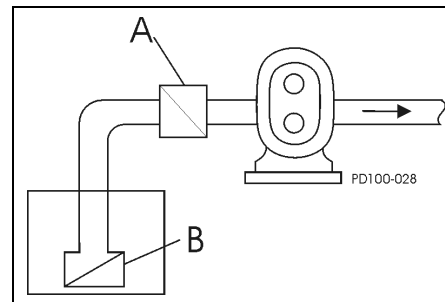


Figure 12 - Inlet Check Valve

- A. Inlet Check Valve
- B. Foot Check Valve

### Discharge Side

For systems with liquid under a vacuum, a check valve on discharge side of pump is recommended. Check valve prevents backflow (air or fluid) to aid in initial start-up by minimizing required differential pressure supplied by pump to start flow (Figure 13).

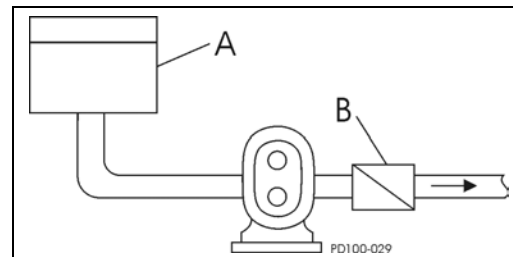


Figure 13 - Discharge Check Valve

- A. Closed Tank - produces vacuum on liquid (Low Absolute Pressure)
- B. Check Valve (outlet)

## Install Isolation Valves

Isolation valves permit pump maintenance and safe pump removal without draining system (Figure 14, item A).

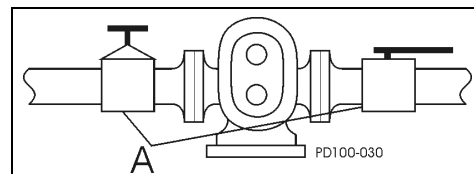
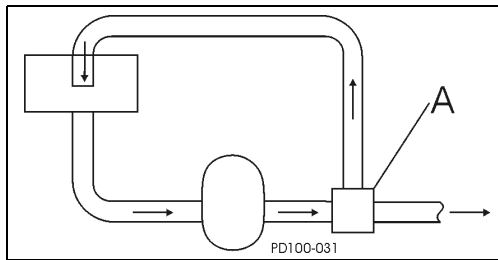


Figure 14 - Isolation Valves

## Install Relief Valves

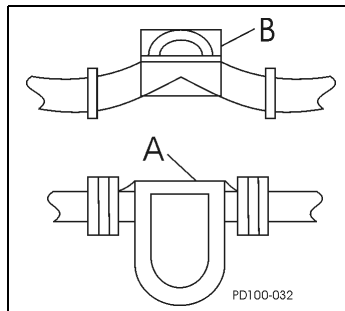
Install relief valves to protect pump and piping system against excessive pressure. An external relief valve designed to bypass fluid from pump outlet to inlet side of system is recommended (Figure 15, item A).



**Figure 15 - Relief Valves**

## Inlet Side Strainers and Traps

Inlet side strainers and traps (Figure 16, items A and B) can be used to prevent foreign matter from damaging pump. Selection must be carefully made to prevent restriction of inlet causing cavitation. If inlet strainers are used, they must be serviced regularly to prevent clogging and flow stoppage.



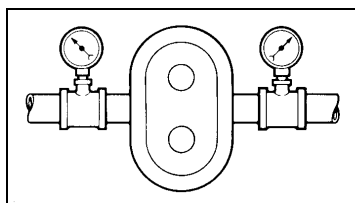
**Figure 16 - Inline Strainers and Traps**

- A. Strainer
- B. Magnetic Trap

## Install Pressure Gauges

Pressure and vacuum gauges provide valuable information about pump operation (Figure 17). Wherever possible, install gauges to help provide information on the following:

- Normal or abnormal pressures
- Indication of flow
- Changes in pump condition
- Changes in system conditions
- Changes in fluid viscosity



**Figure 17 - Pressure and Vacuum Gauges**

## Check Coupling Alignment

Pumps and drives ordered from factory and mounted on a common base plate are aligned before shipment. Alignment **must** be rechecked after complete unit has been installed and piping completed. Periodic rechecking is advisable during pump service life.

- Using flexible coupling connecting drive to pump is recommended. Several different types are available, including couplings with slip or overload provision. Waukesha Cherry-Burrell provides Lovejoy (Figure 18) or T.B. Woods® (Figure 19) couplings unless otherwise specified when ordering. Flexible coupling can be used to compensate for end play and small differences in alignment.

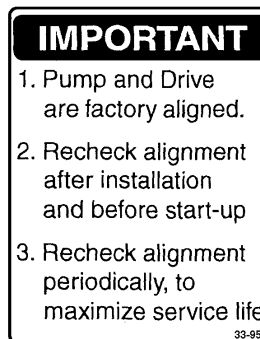


**Figure 18 - Lovejoy Coupling**



**Figure 19 - T.B. Woods® Coupling**

- Align pump and drive shaft as closely as possible.



**Figure 20 - Alignment Sticker**

## Check Angular Alignment

1. Using feeler gauges or taper gauges (Figure 21, items A and B), check alignment at four points every 90 degrees around coupling; **adjust to equal dimension at all points.**
2. Set space between coupling halves to manufacturer's recommended distance.
3. Install shims to bring system into alignment.

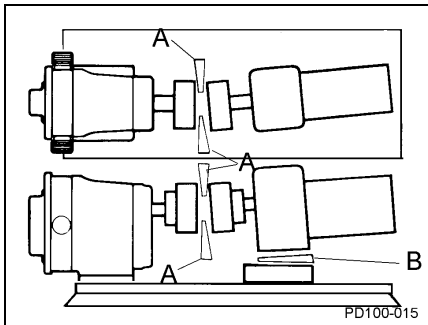


Figure 21 - Check Angular Alignment

## Check Parallel Alignment

1. Check both horizontal and vertical alignment of pump and drive using straight edge.
2. Using feeler gauge at location "A" in Figure 22, determine direction and amount of movement needed (Figure 22, item B).
3. If necessary, shim at location "C" and/or move drive as needed.

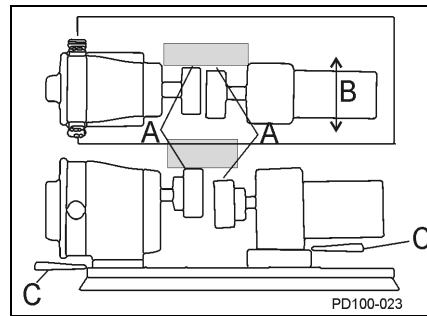


Figure 22 - Check Parallel Alignment

## Check Pump Rotation

Check rotation direction of drive to determine rotation direction of pump (Figure 23 and Figure 24). After correct drive rotation is verified, connect coupling and assemble pump and coupling guards.

**NOTE:** Pump covers in the following figures have been removed to view rotor rotation. **Pump must never be operated with covers removed.**

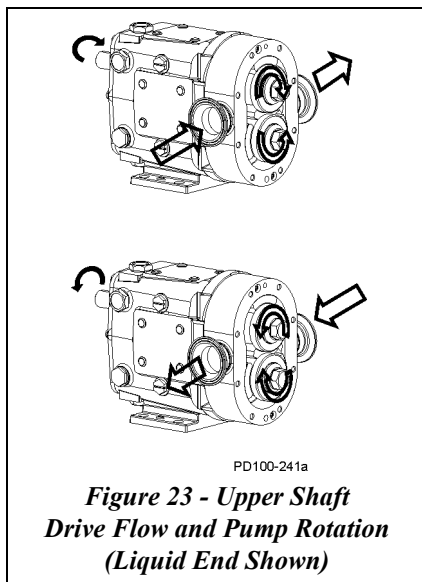


Figure 23 - Upper Shaft  
Drive Flow and Pump Rotation  
(Liquid End Shown)

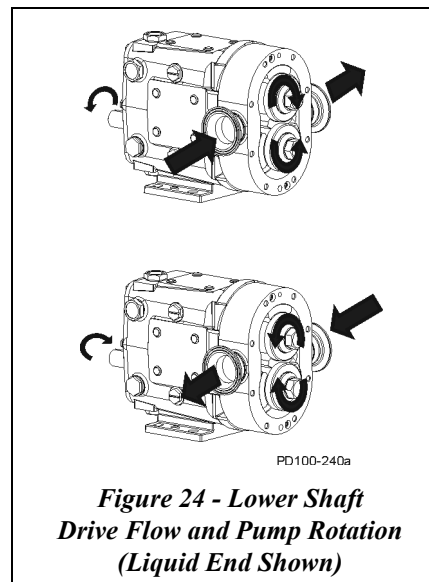


Figure 24 - Lower Shaft  
Drive Flow and Pump Rotation  
(Liquid End Shown)



## Operation



**DANGER:** Pump contains internal moving parts. **DO NOT** put hands or fingers into pump body ports or drive area at any time during operation. To avoid serious injury, **DO NOT** install, clean, service or repair pump unless all power is off and locked out.



**CAUTION:** These pumps are positive displacement, low slip design and will be severely damaged if operated with closed valves in discharge or inlet lines. Pump warranty is not valid for damages caused by a hydraulic overload from operation or start-up with a closed valve in the system.

### Pre-Startup Checklist

1. Ensure pump is correctly installed as described in “Installation” on page 13. Review “Install Relief Valves” on page 15 and install relief valves as needed.
2. Check coupling alignment. See “Check Coupling Alignment” on page 15.
3. Ensure pump and piping are clean and free of foreign material such as welding slag, gaskets, etc.



**CAUTION:** Do not use this pump to flush newly installed system. Severe damage may occur to pump and system if pump is used to flush system. Rotors should be removed during system flushing.

4. Ensure all piping connections are tight and leak-free. Where possible, check system with non-hazardous fluid.
5. Ensure pump and drive are lubricated. See “Lubrication” on page 18.

6. Ensure all guards are in place and secure.



**WARNING:** Full guards must be installed to isolate operators and maintenance personnel from rotating components. Guards are provided with Waukesha Cherry-Burrell pumps as part of a complete pump and drive package.

7. Ensure all valves are open on discharge side and a free flow path is open to destination.
8. Ensure all valves are open on inlet side and fluid can fill pump. A flooded suction installation is recommended.
9. Check direction of pump and drive rotation to ensure pump will rotate in proper direction. See “Check Pump Rotation” on page 16.

### Startup Procedure

1. Start pump drive. Where possible start at slow speed or jog.
2. Ensure liquid is reaching pump within 60 seconds. If pumping does not begin and stabilize, check “Troubleshooting” on page 46.

### Shutdown Procedure

1. Shut off power to pump drive.
2. Shut off supply and discharge lines.

### Emergency Shutdown Procedure

Emergency Shutdown Procedures should be documented by plant personnel after assessing system-wide requirements.

**Maintenance**

**Important Safety Information**



**DANGER:** Pump contains internal moving parts. DO NOT put hands or fingers into pump body ports or drive area at any time during operation. To avoid serious injury, DO NOT install, clean, service or repair pump unless all power is off and locked out.

Before detaching port connections to pump:

- Close suction and discharge valves.
- Drain pump and clean or rinse, if necessary.
- Disconnect or shut off electrical supply and lock out all power.

**Lubrication**

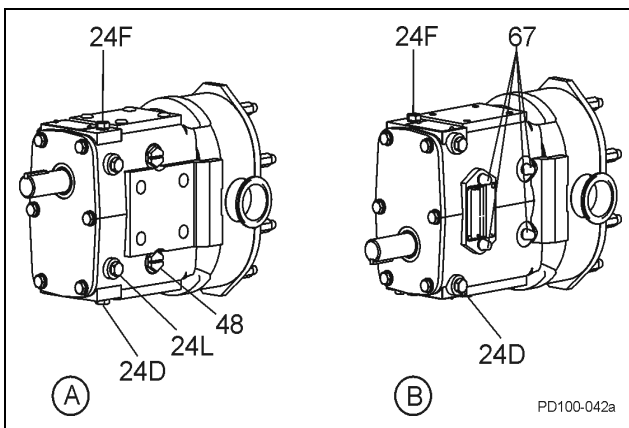


Figure 25 - Lubrication Points

A. Upper Shaft Drive Pump (Standard)
B. Lower Shaft Drive Pump (Optional)
24D. Oil Drain
24F. Oil Fill Plug
24L. Oil Level Check Plug
48. Grease Clean-out Plug
67. Grease Fittings

**Drive Lubrication**

Refer to manufacturer’s manual shipped with drive for proper drive lubrication and frequency.

**Gears**

Gears are factory lubricated with gear oil at quantity shown. **Change oil every other month.**

MODEL	OIL CAPACITY (GEARS)	
	AP015UII	1.3 oz
AP030UII	2.0 oz	60 ml
AP045UII AP060UII	6.0 oz	170 ml

***Gear Oil Specification***

ISO Grade 320, SAE 140 or AGMA Number 6EP can be ordered through your local representative with WCB part number 118402, sold in one-gallon (U.S.) containers.

**Bearings**

Bearings are factory lubricated with grease at quantity shown. **Grease bearings monthly.**

**Excess grease will accumulate in gear case and must be removed through cleanout hole covered with plastic plug.**

MODEL	LOCATION	GREASE QUANTITY (PER BEARING)	
		AP015UII	Front
	Back	0.61 oz	18 cc
AP030UII	Front	1.01 oz	30 cc
	Back	0.85 oz	25 cc
AP045UII AP060UII	Front	2.37 oz	70 cc
	Back	1.52 oz	45 cc

***Bearing Lubricant Grease***

NLGI Grade 2 lithium-based lubricant can be ordered through your local representative with WCB part number 118401, sold in 14 ounce, 2-inch diameter tubes.

## Maintenance Inspections



**DANGER:** Pump contains internal moving parts. DO NOT put hands or fingers into pump body ports or drive area at any time during operation. To avoid serious injury, DO NOT install, clean, service or repair pump unless all power is off and locked out.

Detecting wear in the early stages can reduce repair costs and down time. A simple “look-feel” inspection of pump during breakdown cleaning is recommended to detect signs of trouble at an early stage.

A detailed maintenance inspection should be scheduled annually. See “Annual Maintenance” on page 21.

### Mechanical Seals

Pumps can be supplied with either single mechanical seals or double mechanical seals.

If single seals were supplied, they should be visually inspected for any signs of leakage. If leakage is detected, the outside of seal may be wiped clean with solvent while pump is running. If leakage continues, pump liquid end should be disassembled, and seals cleaned and inspected. Replace seals if chipped, cracked or scratched. If seals are allowed to continue to leak, pumped product may get into gear case and destroy bearings and liquid end clearances in pump.

If double seals were supplied, ensure that flush liquid system is installed and flush liquid is between inner seal and outer seal. If outer seal is leaking, pump liquid end should be disassembled, and seals cleaned, inspected and replaced if necessary. Contact your local distributor or factory if you have any questions on your double seal flush system.

### Gear Case

The gear case is fitted with two plastic screw-in clean out plugs. The lower plug should be removed, and gear case inspected for excess grease or contamination from water or product being pumped. Water or other contamination can lead to early bearing failure and damaged pump liquid end clearances.

### Inspection of Rotor Tips

With cover removed, check for metal-to-metal contact between rotor wings. When contact is detected, pump should be repaired or replaced.

Visually inspect rotors for rotor tip to rotor tip contact and rotor tip to rotor hub contact. Manually rotate pump drive

shaft and ensure rotor tip clearance is equal on both sides as indicated in Figure 26.

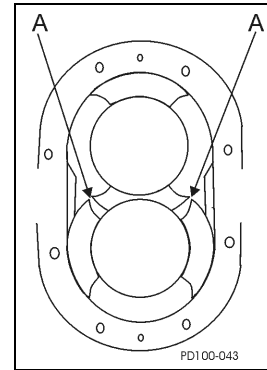


Figure 26 - Rotor to Rotor Tip Clearance

### Inspection of Rotor, Shaft Key and Keyway

Visually inspect rotor, shaft key and rotor keyway (Figure 27, item A) for excessive wear; replace as necessary.

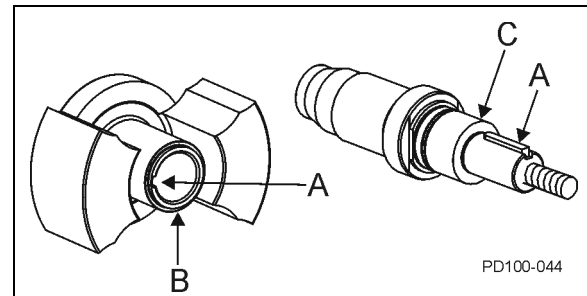


Figure 27 - Rotor and Shaft Inspection

### Inspection of Shaft

Visually inspect shaft for twists or bends; replace as necessary.

## Inspection of Gears and Bearings

With fluid head and seals removed, feel for gear backlash by rotating (by hand) either shaft. The other shaft must engage immediately. Perform check 3 times at 60-degree intervals. If play (backlash) is evident, remove gear case cover, check gear teeth for wear and ensure gear is not loose on shaft. If gear teeth are worn, replace gears. If gear is loose on shaft, inspect shaft key and keyway; replace as necessary.

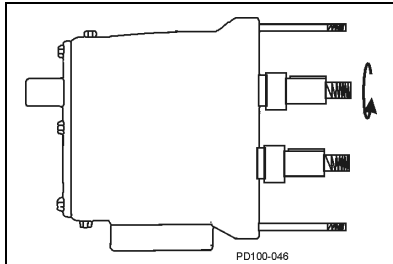


Figure 28 - Backlash Check

With fluid head and seals removed, check bearing condition by applying (by hand) an up or down force of approximately 30 lbs (14 kg). If movement is felt, bearing may be failing. Also check shaft movement forward or backward. When bearing is determined to be failing, replace bearing and review lubrication schedule.

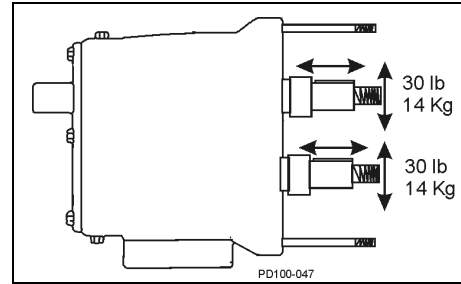


Figure 29 - Bearing Deflection Check

## Maintenance Inspection Chart

PROBLEM	POSSIBLE CAUSES	POSSIBLE SOLUTIONS
Rotor tip to rotor tip contact or uneven rotor tip to rotor tip clearance.	Hard object jammed rotors and twisted shafts.	Replace shafts. Install strainers if necessary. Check and replace gears if necessary.
Rotor tip to rotor hub contact.	Loose rotor nut(s). Belleville washer(s) on backwards. Backface clearances not even. Bearings need replacing.	Torque rotor nut(s) properly. Install belleville washers correctly. Verify backface clearances are even. Check and replace bearings.
Worn rotor or shaft keyway(s). Worn or damaged rotor key(s).	Loose rotor nut(s). Belleville washer(s) on backwards.	Replace rotors, shafts and keys. Torque rotor nut(s). Install belleville washer(s) correctly.
Gear backlash.	Lack of lubrication. Excessive hydraulic loads. Loose gear locknuts.	Check lubrication level and frequency. Reduce hydraulic loads. Torque locknuts to specified torque values. Check and replace gears if necessary.
Worn or broken gear teeth.	Lack of lubrication. Excessive hydraulic loads. Loose gear locknuts.	Check lubrication level and frequency. Reduce hydraulic loads. Torque locknuts to specified torque values. Check and replace gears if necessary.
Loose gears.	Gear locknuts not torqued properly.	Torque gear nut to specified torque value. Check and replace gears if necessary. Inspect and replace gear key, shaft keyway and shaft if necessary.
Loose bearings, axially or radially.	Lack of lubrication. Excessive hydraulic loads. Product or water contamination.	Check lubrication level and frequency. Reduce hydraulic loads. Ensure no excess grease build-up. Replace bearings if necessary.
Damaged front grease seals.	Seal may be old and worn. No grease on lips to lubricate. Shaft worn under seals.	Replace seals. Properly lubricate with grease when installing. Inspect shaft surface under seals.
Damaged rear oil seals.	Seal may be old and worn. No grease on lips to lubricate. Shaft worn under seals. Not centered on shaft when installed.	Replace seals. Properly lubricate with grease when installing. Inspect shaft surface under seals.
Leaking mechanical seals.	Chipped, scratched or cracked seal faces. Excessive pressure spikes. Seals run dry.	Replace seals. Review system. Review system or install double seals.

## Annual Maintenance

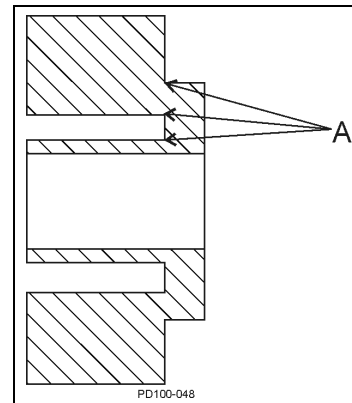


**DANGER:** Pump contains internal moving parts. DO NOT put hands or fingers into pump body ports or drive area at any time during operation. To avoid serious injury, DO NOT install, clean, service, or repair pump unless all power is off and locked out.

Procedures and corrective measures outlined in “Maintenance Inspections” on page 19 should be performed at least annually, in addition to the following preventive maintenance:

- Check bearings with dial indicator for shaft radial play. If deflection is equal to or greater than rotor-to-body diametrical clearance (“Checking for Proper Clearance” on page 30), replace bearings.
- Remove gear cover and inspect gears for wear, backlash and looseness. Loosen and torque gear retaining nuts to proper torque.
- Thoroughly inspect rotors for worn keyways, and stress cracks (Figure 30, item A). Use dye check method to detect any fatigue-type cracks at rotor stress points.
- Review performance record on pump, and check radial and backface clearances to determine wear and

effect on performance. Adjustment to operating speed can compensate for wear in some applications.



**Figure 30 - Rotor Stress Points**



**CAUTION:** When bearings or shafts are replaced in the field, care must be taken to correctly position shaft by shimming to maintain sufficient running clearances between rotor wing faces and pump body faces (backface and cover face). **It is important to hold the same backface dimension for both rotors to avoid crossover interference.**

## Cleaning

Pump cleaning schedule should be determined on site for materials being processed and plant maintenance schedule.

To disassemble fluid head, see “Fluid Head Disassembly” on page 22. Remove and clean cover o-ring, pump seals and rotor nut assembly. Inspect and replace as necessary.

**NOTE:** Rotor nut o-rings and rotor hub o-rings should always be replaced when reassembling pump after cleaning.

In applications where material can harden in pump during shutdown, flush or disassembly of fluid head and manual cleaning is strongly recommended.

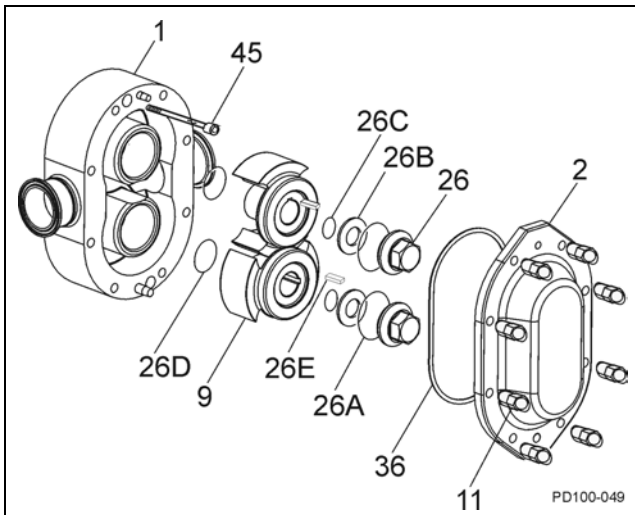
## Fluid Head Disassembly



**DANGER:** Pump contains internal moving parts. DO NOT put hands or fingers into pump body ports or drive area at any time during operation. To avoid serious injury, DO NOT install, clean, service, or repair pump unless all power is off and locked out.



**DANGER:** To avoid serious injury, shut off and drain product from pump prior to disconnecting piping.



**Figure 31 - Exploded View of Fluid Head**

1. Body	26B. Belleville Washer
2. Cover	26C. Retainer O-ring
9. Rotor	26D. Rotor Hub O-ring*
11. Cover Nut	26E. Rotor Key
26. Rotor Nut	36. Cover O-ring
26A. Rotor Nut O-ring*	45. Body Retaining Cap Screw

\*Discard rotor hub and rotor nut o-rings; one-time use only.

### Remove Cover

1. Remove cover nuts (Figure 31, item 11) from cover (Figure 31, item 1).
2. Using a soft hammer, tap cover (Figure 31, item 2) off body studs and dowel pins.
3. Place cover on a protected surface with finished surfaces up.
4. Remove and inspect cover o-ring (Figure 31, item 36).

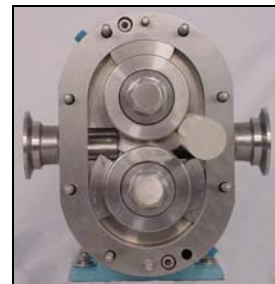
### Remove Rotor Nut Assemblies

1. Use blocking dowel to keep rotors from turning when removing rotor nuts. Always use dowel to block rotor against body, not against other rotor. See Figure 32 through Figure 34.

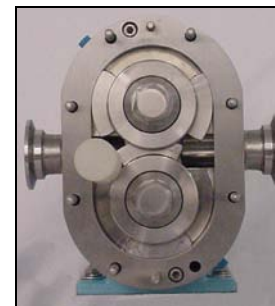


**Figure 32 - Blocking Dowel**

BLOCKING DOWELS		
MODEL	DOWEL DIAMETER	
AP015UII	3/4 in	19 mm
AP030UII	1.0 in	25 mm
AP045UII AP060UII	1-1/2 in	38 mm



**Figure 33 - Loosening Top Rotor**

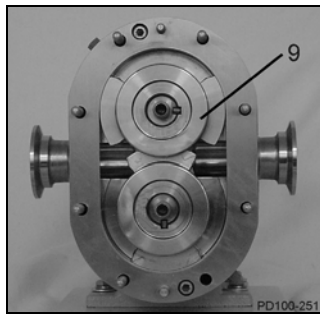


**Figure 34 - Loosening Bottom Rotor**

2. Using a wrench, remove rotor nuts, belleville washers, rotor nut o-rings and rotor hub o-rings. DO NOT use torque wrench to remove rotor nuts.

## Remove Rotors

- Using only your hands, first remove rotor with hub overlapping other rotor wing (Figure 35, item 9). Place rotors in up-turned cover to prevent damage to close tolerance parts.



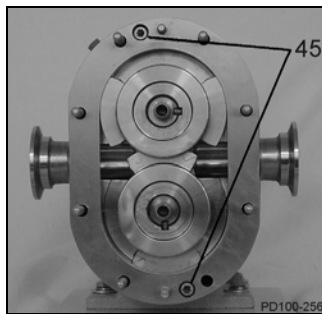
**Figure 35 - Remove Overlapping Rotor First**

If rotors cannot be removed by hand:

- Use plastic or hardwood dowels to pry out rotors.
- Remove body retaining cap screws. Tap body forward and backward with soft hammer to loosen rotors.
- If necessary, use a puller. Use care with puller or dowels to avoid damaging rotors.

## Remove Pump Body

- Remove two body retaining cap screws (Figure 36, item 45).



**Figure 36 - Location of Cap Screws**

- Using plastic mallet, tap body off gear case, dowel pins and body studs.
- Slide body straight off body studs to prevent damaging mechanical seal parts.
- Place body on protected surface with seals up to protect seals.

## Remove Mechanical Seal

- Remove rotating seal seats and shaft o-rings.
- Apply even pressure to both sides on back of seal seats when removing.

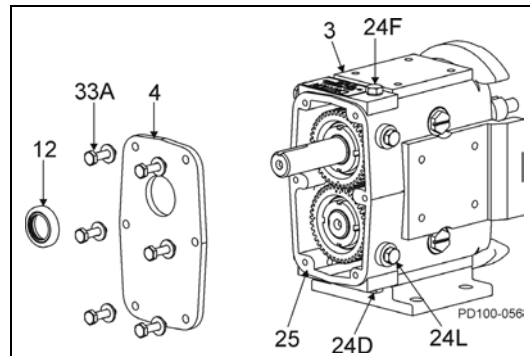
## Gear Case Disassembly



**DANGER:** To avoid serious injury, DO NOT install, clean, service, or repair pump unless all power is off and locked out.



**DANGER:** To avoid serious injury, shut off and drain product from pump prior to disconnecting piping.

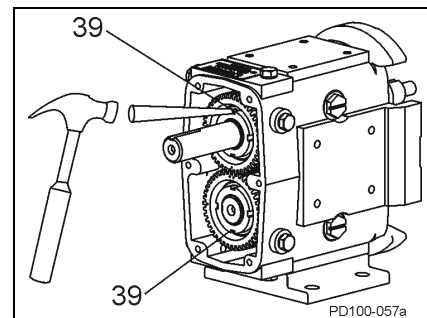


**Figure 37 - Remove Gear Case Cover**

3. Gear Case	24F. Oil Fill Plug
4. Gear Case Cover	24L. Oil Level Plug
12. Oil Seal	25. Gore-Tex <sup>®</sup> Tape
24D. Oil Drain Plug	33A. Cap Screw

## Remove Gear Case Cover

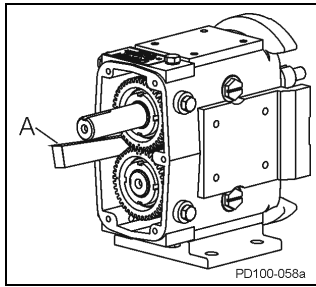
- Remove oil drain plug (Figure 37, item 24D); drain oil.
- Remove cap screws from gear case (item 33A).
- Pull cover (item 4) off shaft extension. If cover sticks, use soft hammer to loosen.
- Remove Gore-Tex<sup>®</sup> sealing tape (item 25) from gear case and cover.
- Remove oil seal (item 12) from cover using arbor press. Discard used oil seal.
- Straighten lock tab on lock washers (Figure 38, item 39).



**Figure 38 - Straighten Lock Tab on Lock Washers**

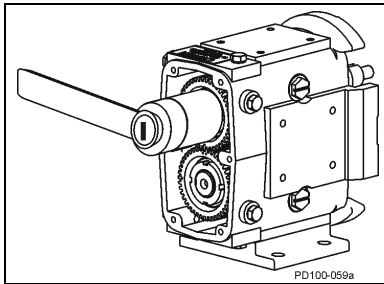
## Remove Shaft

1. Wedge a wooden block, nylon dowel or rag (Figure 39, item A) between gears to prevent shafts from turning during gear locknut removal.



**Figure 39 - Block Shaft Rotation**

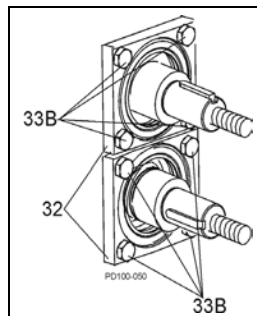
2. Using a Waukesha Cherry-Burrell Gear Locknut Tool, remove gear locknuts and lock washers. **DO NOT** remove gears at this time. For proper Gear Locknut Tool, see Parts Lists beginning on on page 34.



**Figure 40 - Remove Gear Locknuts**

**NOTE:** A spanner wrench or drift can also be used to remove gear locknuts.

3. Remove front bearing retainer bolts (Figure 41, item 33B) and pull off bearing retainers (item 32). (Stuck retainers will press out when shaft is removed.)

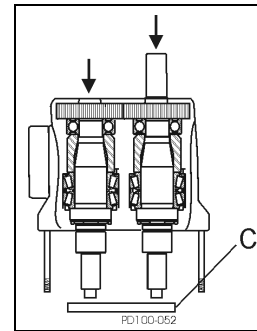


**Figure 41 - Remove Bearing Retainers**

4. Remove Gore-Tex<sup>®</sup> sealing tape from bearing retainer and gear case.

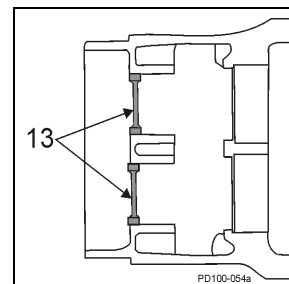
**NOTE:** Protect liquid end of shafts by wrapping with tape.

5. Place gear case on arbor press with liquid end down. Protect shaft ends with wood or plastic block (Figure 42, item C) and press shafts out of gear case.



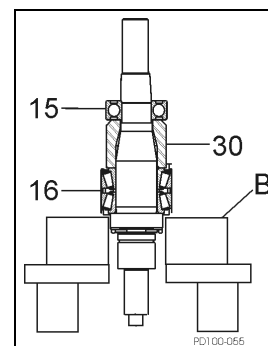
**Figure 42 - Press Shafts from Gear Case**

6. Remove gear spacers and gear keys from shafts.
7. Remove gears from gear case.
8. Press out and discard front bearing seals from front bearing retainers. Clean and reuse bearing isolators, if installed.
9. Remove shims. If shafts and bearings are reused, identify shims and bearings with each shaft.
10. Press out and discard both rear oil seals in gear case (Figure 43, item 13).



**Figure 43 - Remove Rear Oil Seals**

11. Use hydraulic press and V-blocks (Figure 44, item B) to remove bearings (items 15 and 16) and spacer (item 30).



**Figure 44 - Remove Bearings From Shaft**

**NOTE:** Make sure both ends of shaft are protected when removing shaft.

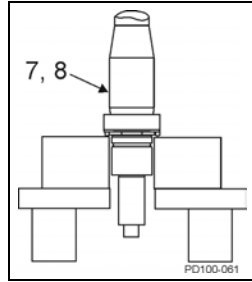


## Replace Bearing Assemblies

### Front Bearing Assembly

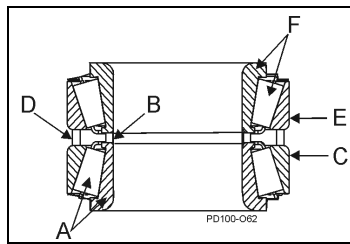
**NOTE:** The following instructions cover assembly of a six piece front bearing assembly. For a four piece assembly, only one spacer and cup is used.

1. Lubricate front bearing area of shaft (Figure 45, item 7, 8) with oil or grease. Place upright in hydraulic press with liquid end down.



**Figure 45 - Grease Shaft**

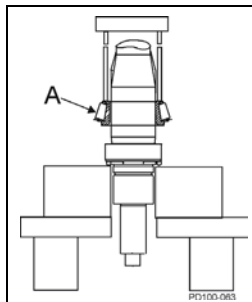
2. Unwrap front bearing assembly. **DO NOT** interchange parts of one bearing assembly with another. Parts are precisely matched during manufacturing and must be installed as a matched assembly.



**Figure 46 - Bearing Assembly**

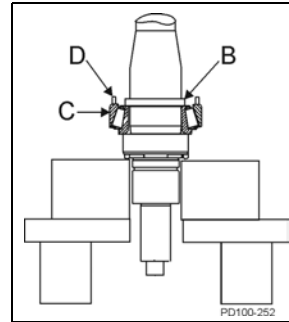
A. Lower Cone and Roller Assembly	D. Outer Spacer
B. Inner Spacer	E. Upper Cup
C. Lower Cup	F. Upper Cone and Roller Assembly

3. Lift lower cone and roller assembly (Figure 47, item A) out of bearing stack and place on shaft with radius down. Press onto shaft until seated against shaft shoulder. **Press only on inner cone.**



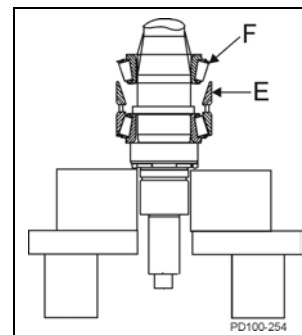
**Figure 47 - Press Lower Cone and Roller Assembly onto Shaft**

4. Place inner spacer (Figure 48, item B) over shaft onto lower cone and roller assembly.
5. Place lower cup (item C) over lower cone and roller assembly, keeping cup opening toward assembly.
6. Place outer spacer (item D) over shaft and onto lower cup.



**Figure 48 - Install Inner & Outer Spacer and Lower Cup**

7. Place upper cup (Figure 49, item E) on top of outer spacer.

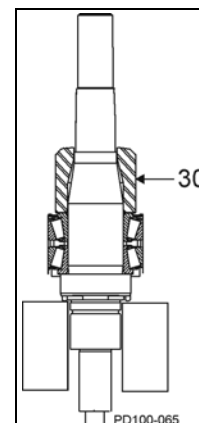


**Figure 49 - Install Upper Cup & Upper Cone**

8. Lubricate remaining upper cone and roller assembly (Figure 49, item F) with oil or grease and slip over shaft with roller radius up. Press onto shaft and into upper cup.

**NOTE:** Make sure all components are aligned before pressing. **Press only on inner cone.**

9. Install bearing spacer (Figure 50, item 30).



**Figure 50 - Install Bearing Spacer**

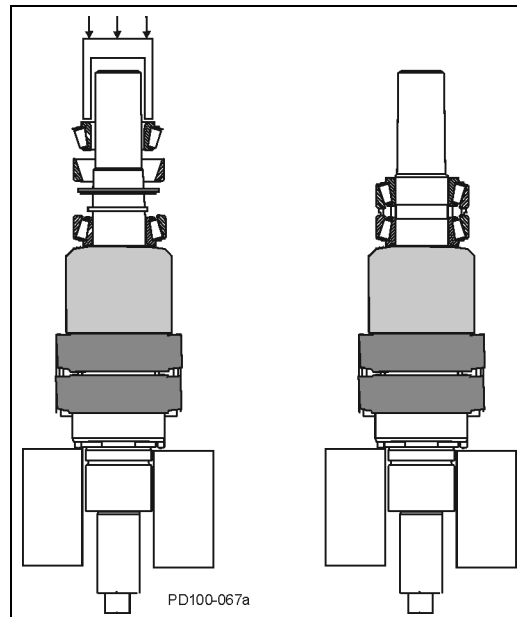
## *Rear Bearing Assembly*

Model AP015UII and AP030UII use a single self-contained ball bearing assembly for rear bearing. All other models use a tapered roller bearing assembly similar to lower front bearing.

1. Unwrap rear bearing assembly. **DO NOT** interchange parts of one bearing assembly with another. These parts are precisely matched during manufacturing and must be installed as a matched assembly.
2. **For models with ball bearing assemblies:**  
Lubricate shaft inner bearing race with oil or grease. Press bearing into place. Shielded side of bearing fits against bearing spacer. Press only on inner race.

### **For models with tapered roller bearing assemblies:**

Lubricate shaft bearing area with oil or grease. Follow “Front Bearing Assembly” procedures on page 25.



*Figure 51 - Rear Tapered Roller Bearing Assembly*

**Gear Case Assembly**

**Install Shaft**

**Shimming**

When installing shafts in gear case, shim behind front bearing to achieve proper backface clearance between back of rotors and body. **Backface clearance must be equal for both rotors to prevent rotors from hitting each other during operation.**

*NOTE: Do not install bearing retainer sealant, gears or gear locknuts until correct shimming has been verified.*

1. If shafts and/or bearings do not need to be replaced and shims are marked indicating shaft and bearing they are matched with, shim adjustment probably will not be necessary. Reuse existing tagged shims, shafts and bearings in same gear case bores.

If existing shims are lost and/or a replacement shaft is used, determine required shims from chart.

SUGGESTED SHIMS				
MODEL	STANDARD SHAFT		REPLACEMENT SHAFT	
AP015UII	0.113 in	2.87 mm	0.110 in	2.79 mm
AP030UII	0.105 in	2.67 mm	0.102 in	2.59 mm
AP045UII AP060UII	0.093 in	2.36 mm	0.088 in	2.24 mm

*NOTE: Arrange with thicker shims on outside of shim pack.*

If necessary to calculate required shims for replacement shafts, bearings or both, refer to Figure 52 and Figure 53; carry measurements and calculations to three decimal places (i.e. 0.059).

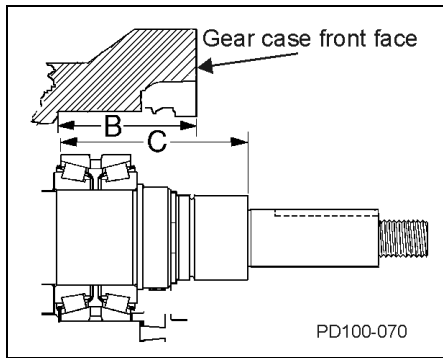


Figure 52 - Measure B and C

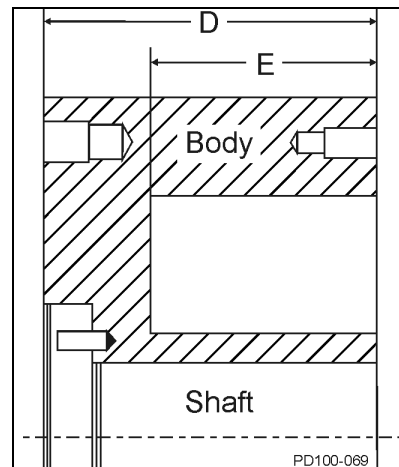


Figure 53 - Measure D and E

B. Front face of gear case to back of bearing bore.	D. Body thickness.
C. Shaft shoulder to back of bearing race.	E. Depth of rotor cavity.

Determine shim thickness required for front bearing:

- Measure “B” in gear case and “C” on shaft.
- Measure “D” and “E” on body.
- Determine proper backface clearance. Refer to “Standard Rotor Clearance” on page 30.
- Required Shims =  
Backface clearance - C + B + D - E.

2. Place shims in body resting against shoulder in front bearing bore.
3. With shims in place, install shaft assembly in front bearing bore with fluid end up. Ensure shaft is installed in its original location.

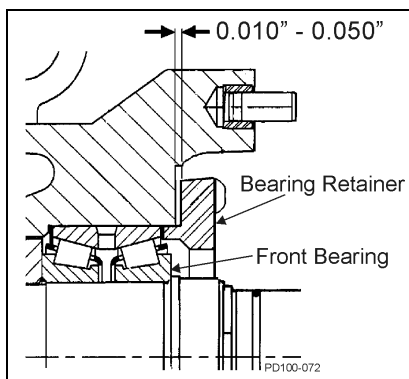
*NOTE: Shafts may need to be removed for final shim adjustment.*

4. Lubricate outside diameter of bearing.

- Use a Waukesha Cherry-Burrell Shaft Assembly Pusher to press shaft into place until seated against shim pack. **Press only against outer race of bearing.** For proper Shaft Assembly Pusher, see Parts Lists beginning on page 34.

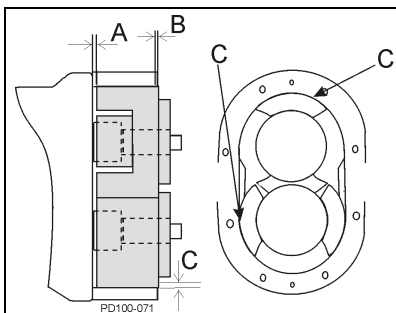
**NOTE:** A tube of the same diameter as outer race of bearing also can be used to press shaft into place.

- Temporarily secure shaft/bearing in place with bearing retainers to aid in checking clearances. **DO NOT** install Gore-Tex<sup>®</sup> sealing tape at this time.
- Bearing retainer must rest firmly against bearing. Leave a 0.010 to 0.050 in (.25 to 1.25 mm) clearance between back of bearing retainer and front of gear case (Figure 54). If this clearance is not met, place shims between bearing and retainer.



**Figure 54 - Bearing Retainer Clearance**

- Temporarily mount body on gear case.
- Secure body to gear case using body retaining screws.
- Install rotors and rotor nuts. Rotor nut o-rings, belleville washers and retainer o-rings are not required at this time.
- Measure rotor backface clearance (Figure 55, item A) through the port or from the front. Backface clearance for both rotors must be the same to prevent rotor crossover contact and must be  $\pm 0.0005$ " of value found on "Standard Rotor Clearance" on page 30.



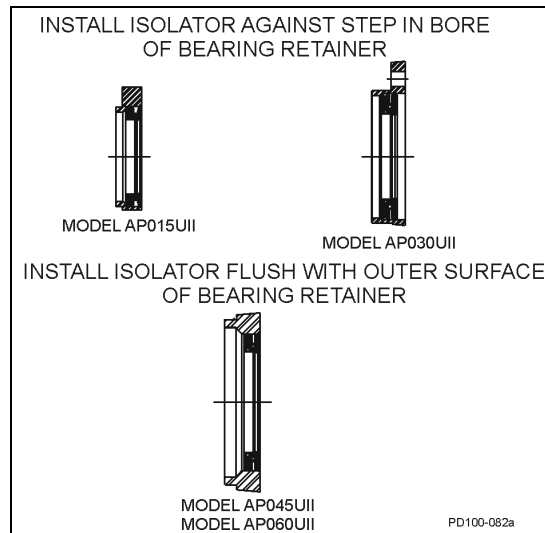
**Figure 55 - Measure Clearance**

- Check rotor front face clearance (Figure 55, item B).

- Check rotor to body clearance (Figure 55, item C).
- Check clearances against "Standard Rotor Clearance" on page 30. For non-standard rotors, check with factory.

**NOTE:** If process uses special clearance rotors, contact WCB with serial number of pump for clearance tolerance values.

- If backface clearance is not met, disassemble pump and adjust shimming to achieve correct backface clearance.
- If rotor to body clearance is not met or is uneven, contact Waukesha Cherry-Burrell technical services for proper adjustment procedures.
- After obtaining proper clearance, remove rotor nuts, rotors, body and bearing retainers.
- Grease front and rear bearing through grease fittings until grease is visible around bearing assemblies. Amount of grease required is listed in "Grease Quantity (per Bearing)" on page 18. Rotate shafts while greasing to disperse grease.
- Install bearing isolators. Bearing isolators should be against step on inside diameter of bearing retainer on models AP015UII and AP030UII. Bearing isolators should be flush with outer surface of bearing retainer on models AP045UII and AP060UII (Figure 56).



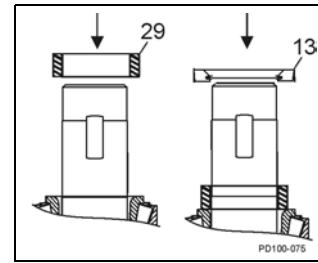
**Figure 56 - Install Bearing Isolator**

- Apply Gore-Tex<sup>®</sup> gasket material to bearing retainers.
- Slide bearing retainer/bearing isolator assembly onto lubricated shaft.
- Press the bearing retainer/bearing isolator assembly into place. Secure with bearing retainer cap screws.

## Install Rear Seal Assembly

1. Install gear spacers (Figure 57, item 29).
2. Lubricate inside and outside diameters of oil seals with oil or grease.
3. Install oil seals with spring facing out (Figure 57, item 13).

**NOTE:** Place tape or other material over shaft end to prevent cutting seal during installation.



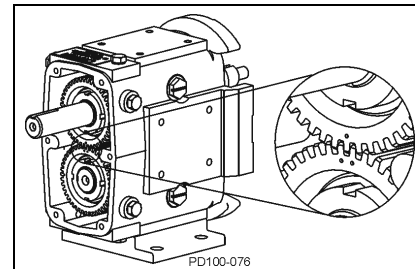
**Figure 57 - Install Rear Seal**

## Install Timing Gears

1. Place gear keys into shaft key slots. Angle keys out for easier installation of gears.

**NOTE:** To aid in timing setup, rotate rotors until they are at right angles to each other before installing gears.

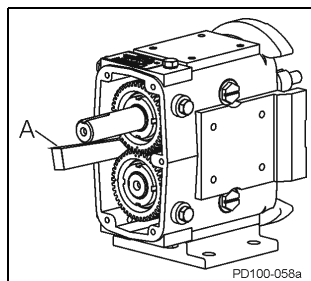
2. Slide spur gear onto drive shaft.
3. Slide spur gear onto short shaft. Straddle single punch mark of spur drive gear with two punch marks on short shaft gear (Figure 58).



**Figure 58 - Timing Gear Marks**

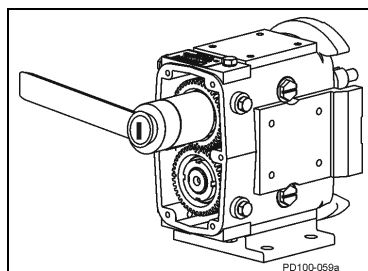
## Install Gear Case Cover

1. Use wood or nylon block (Figure 59, item A) to secure shafts from turning. If block is not available, use rags to block gears, or with one rotor on shaft, block rotor with nylon dowel.



**Figure 59 - Block Shaft Rotation**

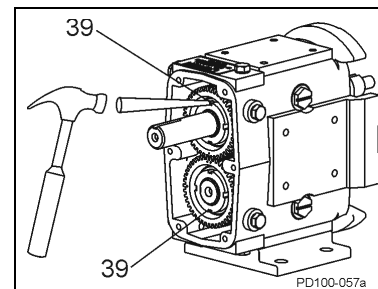
2. Slide lockwashers onto shaft. Lubricate threaded area on shafts and face of locknuts with oil or grease.
3. Using a Waukesha Cherry-Burrell Gear Locknut Tool, tighten gear locknuts. For proper Gear Locknut Tool, see Parts Lists beginning on on page 34.



**Figure 60 - Install Gear Locknuts**

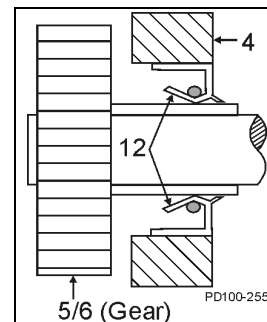
**NOTE:** Although recommended specifications cannot be assured without the use of Gear Locknut Tool, gear locknuts can be installed using spanner wrench or drift.

4. Bend locking tab on lockwashers into locking nut slots securing gear locknut into place (Figure 61).



**Figure 61 - Bend Lock Tab on Lockwashers**

5. Lubricate inside diameter of new oil seal.
6. Press new oil seal (Figure 62, item 12) into gear case cover flush with outside face, spring facing in.

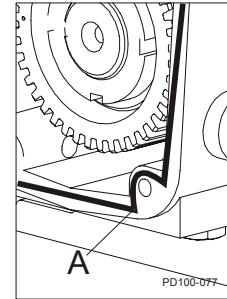


**Figure 62 - Orientation of Oil Seal**

7. Apply Gore-Tex<sup>®</sup> sealing tape to back of gear case. Place tape on inside of screw holes. (Figure 63, item A).
8. Tape shaft end to prevent cutting seal on keyway. Mount cover assembly on gear case. Secure with cap screws and washers.

**NOTE:** Ensure shaft is centered in lip seal before securing cap screws.

9. Install oil drain plug.
10. Fill gear case with gear oil to proper level. Refer to "Lubrication" on page 18.



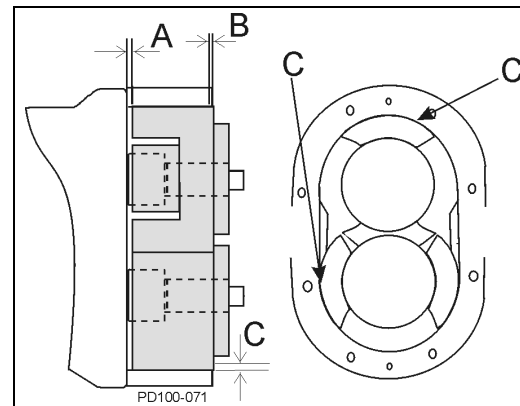
**Figure 63 - Sealant Placement**

## Checking for Proper Clearance

Waukesha Cherry-Burrell pumps are designed with close running clearances. Backface clearances are set with shims during assembly.

Shafts are positioned with shims behind front bearing and locked into gear case with bearing retainers. Rotors lock against shaft shoulder. Clearance between body backface and back of rotor wing is called backface clearance.

1. Measure rotor backface clearance (Figure 64, item A) through port or from front. **Backface clearance for both rotors must be equal to avoid crossover interference.**
2. Measure rotor front face clearance (item B).
3. Measure rotor to body clearance (item C).
4. Check measured clearances against recommended Standard Rotor Clearances chart at right.
5. If clearances are greater than values listed and desired performance is not achieved, contact Waukesha Cherry-Burrell technical services for guidance.

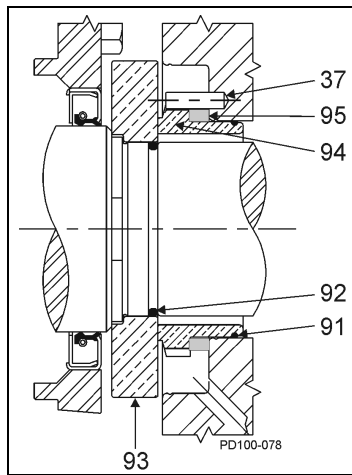


**Figure 64 - Clearance Measurements**

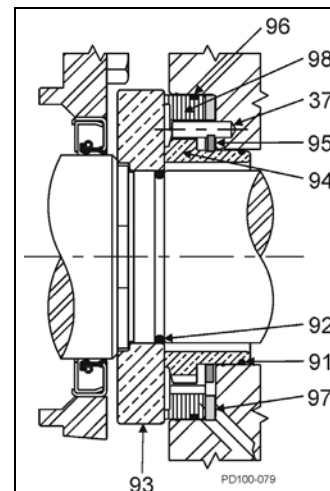
STANDARD ROTOR CLEARANCE			
MODEL	A BACK FACE	B FRONT FACE	C ROTOR TO BODY
AP015UII	0.002 in 0.05 mm	0.005 in 0.13 mm	0.002 in 0.05 mm
AP030UII	0.002 in 0.05 mm	0.005 in 0.13 mm	0.002 in 0.05 mm
AP045UII AP060UII	0.004 in 0.10 mm	0.008 in 0.20 mm	0.005 in 0.13 mm

**Fluid Head Assembly**

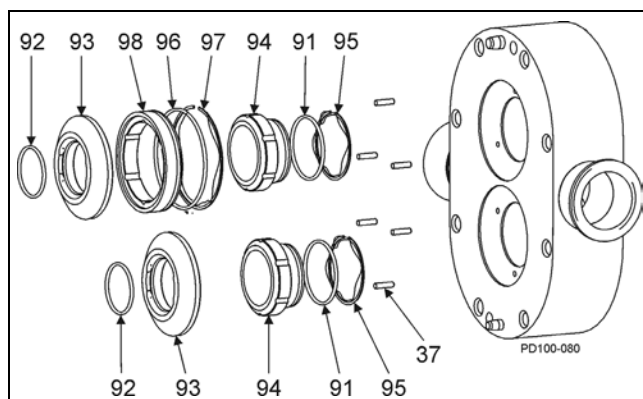
**Single Mechanical Seal Configuration**



**Figure 65 - Single Mechanical Seal Cross Section**



**Figure 66 - Double Mechanical Seal Cross Section**



**Figure 67 - Single (Bottom) and Double (Top) Mechanical Seal Exploded View**

37. Stop Pin	95. Inner Wave Spring
91. Inner Seal O-ring	96. Outer Seal O-ring
92. Shaft O-ring	97. Outer Wave Spring
93. Seal Seat	98. Outer Seal
94. Inner Seal	

**Install Mechanical Seal**

1. Lubricate shaft o-ring (Figure 67, item 92) with lubrication compound compatible with o-ring material and process fluid(s). Place o-ring on shaft.
2. Install rotating seal seat (item 93) on shaft. Align drive flats on seat with drive flats on shaft.
3. Push seat squarely against shaft shoulder.
4. Install inner wave spring (item 95) onto inner seal (item 94).
5. Lubricate inner seal o-ring (item 91) with lubrication compound compatible with o-ring material and process fluid(s). Install inner seal o-ring into groove of inner seal.
6. Place inner seal into back of pump body. Ensure notches are aligned in inner seal with stop pins in body. Press firmly and evenly into place.
7. If double mechanical seal is used, install outer wave spring in body and outer o-ring in outer seal groove. Place outer seal in pump body around inner seal, aligning notches in outer seal with stop pins in body.
8. Inspect seal faces for cleanliness. Ensure faces have no nicks or scratches. Lubricate seal faces with lubricant compatible with process fluid(s).
9. Perform steps 1 through 5 on both shafts.

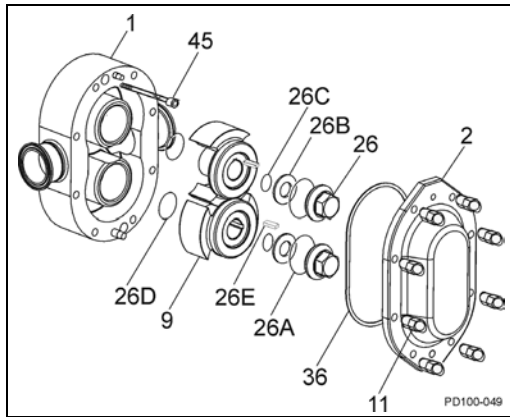


Figure 68 - Exploded View of Fluid Head

1. Body	26B. Belleville Washer
2. Cover	26C. Retainer O-ring
9. Rotor	26D. Rotor Hub O-ring*
11. Cover Nut	26E. Rotor Key
26. Rotor Nut	36. Cover O-ring
26A. Rotor Nut O-ring*	45. Body Retaining Cap Screw

\*Discard rotor hub and rotor nut o-rings; one-time use only.

**Install Pump Body**

1. Match large and small dowel pin sizes on gear case with dowel pin holes in pump body.
2. Install body (Figure 68, item 1) to gear case assembly aligning body with body studs. Avoid damaging seals as body is drawn over shafts.
3. Secure body to gear case using two cap screws (Figure 68, item 45).

**Install Rotors**

1. Lubricate o-rings (Figure 68, item 26A and 26D) with lubrication compound compatible with o-ring material and process fluid(s).
2. Install new rotor hub o-rings (item 26D) into groove on rotors hubs.
3. Install rotors (item 9) onto shafts.
4. Align keyways in rotors with keyways on shafts and install keys (item 26E).

**Install Rotor Nut Assemblies**

1. Install belleville washer (Figure 68, item 26B) into rotor nut with outer raised side of washer toward rotor nut.
2. Place retainer o-ring (item 26C) into rotor nut to retain belleville washer. Washer should not be tight against o-ring.

3. Lubricate new rotor nut o-ring (item 26A) with lubrication compound compatible with o-ring material and process fluid(s). If o-ring is not lubricated it will pucker when tightening rotor nut.
4. Install rotor nut o-ring onto rotor nut.
5. Prior to assembly of rotor nuts, apply anti-seize compound compatible with product to shaft threads.
6. Use blocking dowel (Figure 69) to prevent rotors from turning during installation. See “Blocking Dowels” on page 22 for rotor blocking dowel size. Always use dowel to block rotor against body, not against other rotor. See Figure 70 and Figure 71.



Figure 69 - Blocking Dowel

7. Screw rotor nuts (Figure 68, item 26) onto shafts (clockwise) and tighten to required torque.



**CAUTION:** Use torque wrench to tighten rotor nuts to proper torque. Failure to tighten nuts properly could result in nuts loosening during operation, causing damage to pump.



Figure 70 - Tightening Bottom Rotor

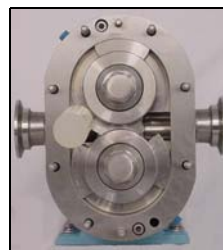


Figure 71 - Tightening Top Rotor



## Install Cover

1. Clean cover o-ring (Figure 68, item 36) and install in groove in cover.
2. Match large and small dowel pin sizes on pump body with dowel pin holes in cover.
3. Install cover (Figure 68, item 2) on pump body.
4. Prior to assembly of cover nuts, apply anti-seize compound compatible with product to threads of body studs.
5. Tighten cover securely using cover nuts (Figure 68, item 11).



**CAUTION:** Failure to tighten cover nuts to proper torque could cause body studs to fail prematurely under high pressure.

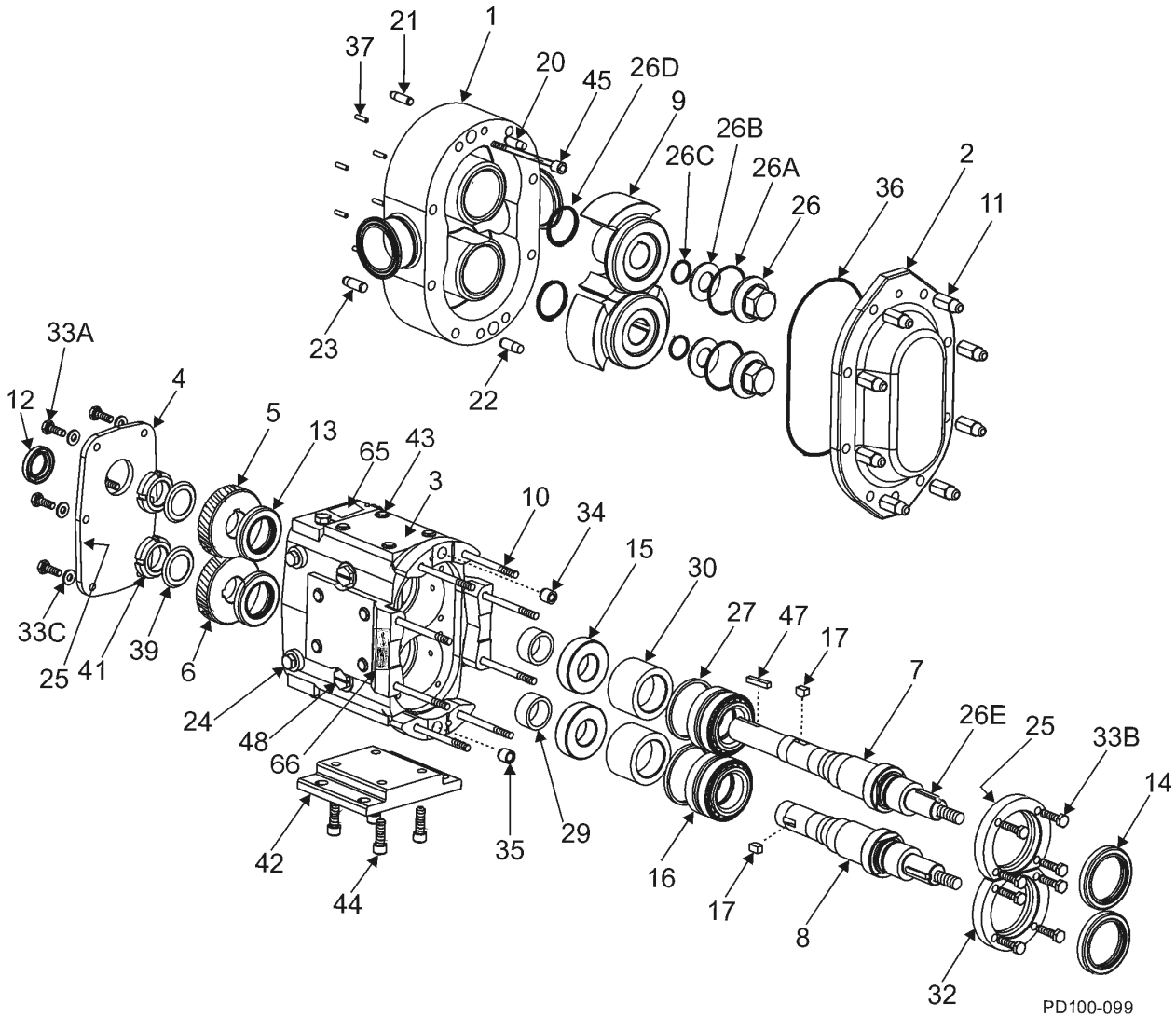
UNIVERSAL II WRENCH SIZE			
MODEL	ROTOR NUT	BODY RETAINING CAP SCREW	COVER NUT
AP015UII	15/16"	3/16"	5/8"
AP030UII	1-1/4"	3/16"	5/8"
AP045UII AP060UII	1-5/8"	1/4"	7/8"

TORQUE VALUES				
MODEL	LOCKNUTS			LOCKNUT TOOL
	GEAR	ROTOR	COVER	
AP015UII	75 ft lbs 1035 kg cm	50 ft lbs 690 kg cm	5.8 ft lbs 80 kg cm	109281
AP030UII	100 ft lbs 1380 kg cm	120 ft lbs 1656 kg cm	10.8 in lbs 149 kg cm	109282
AP045UII	140 ft lbs 1932 kg cm	250 ft lbs 3450 kg cm	56 ft lbs 772.8 kg cm	109283
AP060UII	140 ft lbs 1932 kg cm	250 ft lbs 3450 kg cm	38 ft lbs 524.4 kg cm	109283

ARBOR OR HYDRAULIC PRESS TONNAGE						
MODEL	SHAFT		FRONT BEARING		REAR BEARING	
	IN	OUT	ON	OFF	ON	OFF
AP015UII	0.25	0.50	0.50	1.00	0.50	1.00
AP030UII	0.25	1.00	0.50	1.00	0.50	1.00
AP045UII AP060UII	0.50	1.00	2.00	5.00	3.00	5.00

**Parts Lists**

**AP015UII Pump**



PD100-099

ITEM #	DESCRIPTION	QTY PER PUMP	PART #
1	Pump Body	1	(Serial # Req'd)
2	Pump Cover	1	101842
3	Gear Case, Painted Cast Iron	1	102276
4	Gear Case Cover, Steel	1	020 006 000
5	Gear, Drive Shaft, Spur	1	107997
6	Gear, Short Shaft, Spur	1	107997
7	Drive Shaft	1	108405
8	Short Shaft	1	108406
9	Rotor, Twin Wing, Alloy 88	2	101882
10	Stud	8	AD0 011 000
11	Hex Nut	8	108369
12	Oil Seals, Gear Case Cover	1	000 030 016
13	Oil Seals, Gear Case Rear	2	000 030 017

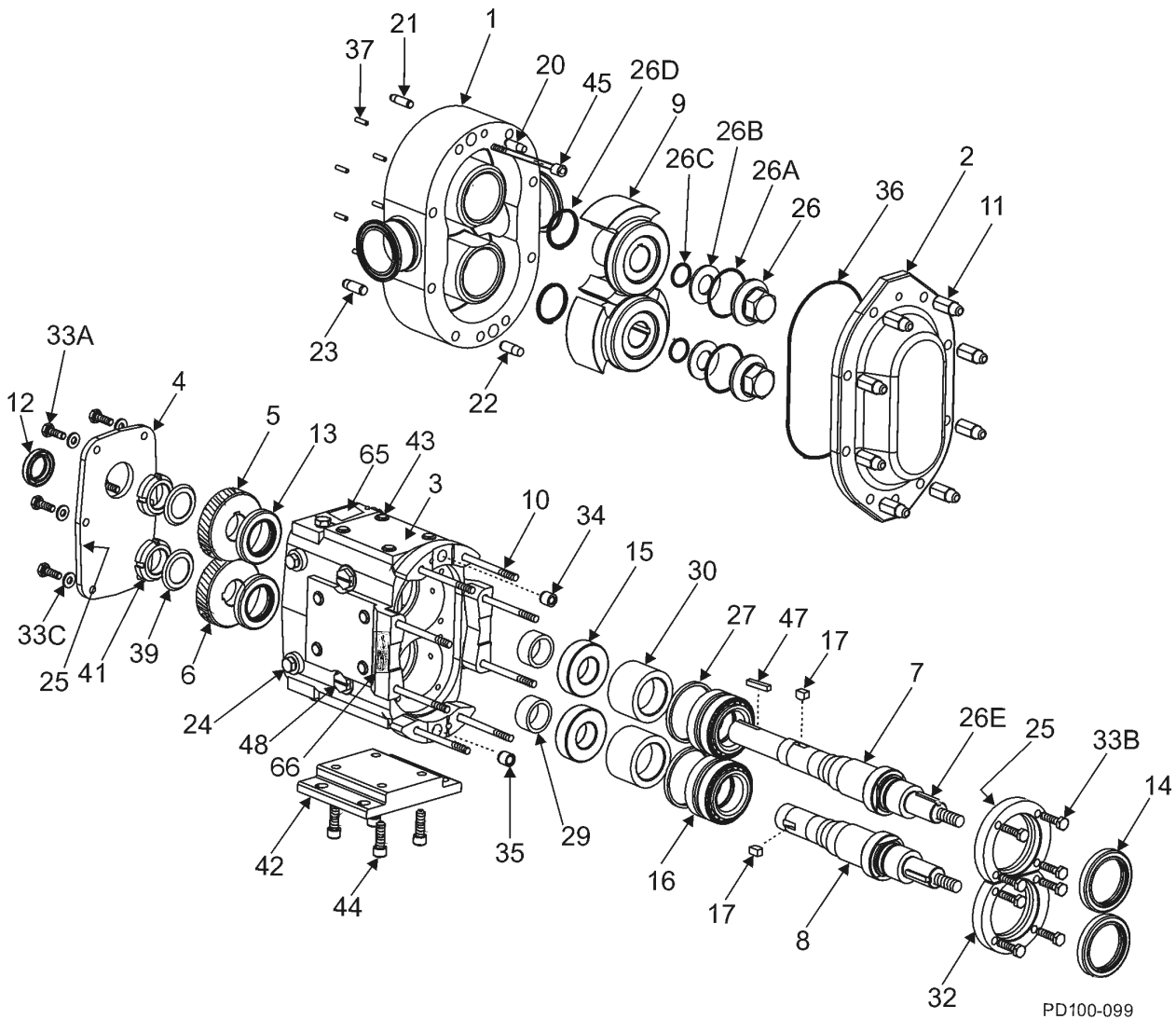
PD100-396a.1

**AP015UII Pump**

ITEM #	DESCRIPTION	QTY PER PUMP	PART #
14	Bearing Isolator Kit (includes SS Bearing Retainer)	2	X06639-1
15	Bearings, Rear	2	030 035 000
16	Bearings, Front	2	101715
17	Key, Gear	2	BD0 037 000
20	Dowel Pins, Upper Cover Side	1	BD0 040 000
21	Dowel Pins, Upper Gear Case Side	1	BD0 040 200
22	Dowel Pins, Lower Cover Side	1	BD0 040 100
23	Dowel Pins, Lower Gear Case Side	1	BD0 040 300
24	Plug; Fill, Drain, Level	6	000 046 003
25	Gore-Tex® Tape Sealant - 48"	1	35850
26	Nut, Rotor	2	101805
26A	O-ring, Rotor Nut, PTFE Encapsulated	2	T80130
26B	Washer, Belleville	2	101692
26C	O-ring, Retainer, PTFE Encapsulated	2	T80115
26D	O-ring, Rotor Hub, PTFE Encapsulated	2	T80127
26E	Key, Rotor	2	101821
27	Shim Kit, Front Bearing	2	117890
29	Spacer, Gear to Rear Bearing	2	030 055 000
30	Bearing Spacer	2	101815
32	Bearing Retainer, Front	2	101811
33A	5/16-18 x 3/4" HHCS, STD	6	30-283
33B	5/16-18 x 3/4" BSHCS, STD	8	30-296
33C	5/16 Flat Washer	6	43-194
34	Dowel Bushings, Upper	1	BD0 116 000
35	Dowel Bushings, Lower	1	BD0 116 100
36	O-ring, Pump Cover, Kalrez®	1	K75259
37	Stop Pin, Seal	6	101719
39	Lockwasher, Gear	2	CD0 036 W00
41	Locknut, Gear	2	CD0 036 N00
42	Gear Case Shim, CI	1	040 110 000
43	Plastic Cap Plug, 3/8"	8	000 121 002
44	3/8-16 x 1" SHCS, STD	4	30-344
45	Body Retaining Screw, 1/4-20 x 2"	2	30-211
47	Key, Coupling - 1/4" x 1/4" x 1-3/4"	1	000 037 002
48	Cleanout Plug	2	41013
61	Name Plate (not shown)	1	001 061 015
62	#2 x 1/8" RHDS (not shown)	4	30-355
65	Caution Plate	2	33-62
66	Warning Label	2	33-63
67	Grease Fitting, 1/8" (not shown)	4	BD0 092 000
68	Plastic Cap, Grease Fitting (not shown)	4	BD0 093 000
	Silicone-Free Label	1	33-35
	Gear Locknut Tool	1	109282
	Shaft Assembly Pusher	1	109351

PD 100-3966.2

**AP030UII Pump**



PD100-099

ITEM #	DESCRIPTION	QTY PER PUMP	PART #
1	Pump Body	1	(Serial # Req'd)
2	Pump Cover	1	101845
3	Gear Case, Painted Cast Iron	1	102277
4	Gear Case Cover, Steel	1	040 106 000
5	Gear, Drive Shaft, Spur	1	107999
6	Gear, Short Shaft, Spur	1	107999
7	Drive Shaft	1	108409
8	Short Shaft	1	108410
9	Rotor, Twin Wing, Alloy 88	2	102151
10	Stud	8	108842
11	Hex Nut	8	108370
12	Oil Seals, Gear Case Cover	1	000 030 013
13	Oil Seals, Gear Case Rear	2	000 030 014

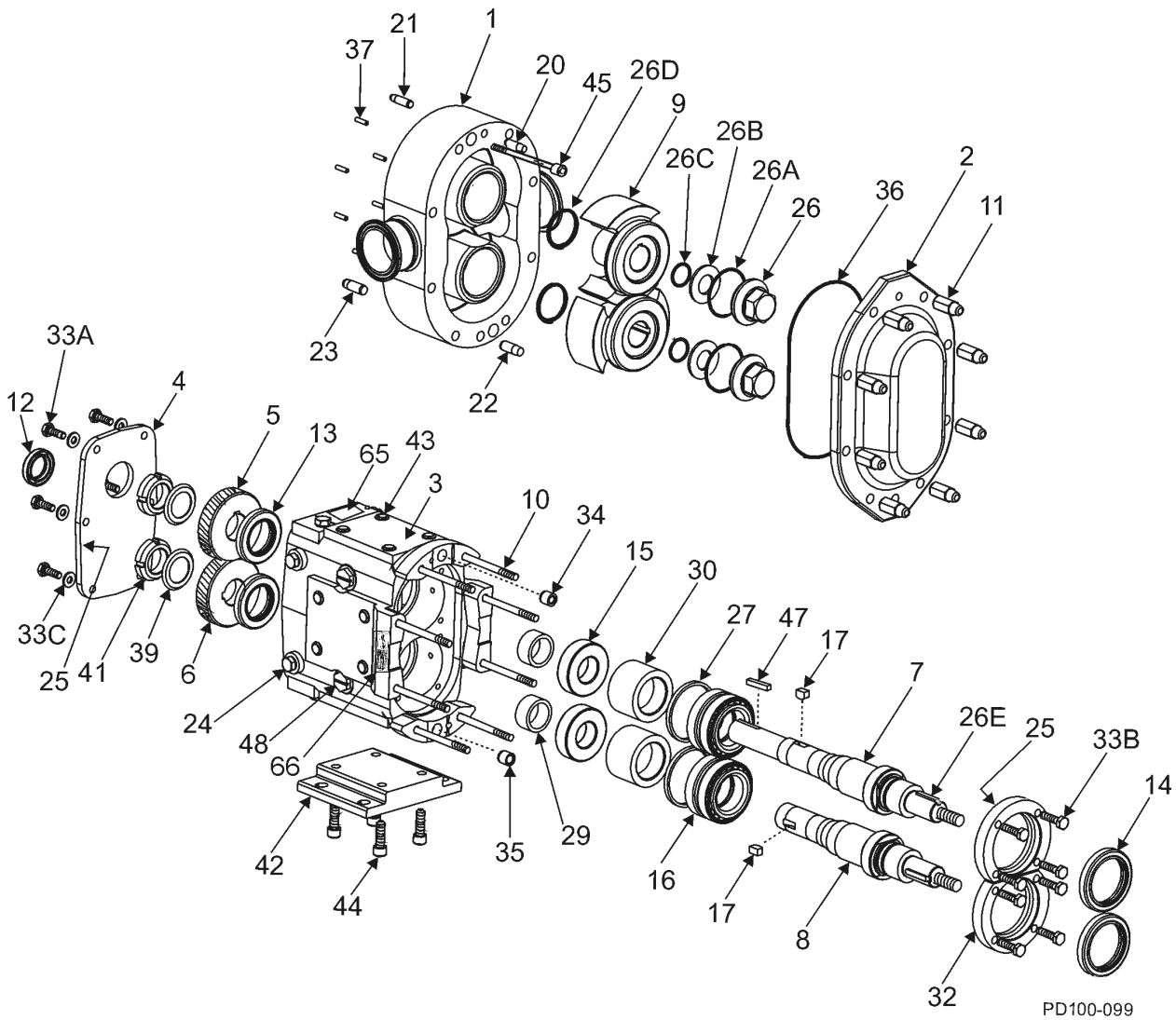
PD 100-396b.1

**AP030UII Pump**

ITEM #	DESCRIPTION	QTY PER PUMP	PART #
14	Bearing Isolator Kit (includes SS Bearing Retainer)	2	X06639-1
15	Bearings, Rear	2	030 035 000
16	Bearings, Front	2	101715
17	Key, Gear	2	BD0 037 000
20	Dowel Pins, Upper Cover Side	1	BD0 040 000
21	Dowel Pins, Upper Gear Case Side	1	BD0 040 200
22	Dowel Pins, Lower Cover Side	1	BD0 040 100
23	Dowel Pins, Lower Gear Case Side	1	BD0 040 300
24	Plug; Fill, Drain, Level	6	000 046 003
25	Gore-Tex <sup>®</sup> Tape Sealant - 48"	1	35850
26	Nut, Rotor	2	101805
26A	O-ring, Rotor Nut, PTFE Encapsulated	2	T80130
26B	Washer, Belleville	2	101692
26C	O-ring, Retainer, PTFE Encapsulated	2	T80115
26D	O-ring, Rotor Hub, PTFE Encapsulated	2	T80127
26E	Key, Rotor	2	101821
27	Shim Kit, Front Bearing	2	117890
29	Spacer, Gear to Rear Bearing	2	030 055 000
30	Bearing Spacer	2	101815
32	Bearing Retainer, Front	2	101811
33A	5/16-18 x 3/4" HHCS, STD	6	30-283
33B	5/16-18 x 3/4" BSHCS, STD	8	30-296
33C	5/16 Flat Washer	6	43-194
34	Dowel Bushings, Upper	1	BD0 116 000
35	Dowel Bushings, Lower	1	BD0 116 100
36	O-ring, Pump Cover, Kalrez <sup>®</sup>	1	K75259
37	Stop Pin, Seal	6	101719
39	Lockwasher, Gear	2	CD0 036 W00
41	Locknut, Gear	2	CD0 036 N00
42	Gear Case Shim, CI	1	040 110 000
43	Plastic Cap Plug, 3/8"	8	000 121 002
44	3/8-16 x 1" SHCS, STD	4	30-344
45	Body Retaining Screw, 1/4-20 x 2"	2	30-211
47	Key, Coupling - 1/4" x 1/4" x 1-3/4"	1	000 037 002
48	Cleanout Plug	2	41013
61	Name Plate (not shown)	1	001 061 015
62	#2 x 1/8" RHDS (not shown)	4	30-355
65	Caution Plate	2	33-62
66	Warning Label	2	33-63
67	Grease Fitting, 1/8" (not shown)	4	BD0 092 000
68	Plastic Cap, Grease Fitting (not shown)	4	BD0 093 000
	Silicone-Free Label	1	33-35
	Gear Locknut Tool	1	109282
	Shaft Assembly Pusher	1	109351

PD100-396b.2

**AP045UII Pump**



ITEM #	DESCRIPTION	QTY PER PUMP	PART #
1	Pump Body	1	(Serial # Req'd)
2	Pump Cover	1	101848
3	Gear Case, Painted Cast Iron	1	070 005 000
4	Gear Case Cover, Steel	1	070 006 000
5	Gear, Drive Shaft, Spur	1	107404
6	Gear, Short Shaft, Spur	1	107404
7	Drive Shaft	1	110021
8	Short Shaft	1	110022
9	Rotor, Twin Wing, Alloy 88	2	107252
10	Stud	8	107242
11	Hex Nut	8	108371
12	Oil Seals, Gear Case Cover	1	000 030 012
13	Oil Seals, Gear Case Rear	2	000 030 011

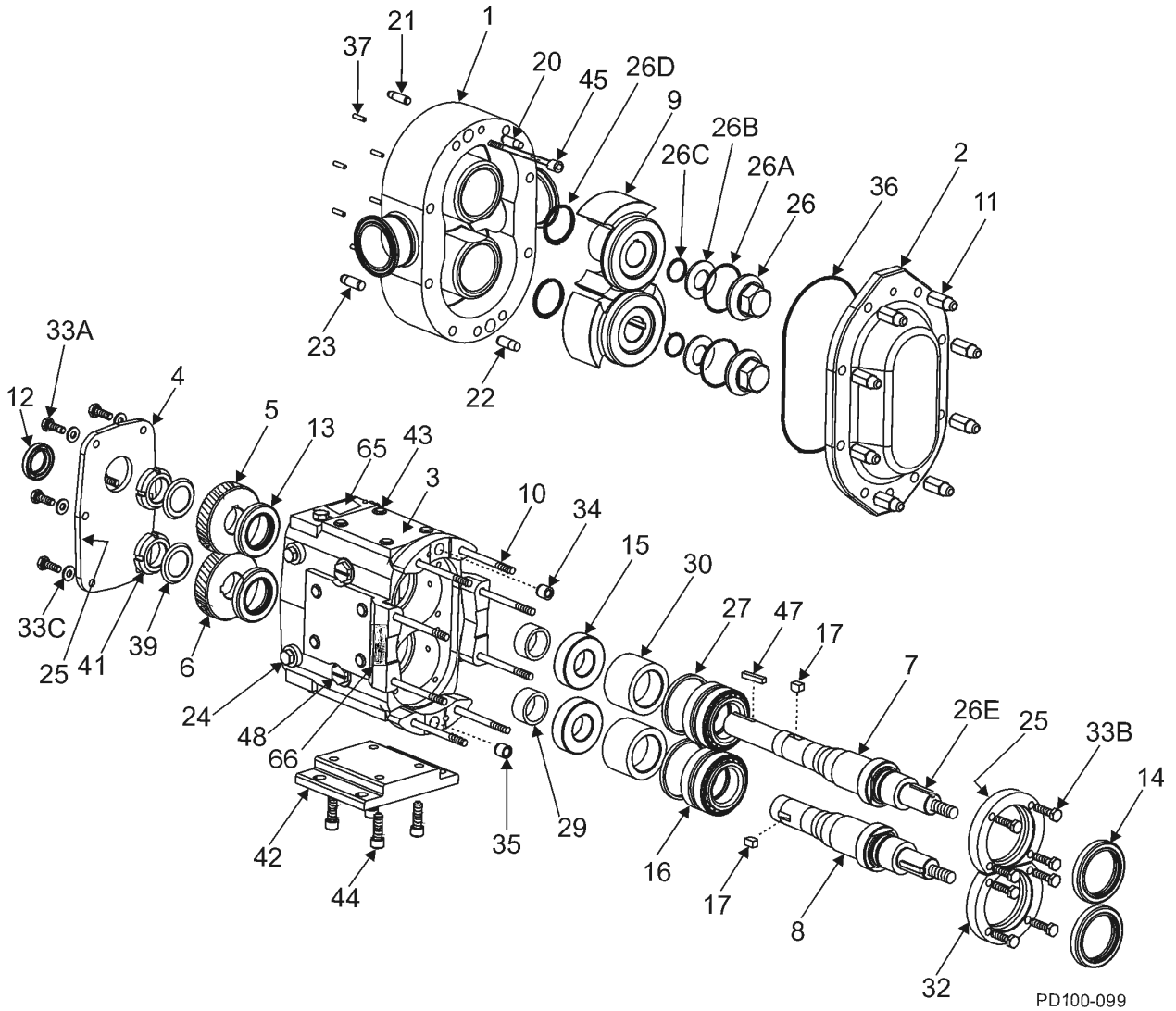
PD100-396c.1

**AP045UII Pump**

ITEM #	DESCRIPTION	QTY PER PUMP	PART #
14	Bearing Isolator Kit (includes SS Bearing Retainer)	2	X06614-2
15	Bearings, Rear	2	107186
16	Bearings, Front	2	060 036 000
17	Key, Gear	2	060 037 000
20	Dow el Pins, Upper Cover Side	1	CD0 040 000
21	Dow el Pins, Upper Gear Case Side	1	CD0 040 R00
22	Dow el Pins, Low er Cover Side	1	CD0 040 100
23	Dow el Pins, Low er Gear Case Side	1	CD0 040 R10
24A	Oil Plug, M20 x 1.5"	5	115798
24B	Oil Level Indicator, M20 x 1.5"	1	115799
25	Gore-Tex® Tape Sealant - 60"	1	35850
26	Nut, Rotor	2	101806
26A	O-ring, Rotor Nut, PTFE Encapsulated	2	T80227
26B	Washer, Belleville	2	101693
26C	O-ring, Retainer, PTFE Encapsulated	2	T80119
26D	O-ring, Rotor Hub, PTFE Encapsulated	2	T80224
26E	Key, Rotor	2	110926
27	Shim Kit, Front Bearing	2	117891
29	Spacer, Gear to Rear Bearing	2	107187
30	Bearing Spacer	2	060 055 003
31	Grease Retainer (not show n)	2	STD 091 002
32	Bearing Retainer, Front	2	060 080 000
33A	3/8-16 x 3/4" HHCS, STD	6	30-314
33B	3/8-16 x 1-1/4" HHCS, STD	8	30-351
33C	3/8 Flat Washer	6	43-189
34	Dow el Bushings, Upper	1	CD0 116 000
35	Dow el Bushings, Low er	1	CD0 116 100
36	O-ring, Pump Cover, PTFE Encapsulated	1	T80373
37	Stop Pin, Seal	6	101720
39	Lockw asher, Gear	2	STD 136 009
41	Locknut, Gear	2	STD 236 009
42	Gear Case Shim, Cl	1	070 110 000
43	Plastic Cap Plug, 1/2"	6	000 121 001
44	1/2-13 x 1-1/4" SHCS, STD	4	30-275
45	Body Retaining Screw , 5/16-18 x 2-1/2"	2	30-615
46	Eye Bolt, 1/2-13 x 3/4" (not show n)	2	30-360
47	Key, Coupling - 3/8" x 3/8" x 1-5/8"	1	000 037 003
48	Cleanout Plug	2	41013
61	Name Plate (not show n)	1	001 061 015
62	#2 x 1/8" RHDS (not show n)	4	30-355
65	Caution Plate	2	33-62
66	Warning Label	2	33-60
67	Grease Fitting, 1/8" (not show n)	4	BD0 092 000
68	Plastic Cap, Grease Fitting (not show n)	4	BD0 093 000
	Silicone-Free Label	1	33-35
	Gear Locknut Tool	1	109283
	Shaft Assembly Pusher	1	109352

PD100-396c.2

**AP060UII Pump**



PD100-099

ITEM #	DESCRIPTION	QTY PER PUMP	PART #
1	Pump Body	1	(Serial # Req'd)
2	Pump Cover	1	101848
3	Gear Case, Painted Cast Iron	1	070 005 000
4	Gear Case Cover, Steel	1	070 006 000
5	Gear, Drive Shaft, Spur	1	107404
6	Gear, Short Shaft, Spur	1	107404
7	Drive Shaft	1	108411
8	Short Shaft	1	108412
9	Rotor, Twin Wing, Alloy 88	2	102163
10	Stud	8	108843
11	Hex Nut	8	108371
12	Oil Seals, Gear Case Cover	1	000 030 012
13	Oil Seals, Gear Case Rear	2	000 030 011

PD100-396d.1

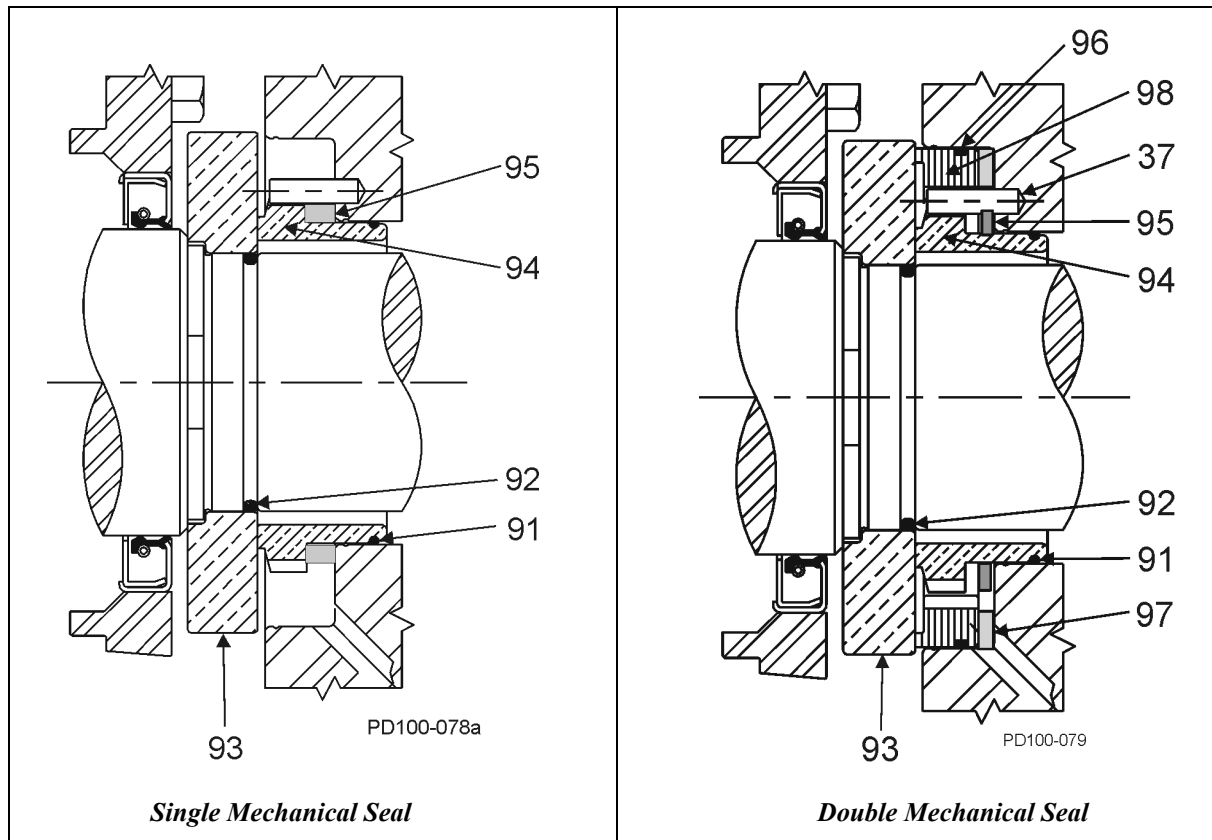


**AP060UII Pump**

ITEM #	DESCRIPTION	QTY PER PUMP	PART #
14	Bearing Isolator Kit (includes SS Bearing Retainer)	2	X06614-2
15	Bearings, Rear	2	107186
16	Bearings, Front	2	060 036 000
17	Key, Gear	2	060 037 000
20	Dowel Pins, Upper Cover Side	1	CD0 040 000
21	Dowel Pins, Upper Gear Case Side	1	CD0 040 R00
22	Dowel Pins, Lower Cover Side	1	CD0 040 100
23	Dowel Pins, Lower Gear Case Side	1	CD0 040 R10
24A	Oil Plug, M20 x 1.5"	5	115798
24B	Oil Level Indicator, M20 x 1.5"	1	115799
25	Gore-Tex® Tape Sealant - 60"	1	35850
26	Nut, Rotor	2	101806
26A	O-ring, Rotor Nut, PTFE Encapsulated	2	T80227
26B	Washer, Belleville	2	101693
26C	O-ring, Retainer, PTFE Encapsulated	2	T80119
26D	O-ring, Rotor Hub, PTFE Encapsulated	2	T80224
26E	Key, Rotor	2	101823
27	Shim Kit, Front Bearing	2	117891
29	Spacer, Gear to Rear Bearing	2	107187
30	Bearing Spacer	2	060 055 003
31	Grease Retainer (not shown)	2	STD 091 002
32	Bearing Retainer, Front	2	060 080 000
33A	3/8-16 x 3/4" HHCS, STD	6	30-314
33B	3/8-16 x 1-1/4" HHCS STD	8	30-351
33C	3/8 Flat Washer	6	43-189
34	Dowel Bushings, Upper	1	CD0 116 000
35	Dowel Bushings, Lower	1	CD0 116 100
36	O-ring, Pump Cover, PTFE Encapsulated	1	T80373
37	Stop Pin, Seal	6	101720
39	Lockwasher, Gear	2	STD 136 009
41	Locknut, Gear	2	STD 236 009
42	Gear Case Shim, CI	1	070 110 000
43	Plastic Cap Plug, 1/2"	6	000 121 001
44	1/2-13 x 1-1/4" SHCS, STD	4	30-275
45	Body Retaining Screw, 5/16-18 x 3"	2	30-319
46	Eye Bolt, 1/2-13 x 3/4" (not shown)	2	30-360
47	Key, Coupling - 3/8" x 3/8" x 1-5/8"	1	000 037 003
48	Cleanout Plug	2	41013
61	Name Plate (not shown)	1	001 061 015
62	#2 x 1/8" RHDS (not shown)	4	30-355
65	Caution Plate	2	33-62
66	Warning Label	2	33-60
67	Grease Fitting, 1/8" (not shown)	4	BD0 092 000
68	Plastic Cap, Grease Fitting (not shown)	4	BD0 093 000
	Silicone-Free Label	1	33-35
	Gear Locknut Tool	1	109283
	Shaft Assembly Pusher	1	109352

PD100-396d.2

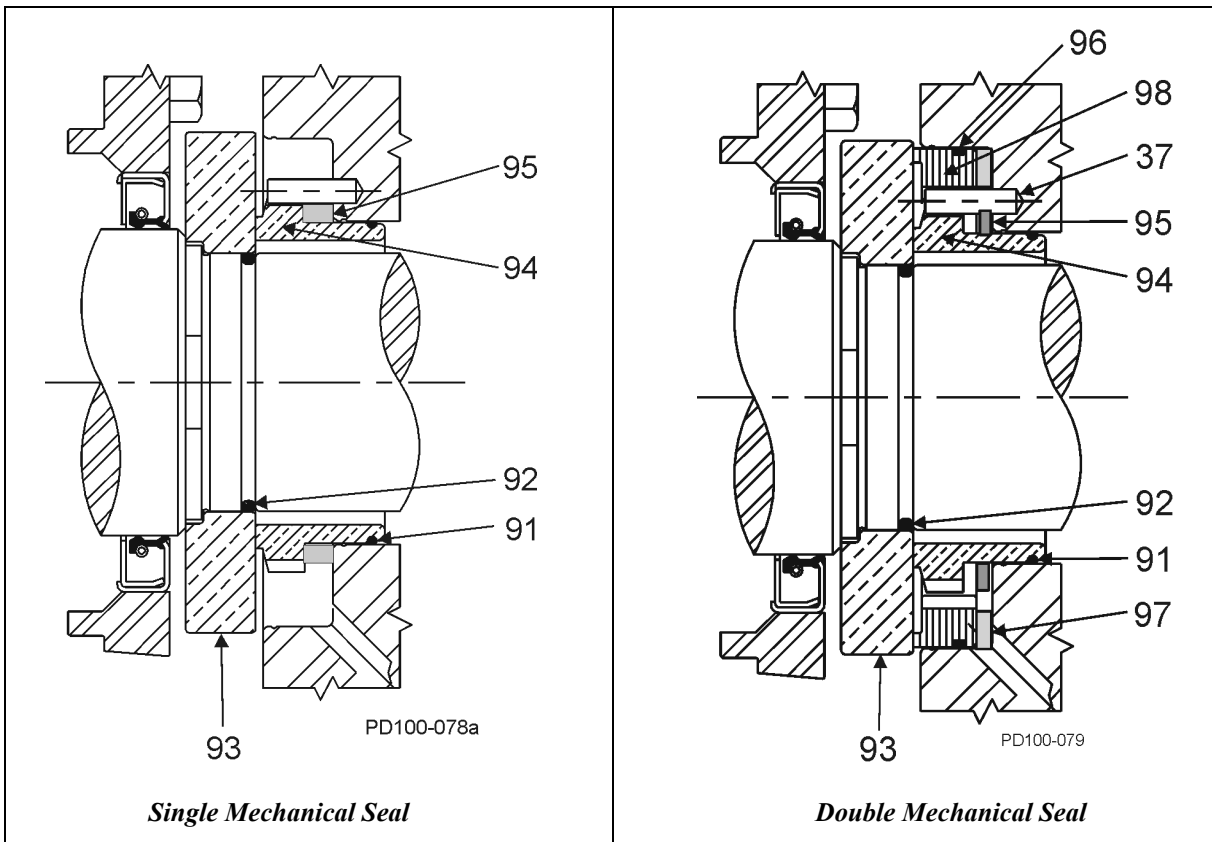
**AP015UII Pump Seal**



ITEM #	DESCRIPTION	QTY PER PUMP	PART #
91	O-ring, Inner Seal, Kalrez®	2	K75028
92	O-ring, Shaft, Kalrez®	2	K75024
93	Seal Seat, Ceramic	2	101667
94	Inner Seal, Ceramic	2	101652
95	Wave Spring, Inner Seal	2	101683
96	O-ring, Outer Seal, Kalrez®	2	K75035
97	Wave Spring, Outer Seal	2	101684
98	Outer Seal, Carbon	2	101679

PD100-397a

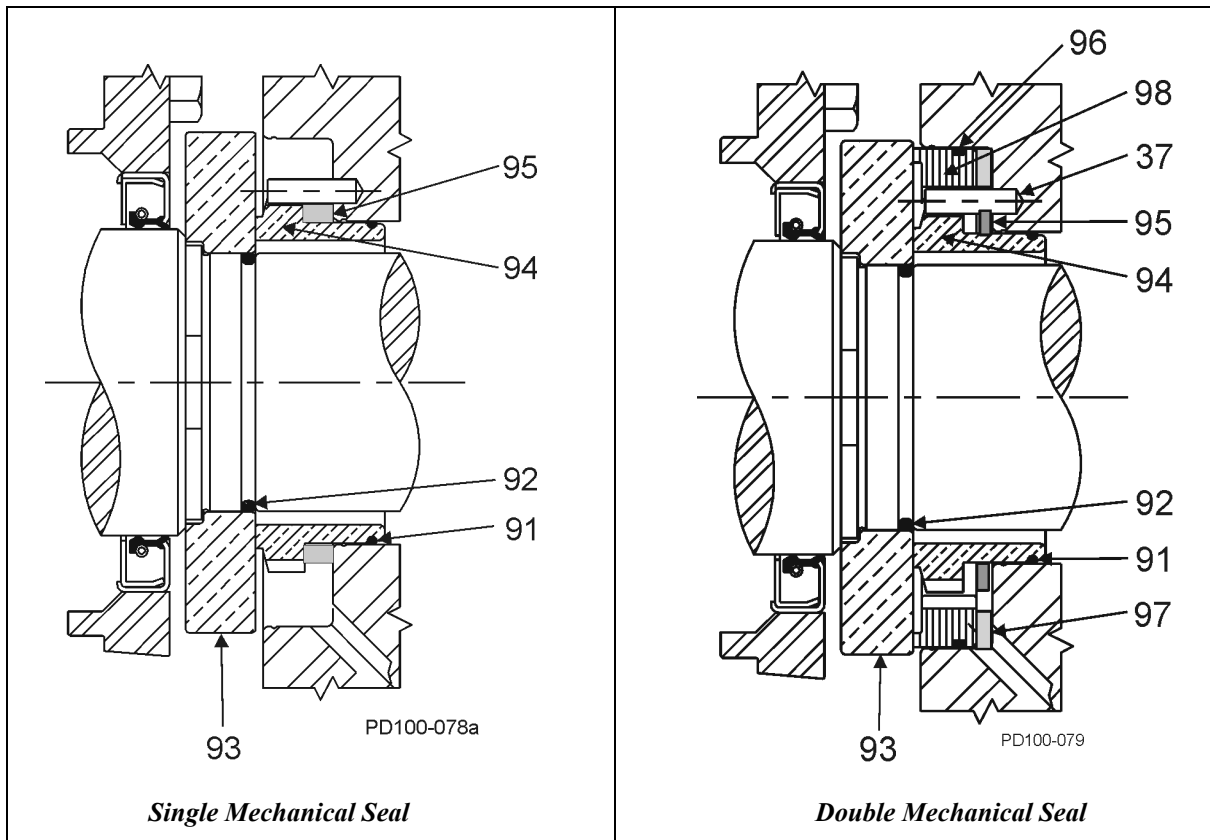
**AP030UII Pump Seal**



ITEM #	DESCRIPTION	QTY PER PUMP	PART #
91	O-ring, Inner Seal, Kalrez®	2	K75031
92	O-ring, Shaft, Kalrez®	2	K75029
93	Seal Seat, Ceramic	2	101670
94	Inner Seal, Ceramic	2	101656
95	Wave Spring	2	101685
96	O-ring, Outer Seal, Kalrez®	2	K75041
97	Wave Spring, Outer Seal	2	101686
98	Outer Seal, Carbon	2	101680

PD100-397b

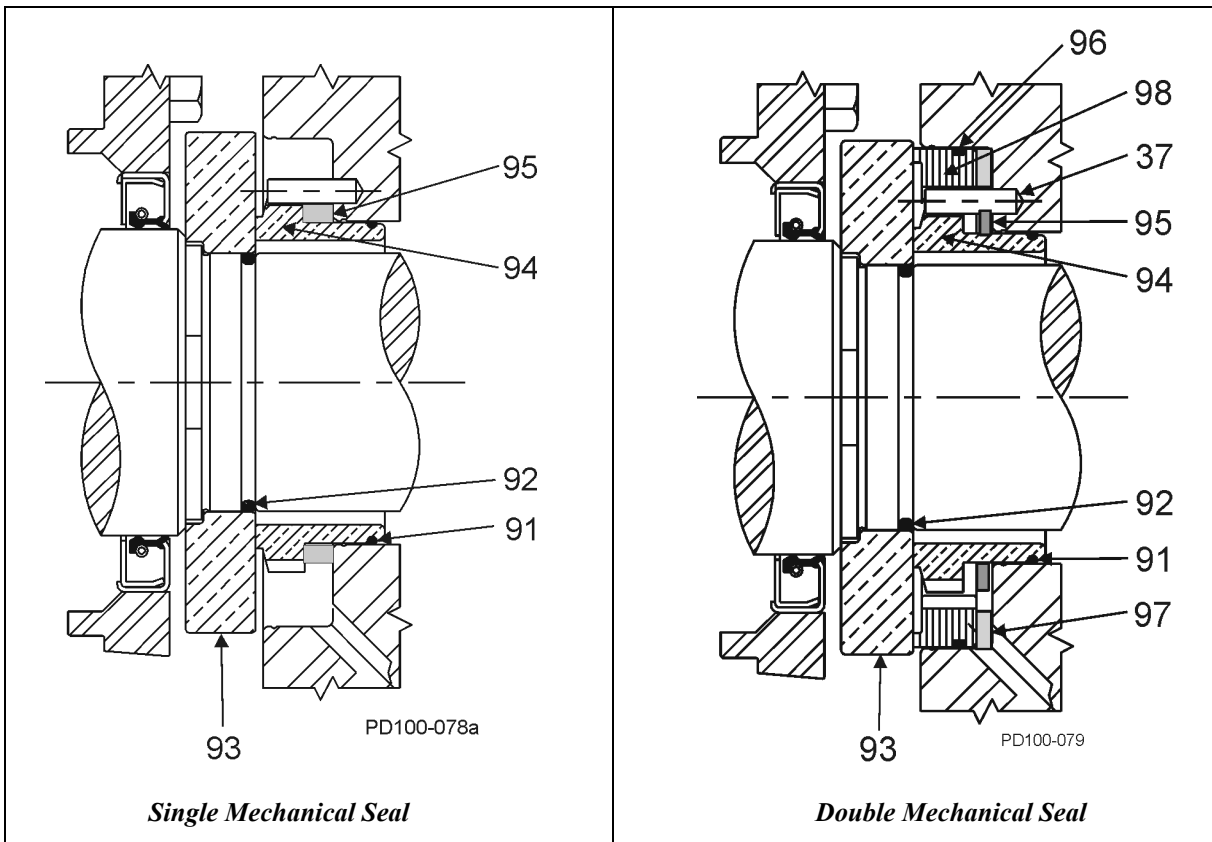
**AP045UII Pump Seal**



ITEM #	DESCRIPTION	QTY PER PUMP	PART #
91	O-ring, Inner Seal, Kalrez®	2	K75035
92	O-ring, Shaft, Kalrez®	2	K75133
93	Seal Seat, Ceramic	2	101673
94	Inner Seal, Ceramic	2	101660
95	Wave Spring	2	101687
96	O-ring, Outer Seal, Kalrez®	2	K75043
97	Wave Spring, Outer Seal	2	101688
98	Outer Seal, Carbon	2	101681

PD100-397c

**AP060UII Pump Seal**



ITEM #	DESCRIPTION	QTY PER PUMP	PART #
91	O-ring, Inner Seal, Kalrez®	2	K75035
92	O-ring, Shaft, Kalrez®	2	K75133
93	Seal Seat, Ceramic	2	101673
94	Inner Seal, Ceramic	2	101660
95	Wave Spring	2	101687
96	O-ring, Outer Seal, Kalrez®	2	K75043
97	Wave Spring, Outer Seal	2	101688
98	Outer Seal, Carbon	2	101681

PD100-397c

**Troubleshooting**

<b>PROBLEM</b>	<b>POSSIBLE CAUSE</b>	<b>POSSIBLE SOLUTIONS</b>
<b>No flow, pump rotors not turning</b>	Drive motor not running.	Check resets, fuses, circuit breakers.
	Keys sheared or missing.	Replace keys.
	Drive belts, power transmission components slipping or broken.	Inspect; replace or adjust parts as necessary.
	Pump shaft, keys, or gears sheared.	Inspect; replace parts as necessary.
<b>No flow, pump rotors turning</b>	Rotors turn in wrong direction.	Check motor hookup to reverse motor rotation.
	Relief valve not properly adjusted, or held open by foreign material.	Adjust or clear valve.
<b>No flow, pump not priming</b>	Valve closed in inlet line.	Open valve.
	Inlet line clogged or restricted.	Clear line, clean filters, etc.
	Air leaks due to bad gaskets or pipe connections.	Replace gaskets; check lines for leakage (can be done by air, by pressure or by filling with liquid and pressurizing with air).
	Pump speed too slow.	Increase pump speed.
	Liquid drains or siphons from system during off periods.	Use foot valve or check valves. Filling inlet lines with material before startup may solve startup priming problems due to no material in system.
	“Air” lock caused by fluids which “gas off”, or vaporize, or allow gas to come out of solution during off periods.	Install and use a manual or automatic air bleed from pump or lines near pump.
	Extra clearance rotors, worn pump.	Increase pump speed, use foot valve to improve priming.
	NIPA (Net Inlet Pressure Available) too low.	Check NIPA and NIPR (Net Inlet Pressure Required). Change inlet system as needed.
<b>Insufficient flow</b>	On “Vacuum” inlet system: On initial start-up, atmospheric “blow back” prevents pump from developing enough differential pressure to start flow.	Install check valve in discharge line.
	Speed too low to obtain desired flow.	Check flow-speed curve (available from WCB customer service) and adjust as necessary.
	Air leak due to bad seals, gaskets or pipe connections.	Replace seals, check inlet fittings.

PROBLEM	POSSIBLE CAUSE	POSSIBLE SOLUTIONS
<b>Fluid vaporization causing “starved” pump inlet</b>	Strainers, foot valves, inlet fittings or lines clogged.	Clear lines. If problem continues, inlet system may require changing.
	Inlet line size too small, inlet line too long. Too many fittings or valves. Foot valve, strainers too small.	Increase inlet line size. Reduce length, minimize direction and size changes, reduce number of fittings.
	NIPA (Net Inlet Pressure Available) at pump is too low.	Raise liquid level in source tank to increase NIPA.  Increase NIPA at pump by raising or pressurizing source tank.
	Fluid viscosity greater than expected.	Select larger pump size with lower NIPR (Net Inlet Pressure Required).  Reduce pump speed and accept lower flow, or change system to reduce line losses.  Increase temperature of product to reduce viscosity.
<b>Insufficient flow. Flow bypassed.</b>	Fluid temperature higher than expected (vapor pressure higher).	Reduce temperature, reduce speed and accept lower flow or change system to increase NIPA.
	Flow diverted in branch line, open valve, etc.  Relief valve jammed or not adjusted.	Check system and controls.  Clear or adjust valve.
<b>Insufficient flow. High slip.</b>	Hot (HC) or extra clearance rotors on cold fluid, and/or low viscosity fluid.	Replace with standard clearance rotors.
	Worn pump.	Increase pump speed (within limits). Replace rotors.
	High pressure.	Reduce pressure by adjusting system settings or hardware.
<b>Noisy operation caused by fluid.</b>	Cavitation due to high fluid viscosity. High vapor pressure fluid. High temperature.	Slow pump speed, reduce temperature, change system setup.
	Cavitation due to NIPA (Net Inlet Pressure Available) less than NIPR (Net Inlet Pressure Required).	Increase NIPA, or reduce NIPR.
	Air or gas in fluid caused by leaks in piping.	Check system and fix leaks.
	Air or gas in fluid caused by dissolved gas or naturally aerated products.	Minimize discharge pressure (also see Cavitation).
<b>Noisy operation caused by installation.</b>	Line size too small. Too many elbows.	Increase line size. Remove elbows.
	Malfunction or incorrect sizing of devices, such as valves.	Correctly size all system devices and keep in good working order.

PROBLEM	POSSIBLE CAUSE	POSSIBLE SOLUTIONS
<b>Noisy operation caused by mechanical problems.</b>	Rotor to body contact due to improper assembly of pump.	Check clearances and adjust shimming.
	Rotor to body contact caused by distortion of pump due to improper piping installation.	Change piping installation to eliminate piping stress and distortion on body.
	Pressures required higher than the pump is rated for.	Reduce discharge pressure required.
	Rotor to body contact caused by worn bearings.	Rebuild with new bearings and lubricate regularly.
	Rotor to rotor contact caused by loose or incorrectly timed gears.	This has caused severe damage to components - rebuild with new parts.
	Rotor to rotor contact caused by sheared keys.	This has caused severe damage to components - rebuild with new parts.
	Rotor to rotor contact caused by worn gear splines.	This has caused severe damage to components - rebuild with new parts.
Drive noise caused by gear trains, chains, couplings, bearings.	Repair or replace drive parts. Check bearings for damage and replace as necessary.	
<b>Pump requires excessive power (over heats, stalls, high current draw, breakers trip).</b>	Higher than expected viscosity losses.	If within pump rating, increase drive size.
	Higher than expected pressures.	Reduce pump speed. Increase line sizes.
	Fluid is colder with a higher viscosity than expected.	Heat fluid, insulate lines or heat trace lines. Increase line sizes.
	Fluid sets in line and pump during shutdown.	Insulate lines or heat trace lines.
	Fluid builds up on pump surfaces.	Install a "soft start" drive. Install a recirculating bypass system. Flush system with a nonsetting fluid.
	Fluid builds up on pump surfaces.	Replace pump with more running clearances.
<b>Short pump service life.</b>	Pumping abrasives.	Larger pumps at slower speeds.
	Speeds and pressures higher than rated.	Reduce speeds and pressures by making changes in system.  Replace pump with a larger model with higher pressure ratings.
	Worn bearings and gears due to lack of lubrication.	Check and replace bearings and gears as necessary. Adjust lubrication schedule.
	Misalignment of drive and piping. (Excessive over hung load or misaligned couplings.)	Check alignment of piping and drive. Adjust as necessary.
	Corrosion.	Contact WCB Application Engineering.





# **SPX** Process Equipment

611 Sugar Creek Road • Delavan, WI 53115 USA

Tel: (800) 252-5200 or (262) 728-1900 • Fax: (800) 252-5012 or (262) 728-4904

E-mail: [info@processequipment.spx.com](mailto:info@processequipment.spx.com) • Web site: [www.spxprocessequipment.com](http://www.spxprocessequipment.com)

Issued: April 2004 • Revised: February 2005

95-03056