

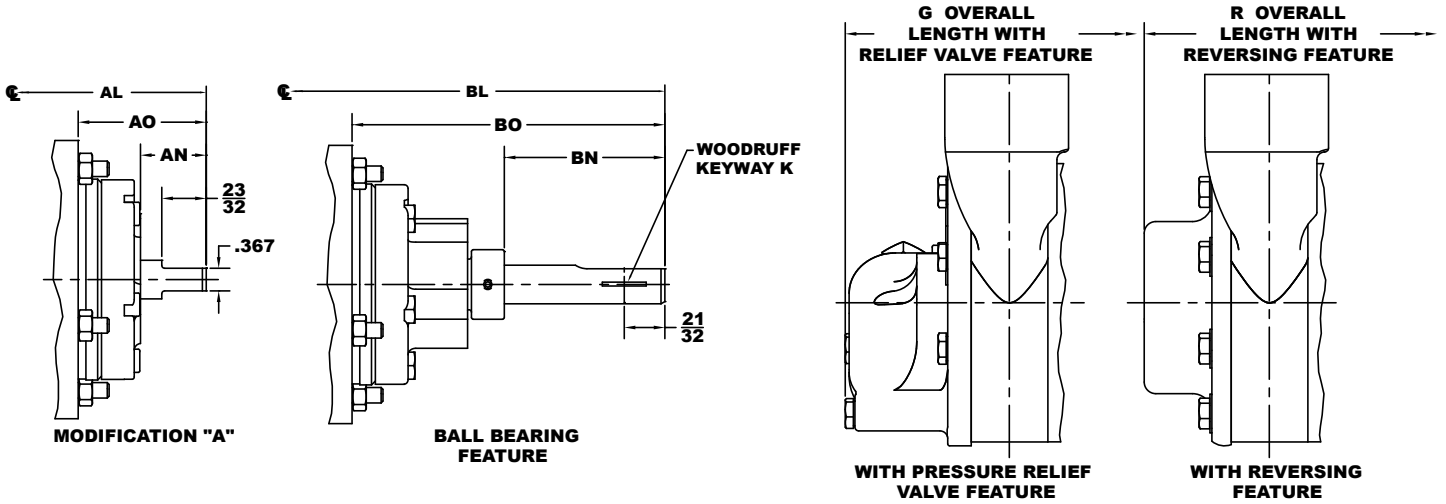
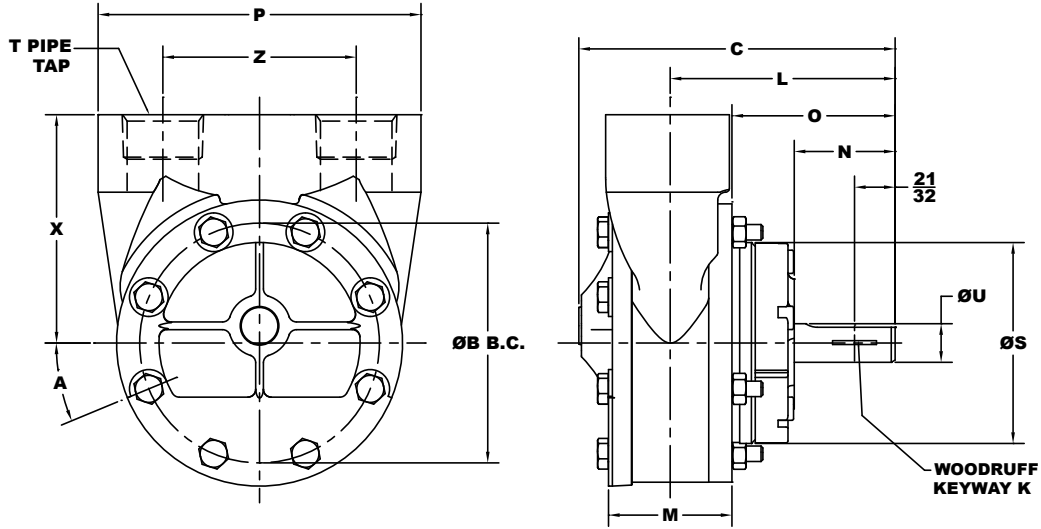

Table of Contents

Product Overview.....	3	Dimensions for C Series Mounting Feet (2C81, 3C81, 3CK81 & 5C81).....	17
C2F Features.....	3	4310 Pump Mounting Dimensions.....	18
C2E Features.....	3	4300 Pump Model Number System.....	19
C2B/4310 Features.....	3	4300 Series Port Sizes.....	19
CK2B Features.....	3	4300 Pump Temperature Limits.....	19
C2FA Features.....	3	4300 Pump Materials of Construction.....	20
C2S/C2SA Features.....	3	4000/C Cross Reference List.....	20
CC Features.....	3	CC09 Pump/NEMA Motor Mounting Dimensions.....	21
C2F Pump.....	4	CC015, 020 & 030 Pump/NEMA Motor Mounting Dimensions.....	22
C2E Pump Mounting Dimensions.....	5	CC Pump Model Number System.....	23
C2B Pump Mounting Dimensions.....	6	CC Pump Temperature Limits.....	23
CK2B Pump Mounting Dimensions.....	7	CC Pump Materials of Construction.....	23
C2FA Pump Mounting Dimensions.....	8	CC Pump NPSH Data.....	24
C2S Mounting Dimensions.....	9	Viscosity Correction Factor.....	24
C2SA Pump Mounting Dimensions.....	10		
C Pump Model Number System.....	11		
C Pump Temperature Limits.....	12		
C Pump Materials of Construction.....	12		
C Pump NPSH Data.....	12		
Viscosity Correction Factor.....	12		
Dimensions for 2CF Close Coupled Pumps to Three Phase Motors.....	13		
Dimensions for Adapter Mounting 2CF Pumps to NEMA C Frame Motors.....	14		
Dimensions for Adapter Mounting C2B & 4300 Pumps to NEMA C Frame Motors.....	15		
Dimensions for Adapter Mounting CK2B Pumps to NEMA C Frame Motors.....	16		

Product Overview	
Positive Displacement Internal Rotary Gear Design Cast Iron Construction with NPT Top Ports Five Sizes from 3 - 84 GPM Typical Viscosity Range is 40 - 10,000 SSU Temperatures to 375 °F	
C2F Features	Options
Flange Mount Configuration Spring Loaded Viton Lip Seal Inlet Pressure to 25 PSI Discharge Pressure to 100 PSI Maximum Differential Pressure to 100 PSI	Internal Relief Valve and Outboard Ball Bearing Reversing Feature and SAE Porting Adapter Kit for NEMA C Face Ports Shaft Modification for Close Coupled Mounting
C2E Features	Options
Foot Mounted Configuration Spring Loaded Viton Lip Seal Inlet Pressure to 25 PSI Discharge Pressure to 100 PSI Maximum Differential Pressure to 100 PSI	Internal Relief Valve and Outboard Ball Bearing Reversing Feature and SAE Porting
C2B/4310 Features	Options
Flange Mount Configuration Viton Mechanical Seal Inlet Pressure to 250 PSI Discharge Pressure to 300 PSI Maximum Differential Pressure to 150 PSI	Seal Elastomer (Neoprene/EPR) Internal Relief Valve and Outboard Ball Bearing Reversing Feature and SAE Porting Mounting Foot for Direct Drive Adapter Kit for NEMA C Face Mounting
CK2B Features	Options
Flange Mount Configuration Viton Mechanical Seal Double Ball Bearing with an Inboard Heavy-Duty Roller Bearing Inlet Pressure to 250 PSI Discharge Pressure to 300 PSI Maximum Differential Pressure to 250 PSI	Seal Elastomer - Neoprene or EPR Internal Relief Valve and Reversing Feature Mounting Foot for Direct Drive Adapter Kit for NEMA C Face Mounting
C2FA Features	Options
Flange Mount Configuration Seal-less Design for OEM Built-In Applications Inlet Pressure to 25 PSI Discharge Pressure to 100 PSI Maximum Differential Pressure to 100 PSI	Internal Relief Valve Outboard Ball Bearing Reversing Feature SAE Porting Tang Shaft Modification
C2S/C2SA Features	CC Features
Incomplete "Stripped" Configurations for OEM Built-In Applications C2S Consists of Cover, Housing, Idler Gear, & Rotor C2SA Consists of Cover, Idler Gear, & Rotor Reversing Feature	Flange Mount Configuration Directly to NEMA 56 C, 143/145 TC Motor Viton Mechanical Seal Inlet Pressure to 25 PSI Discharge Pressure to 125 PSI Maximum Differential Pressure to 100 PSI Optional Relief Valve

C2F Pump



Model	A	B	C	R	G	K	L	M	N	O	P	S
2C2F	22 1/2°	3 7/8	5 1/8	5 21/32	6 7/32	#406	3 5/8	2	1 5/8	2 5/8	5 7/32	3 1/4
3C2F	22 1/2°	5 1/8	6 17/32	6 7/8	7 17/32	#606	4 13/16	2 5/16	2 3/32	3 7/16	6 5/8	3 3/4
4C2F	22 1/2°	5 1/8	7 27/32	7 9/16	8 7/32	#606	4 29/32	3	2 3/32	3 7/16	6 1/2	3 3/4
5C2F	17°	6 5/8	9 1/16	11 5/8	10 1/4	#808	5 3/4	4 5/16	2 3/8	3 3/8	7 1/2	3 3/4
6C2F	17°	6 5/8	9 1/2	12 1/8	10 3/4	#808	6	4 13/16	2 3/8	3 3/8	8 1/8	3 3/4

Model	T	U	X	Z	AL	AN	AO	BL	BN	BO
2C2F	1" NPT	5/8	3 11/16	3 1/8	3 1/16	1 1/16	2 1/16	6 1/16	2 19/32	5 1/32
3C2F	1 1/4" NPT	3/4	4 7/8	4 1/8	3 7/16	23/32	2 1/16	6 13/16	2 25/32	5 7/16
4C2F	1 1/2" NPT	3/4	4 1/8	3 3/4	3 17/32	23/32	2 1/16	6 29/32	2 25/32	5 7/16
5C2F	1 1/2" NPT	1	5	4 3/4	4 1/4	7/8	1 7/8	6 7/8	1 29/32	4 1/2
6C2F	2" NPT	1	4 3/4	4 3/4	4 1/2	7/8	1 7/8	7 1/8	1 29/32	4 1/2

C2E Pump Mounting Dimensions

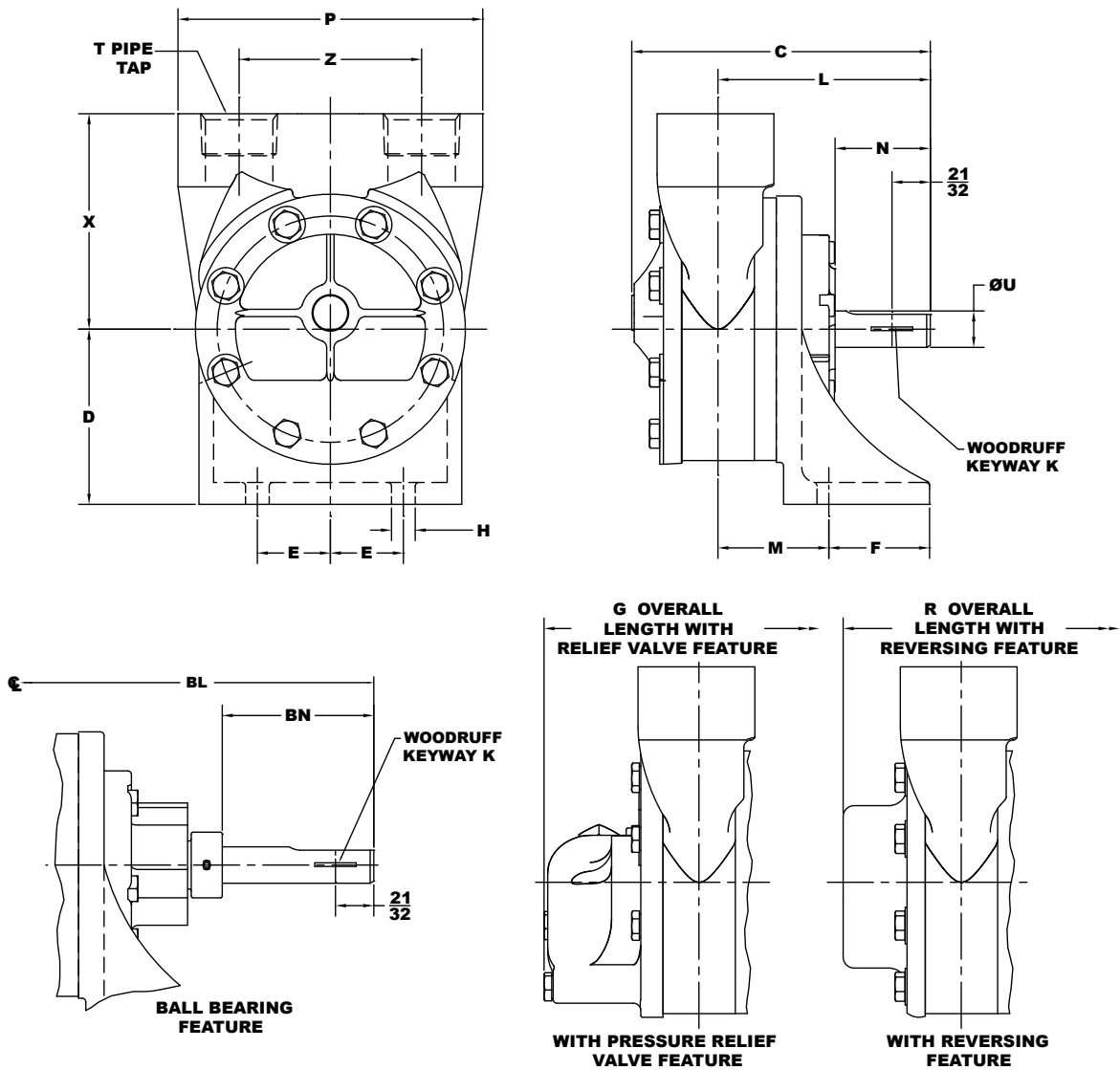

Model	C	R	G	D	E	F	H	K	L	M	N	P
2C2E	5 1/8	5 21/32	6 7/32	3	1 1/4	1 19/32	13/32	#406	3 5/8	1 29/32	1 5/8	5 7/32
3C2E	6 17/32	6 7/8	7 17/32	3 7/8	1 1/2	SLOT	15/32	#606	4 13/16	SLOT	2 3/32	6 5/8
4C2E	7 27/32	7 9/16	8 7/32	3 7/8	1 1/2	SLOT	15/32	#606	4 29/32	SLOT	2 3/32	6 1/2
5C2E	10 3/16	12 3/4	11 3/8	4 3/4	1 1/2	SLOT	15/32	#808	6 7/8	SLOT	3 1/2	7 1/2
6C2E	10 5/8	13 1/4	11 7/8	4 3/4	1 1/2	SLOT	15/32	#808	7 1/8	SLOT	3 1/2	8 1/8

Model	T	U	X	Z	BL	BN
2C2E	1" NPT	5/8	3 11/16	3 1/8	6 1/6	2 19/32
3C2E	1 1/4" NPT	3/4	4 7/8	4 1/8	6 13/16	2 25/32
4C2E	1 1/2" NPT	3/4	4 1/8	3 3/4	6 29/32	2 25/32
5C2E	1 1/2" NPT	1	5	4 3/4	6 7/8	1 29/32
6C2E	2" NPT	1	4 3/4	4 3/4	7 1/8	1 29/32

C2B Pump Mounting Dimensions

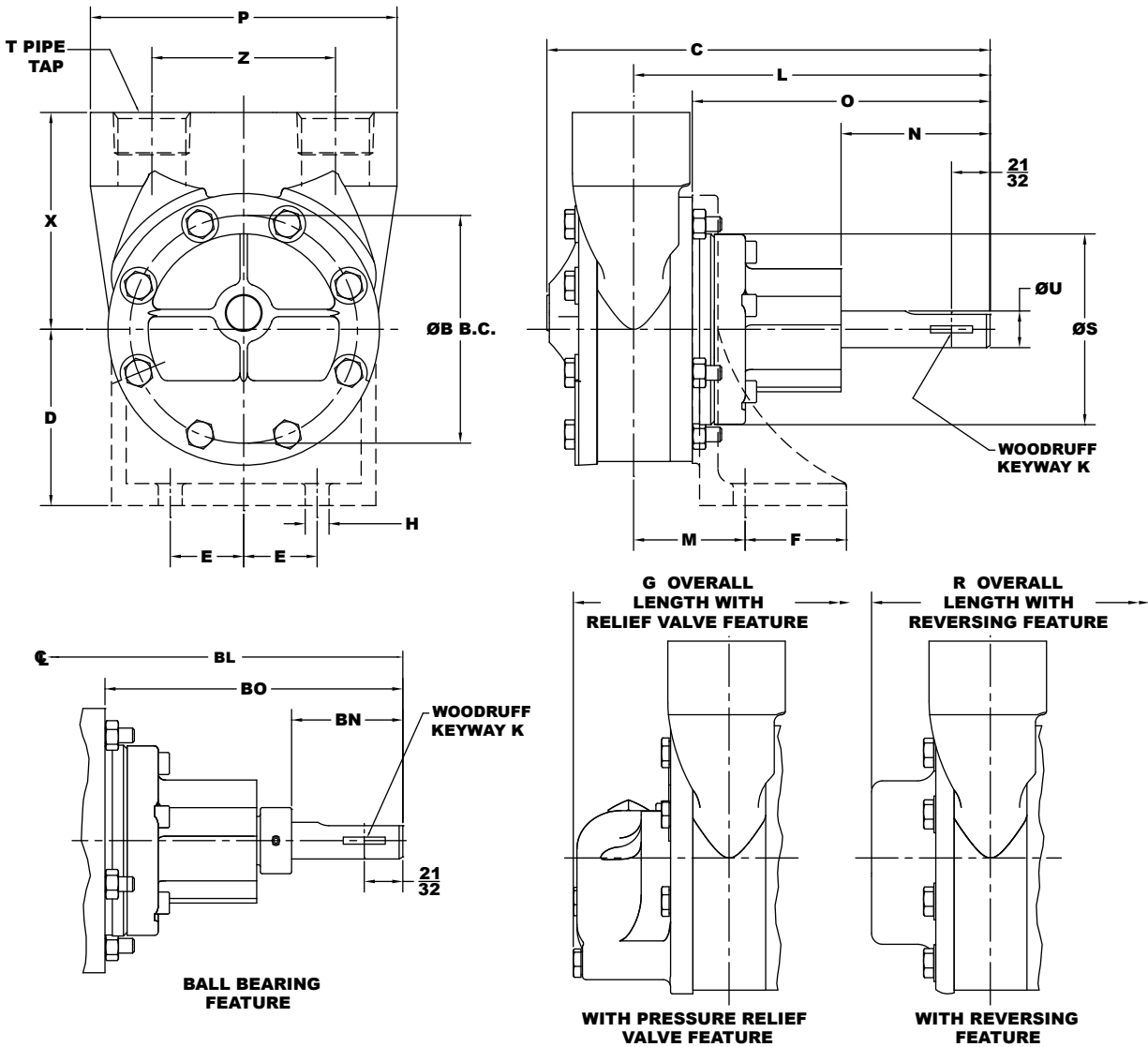

Model	C	B	R	G	D	E	F	H	K	L	M	N
2C2B	7 9/16	3 7/8	8 3/32	8 21/32	3	1 1/4	1 19/32	13/32	#406	6 1/16	1 29/32	2 17/32
3C2B	8 17/32	5 1/8	8 7/8	9 17/32	3 7/8	1 1/2	SLOT	15/32	#606	6 13/16	SLOT	2 1/2
4C2B	9 27/32	5 1/8	9 9/16	10 7/32	3 7/8	1 1/2	SLOT	15/32	#606	6 29/32	SLOT	2 1/2
5C2B	11 15/16	6 5/8	14 1/2	13 1/8	4 3/4	1 1/2	SLOT	15/32	#808	8 5/8	SLOT	3 13/32
6C2B	12 3/8	6 5/8	15	13 5/8	4 3/4	1 1/2	SLOT	15/32	#808	8 7/8	SLOT	3 13/32

Model	O	P	S	T	U	X	Z	BL	BN	BO
2C2B	5 1/16	5 7/32	3 1/4	1" NPT	5/8	3 11/16	3 1/8	6 1/16	1 27/32	5 1/16
3C2B	5 7/16	6 5/8	3 3/4	1 1/4" NPT	3/4	4 7/8	4 1/8	6 13/16	1 25/32	5 7/16
4C2B	5 7/16	6 1/2	3 3/4	1 1/2" NPT	3/4	4 1/8	3 3/4	6 29/32	1 25/32	5 7/16
5C2B	6 1/4	7 1/2	3 3/4	1 1/2" NPT	1	5	4 3/4	8 5/8	2 9/16	6 1/4
6C2B	6 1/4	8 1/8	3 3/4	2" NPT	1	4 3/4	4 3/4	8 7/8	2 9/16	6 1/4

CK2B Pump Mounting Dimensions

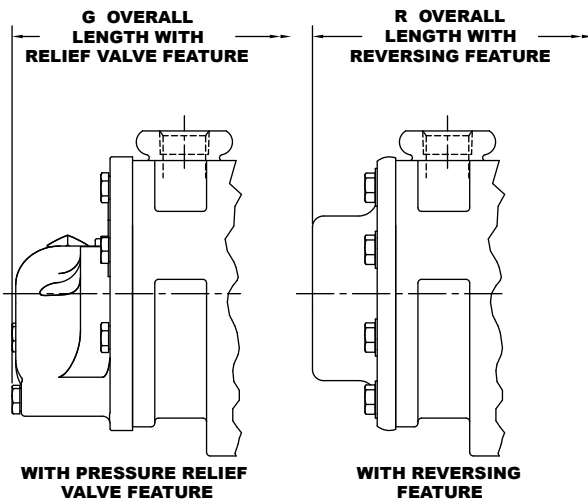
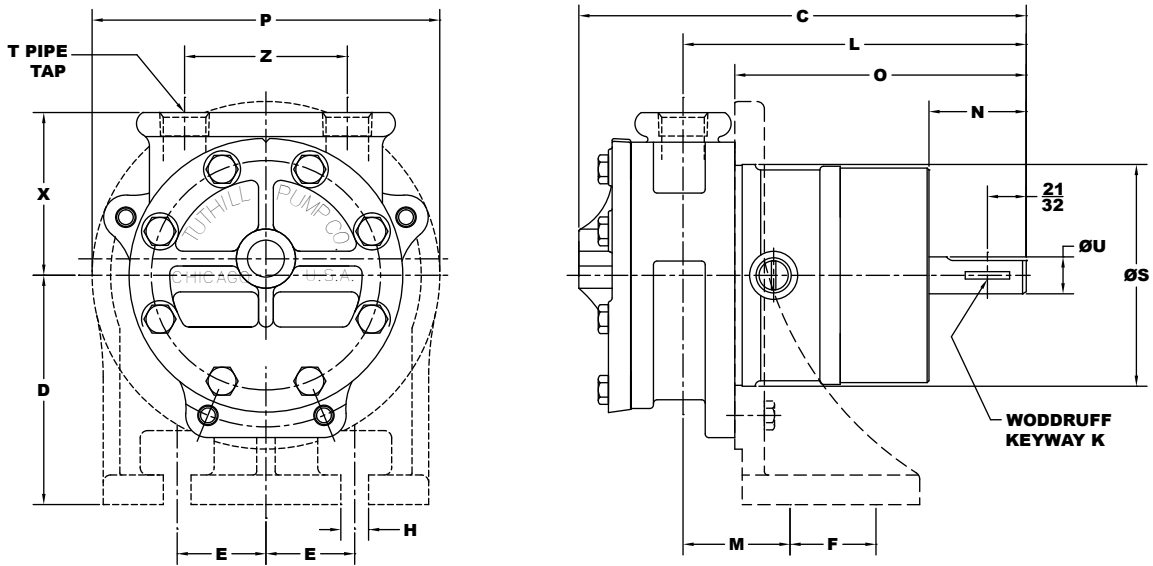

Model	C	R	G	D	E	F	H	K	L	M	N	O
2CK2B	7 9/16	8 1/16	8 21/32	3 7/8	1 1/2	SLOT	15/32	#406	5 13/16	SLOT	1 5/8	4 15/16
4CK2B	9 27/32	9 9/16	10 7/32	3 7/8	1 1/2	SLOT	15/32	#606	6 13/16	SLOT	1 5/8	5 5/8
6CK2B	12 3/8	15	13 5/8	4 3/4	1 1/2	SLOT	15/32	#808	8 9/16	SLOT	2	6 13/16
Model	P	S	T	U	X	Z						
2CK2B	5 7/8	3 3/4	1/2" NPT	5/8	2 3/4	2 3/4						
4CK2B	6	3 3/4	1" NPT	3/4	3 5/8	3 3/4						
6CK2B	8 1/8	3 3/4	2" NPT	1	4 3/4	4 3/4						

C2FA Pump Mounting Dimensions

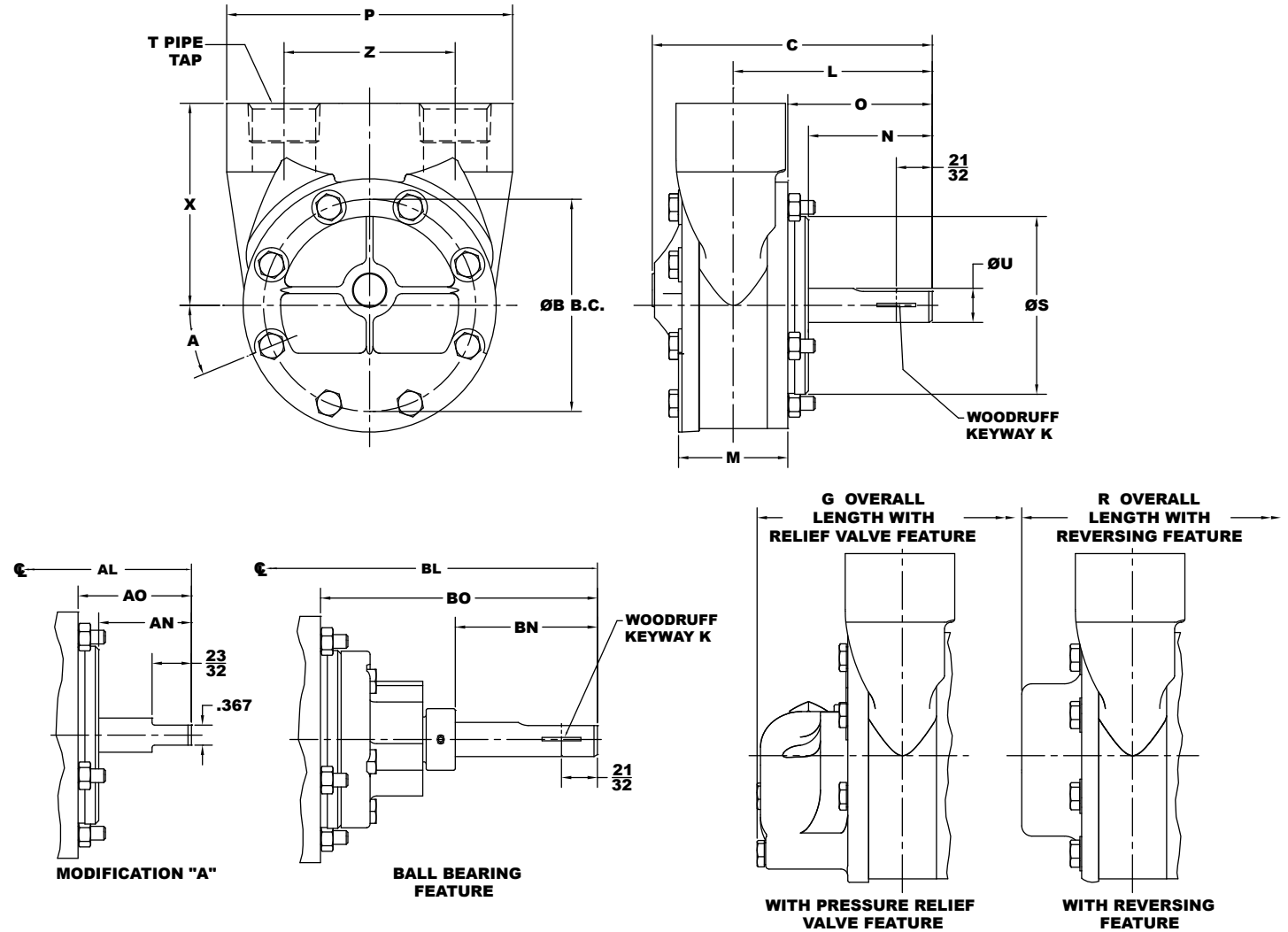

Model	A	B	C	R	G	K	L	M	N	O	P	S
2C2FA	22 1/2°	3 7/8	5 1/8	5 21/32	6 7/32	#406	3 5/8	2	2 1/8	2 5/8	5 7/32	3 1/4
3C2FA	22 1/2°	5 1/8	6 17/32	6 7/8	7 17/32	#606	4 13/16	2 5/16	2 19/32	3 7/16	6 5/8	3 3/4
4C2FA	22 1/2°	5 1/8	7 27/32	7 9/16	8 7/32	#606	4 29/32	3	2 19/32	3 7/16	6 1/2	3 3/4
5C2FA	17°	6 5/8	9 1/16	11 5/8	10 1/4	#808	5 3/4	4 5/16	2 3/4	3 3/8	7 1/2	3 3/4
6C2FA	17°	6 5/8	9 1/2	12 1/8	10 3/4	#808	6	4 13/16	2 3/4	3 3/8	8 1/8	3 3/4

Model	T	U	X	Z	AL	AN	AO	BL	BN	BO
2C2FA	1" NPT	5/8	3 11/16	3 1/8	3 1/16	1 9/16	2 1/16	6 1/16	2 19/32	5 1/32
3C2FA	1 1/4" NPT	3/4	4 7/8	4 1/8	3 7/16	1 7/32	2 1/16	6 13/16	2 25/32	5 7/16
4C2FA	1 1/2" NPT	3/4	4 1/8	3 3/4	3 17/32	1 7/32	2 1/16	6 29/32	2 25/32	5 7/16
5C2FA	1 1/2" NPT	1	5	4 3/4	4 1/4	1 1/4	1 7/8	6 7/8	1 29/32	4 1/2
6C2FA	2" NPT	1	4 3/4	4 3/4	4 1/2	1 1/4	1 7/8	7 1/8	1 29/32	4 1/2

C2S Mounting Dimensions

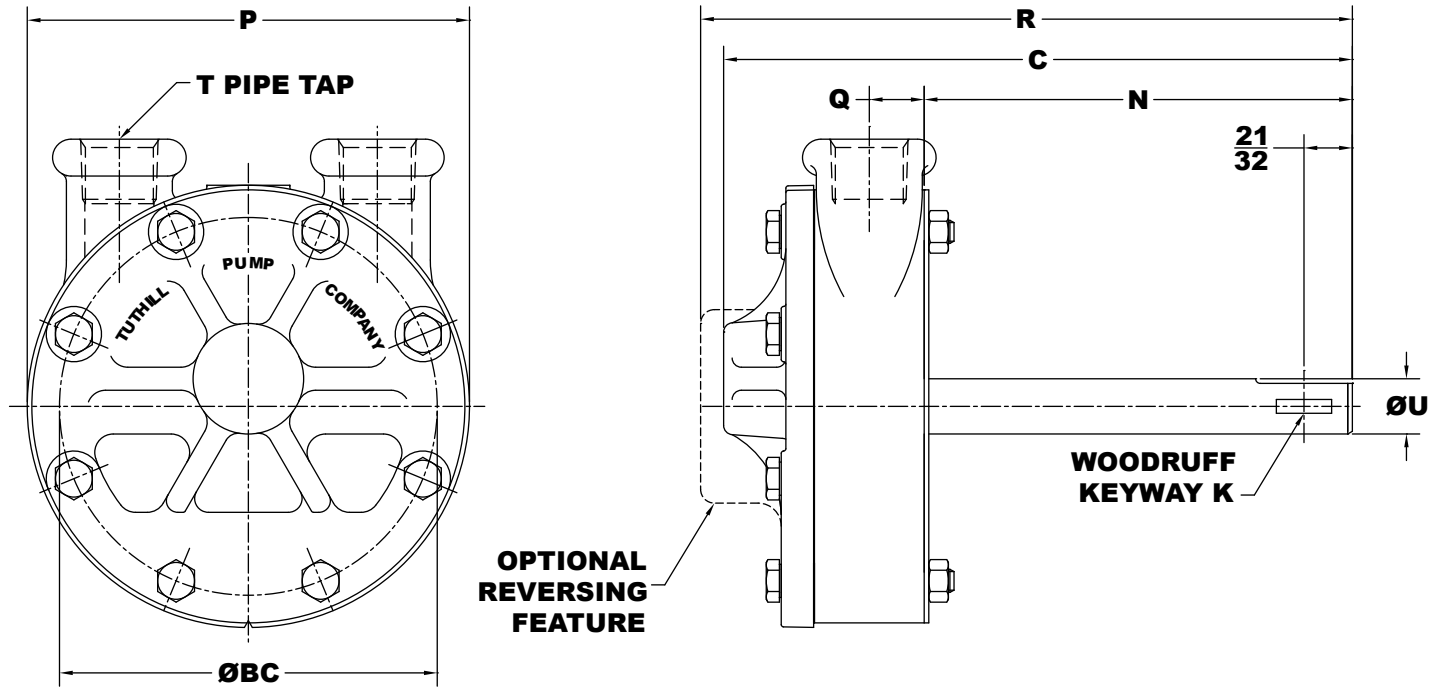

Model	BC	C	R	K	N	P	Q	T	U
1ACS	2 7/8	6 1/8	6 1/2	#204	4 3/8	3 1/2	1/2	3/8" NPT	<u>.499</u> .498
2CS	3 7/8	7 9/16	8 1/16	#406	5 7/16	4 5/8	5/8	1/2" NPT	<u>.624</u> .623
3CS	5 1/8	8 1/2	8 7/8	#606	5 13/16	6	3/4	3/4" NPT	<u>.749</u> .748
4CS	5 1/8	9 1/4	9 9/16	#606	5 13/16	6	1 1/4	1" NPT	<u>.749</u> .748
5CS	6 5/8	11 7/8	14 1/2	#808	7 1/4	7 1/2	1 3/8	1 1/4" NPT	<u>.999</u> .998
6ACS	6 5/8	12 3/8	15	#808	7 1/4	7 1/2	1 5/8	2" NPT	<u>.999</u> .998

C2SA Pump Mounting Dimensions

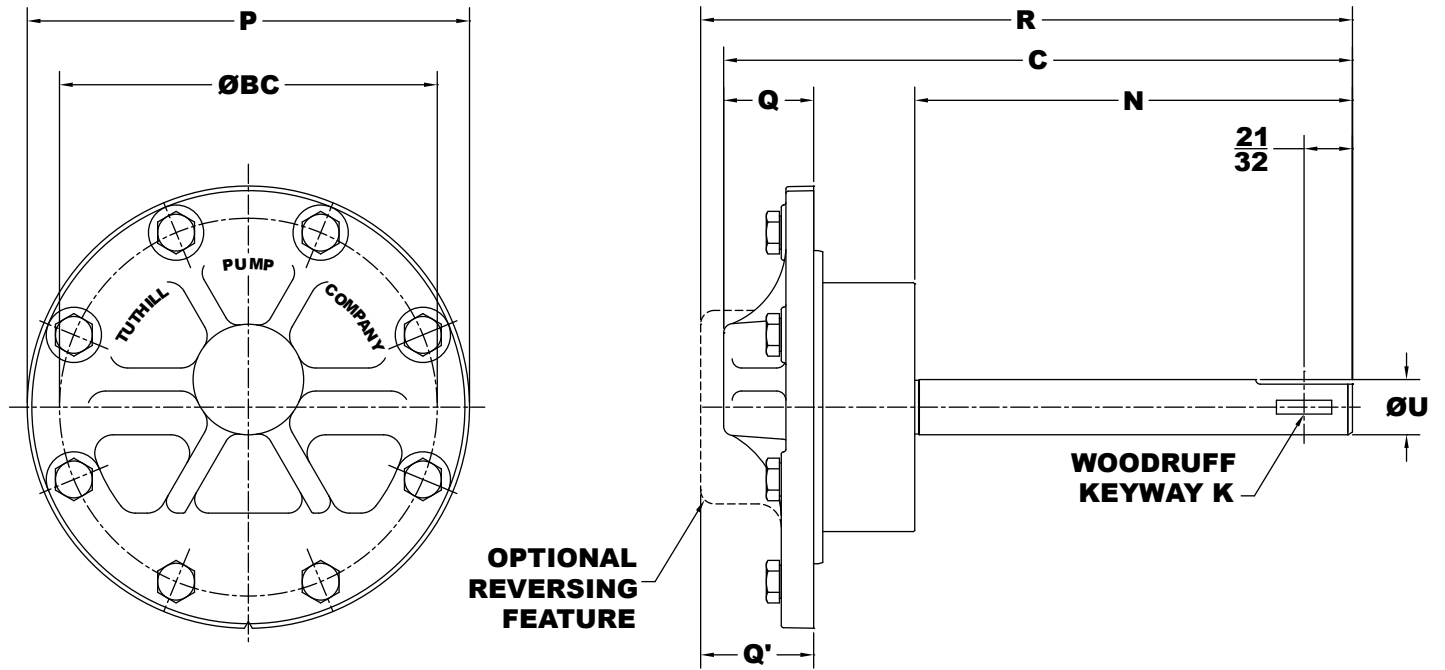

Model	BC	C	R	K	N	P	Q	Q'	U
1CSA	2 7/8	6 1/8	6 1/2	#204	4 1/2	3 1/2	11/16	1 1/8	<u>.499</u> .498
2CSA	3 7/8	7 9/16	8 1/16	#406	5 9/16	4 5/8	3/4	1 5/16	<u>.624</u> .623
3CSA	5 1/8	8 1/2	8 7/8	#606	5 15/16	6	1 1/4	1 11/16	<u>.749</u> .748
4CSA	5 1/8	9 1/4	9 9/16	#606	5 15/16	6	1 7/8	1 11/16	<u>.749</u> .748
5CSA	6 5/8	11 7/8	14 1/2	#808	7 7/16	7 1/2	1 15/16	4 1/2	<u>.999</u> .998
6CSA	6 5/8	12 3/8	15	#808	7 7/16	7 1/2	1 15/16	4 1/2	<u>.999</u> .998

C Pump Model Number System

Position #	Size	Reversing Feature	Model				Pump Options	Rotation		Modifications				SAE Port Option		
	1	2	3	4	5	6	7	8	9	10	11	12	13	14	15	16

Position #	Description	Codes
1	Size	-2, -3, -4, -5, or -6
2	Reversing Feature	-R
3, 4, 5, & 6	Model	-C2F, -C2FA, -C2E, -C2B, CK2B
7	Pump Options	-V = Valve, -N = Outboard Ball Bearing, or -U = Cover Rotated 180°
8 & 9	Rotation	-C = Clockwise Rotation or -CC = Counterclockwise
	Suction Port Location on Pumps w/ Reversing Feature	-RH = Right Hand Suction or -LH = Left Hand Suction
10, 11, 12, 13, & 14	Modifications	-A = Tang Shaft(C2F/C2FA), -5 = Neoprene Seal(C2B/CK2B), -7 = Viton Seal, -78910 = Abrasion Resistant Viton Seal, -8 = EPR Seal(C2B/CK2B), -N = No Flat/Keyway in Shaft
15, 16, & 17	SAE Port Option	-SAE (-NPT is Standard)

Note: -CK1B, C2SA, C2S no longer available for purchase.

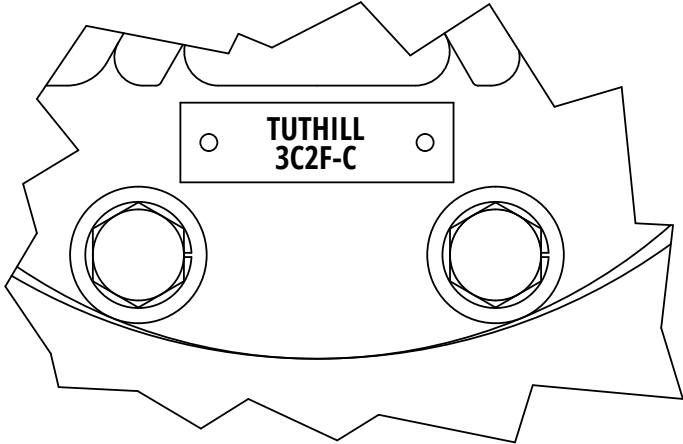
Port		Pump Size					Model Number is Stamped on a Metal Tag on the Cover
Style	Size	2	3	4	5	6	
NPT	1"	STD.	-	-	-	-	
	1 1/4"	-	STD.	-	-	-	
	1 1/2"	-	-	STD.	STD.	-	
	2"	-	-	-	-	STD.	
SAE	16	OPT.	-	-	-	-	
	20	-	OPT.	OPT.	-	-	
	24	-	-	-	OPT.	-	
	32	-	-	-	-	OPT.	

C Pump Temperature Limits

Material	Minimum	Maximum	Material	Minimum	Maximum
Bronze Bushing	-100 °F	400 °F	Neoprene	-40 °F	200 °F
Carbon Bushing	-100 °F	500 °F	Ethylene Propylene (EPR)	-40 °F	300 °F
Viton	-10 °F	375 °F			

Notes: A pump's performance is dependent on more than just the temperature ranges of the component materials.

C Pump Materials of Construction

Part Name	Material	Standard	Comments	Availability
Housing	Cast Iron	ASTM A48 - 96a	Classes 30, 35, or 40	Std.
Bracket	Cast Iron	ASTM A48 - 96a	Classes 30, 35, or 40	Std.
Bracket Bushing	Bronze	SAE 660		Std.
Cover	Cast Iron	ASTM A48 - 96a	Classes 30, 35, or 40	Std.
Rotor	Steel	C1137 or C1141	Steel Forging	Std.
Idler	P/M Steel	FC-0508-P		Std.
	Steel	C1117		Opt.
Idler Pin	Steel	C1117	Heat Treated	Std.
Idler Bushing	Bronze	SAE		Std.
Seal Gland	Cast Iron	ASTM A48 - 96a	Classes 30, 35, or 40	Std.
	DU Bushing		Only on C2B models	
O-Rings & Seal	Viton			Std.
	Neoprene			Opt.
	EPR			Opt.

C Pump NPSH Data

NPSH Required for Tuthill "C" Pumps 0 - 1000 SSU

Pump Series	NPSH (Units)	300 RPM	600 RPM	900 RPM	1200 RPM	1500 RPM	1800 RPM
2	FT.	1.2	2.0	2.8	3.8	5.1	6.6
3	FT.	1.4	2.4	3.6	5.2	7.1	9.4
4	FT.	1.6	2.7	4.4	6.5	9.1	12.2
5	FT.	1.8	3.0	5.2	8.2	11.9	16.2
6	FT.	2.0	3.3	6.0	9.9	14.8	20.1

Viscosity Correction Factor

2500 SSU	5000 SSU	10000 SSU	25000 SSU
1.3 Correction Factor	1.7 Correction Factor	2.0 Correction Factor	2.7 Correction Factor

Dimensions for 2CF Close Coupled Pumps to Three Phase Motors

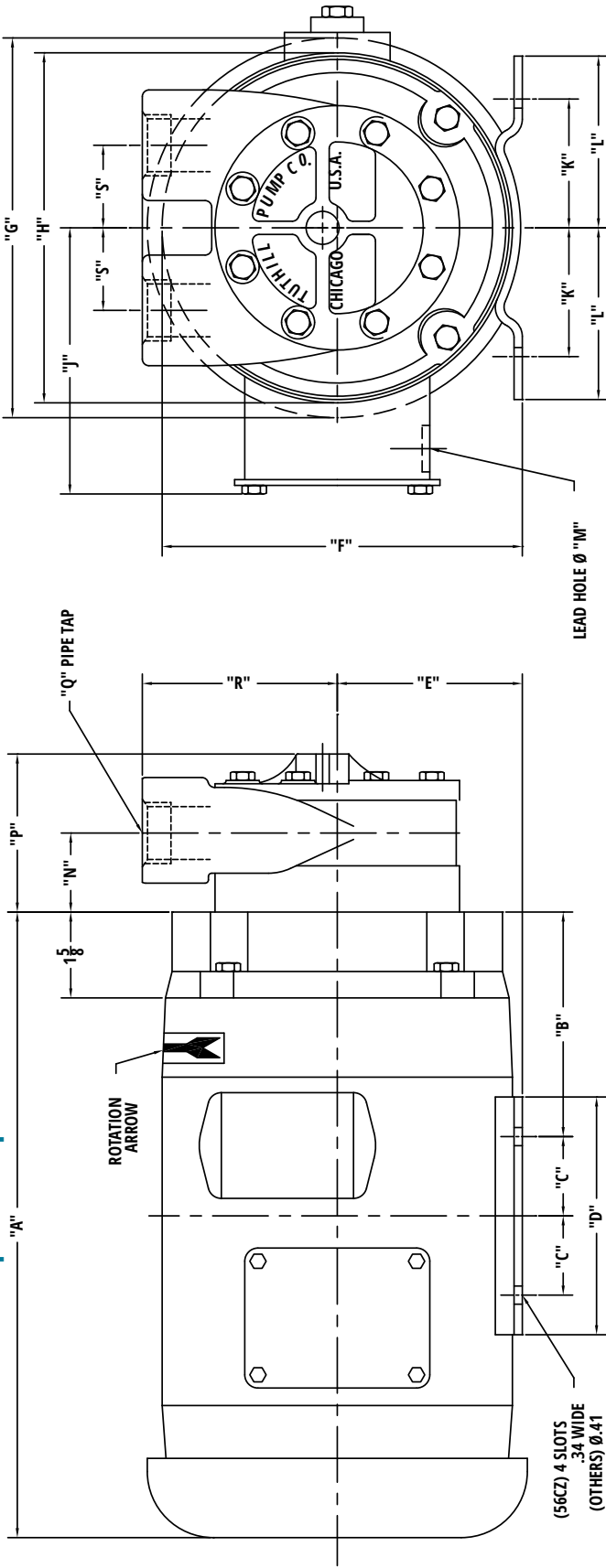

MODEL #	"N"	"P"	"R"	"S"	"Q" - NPT
2CF	1 1/32	2 17/32	3 11/16	1 9/16	1-11 1/2
3CF	1 3/8	3 3/32	4 7/8	2 1/16	1 1/4-11 1/2
4CF	1 15/32	4 13/32	4 1/8	1 7/8	1 1/2-11 1/2

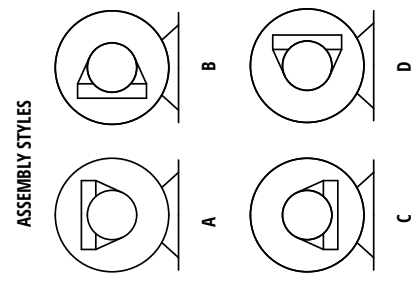

MODEL #	HP	DESCRIPTION	"A"	"B"	"C"	"D"	"E"	"F"	"G"	"H"	"J"	"K"	"L"	"M"	WT.
88501	3/4	3PH/50/60/190/380/220/440 VOLT, 208-220/440 VOLT, 1425/1125 RPM, TEFC, 56CZ FRAME	11.81	4.20	1.50	4.50	3.50	6.81	7.16	6.62	5.22	2.44	3.25	.88	26
88502	3/4	3PH/50/60/190/380/220/440 VOLT, 208-220/440 VOLT, 950/1125 RPM, TEFC, 56CZ FRAME	12.81	4.20	1.50	4.50	3.50	6.81	7.16	6.62	5.22	2.44	3.25	.88	35
88503	1	3PH/50/60/190/380/220/440 VOLT, 208-220/440 VOLT, 1425/1125 RPM, TEFC, 56CZ FRAME	11.81	4.20	1.50	4.50	3.50	6.81	7.16	6.62	5.22	2.44	3.25	.88	28
88504	1	3PH/50/60/190/380/220/440 VOLT, 208-220/440 VOLT, 950/1125 RPM, TEFC, 184CZ FRAME	13.81	4.25	2.75	6.50	4.50	8.44	8.50	7.88	5.97	3.75	4.31	1.09	50
88505	1 1/2	3PH/50/60/190/380/220/440 VOLT, 208-220/440 VOLT, 1425/1125 RPM, TEFC, 184CZ FRAME	13.81	4.25	2.75	6.50	4.50	8.44	8.50	7.88	5.97	3.75	4.31	1.09	51
88506	1 1/2	3PH/50/60/190/380/220/440 VOLT, 208-220/440 VOLT, 950/1125 RPM, TEFC, 184CZ FRAME	15.19	4.25	2.75	6.50	4.50	8.44	8.50	7.88	5.97	3.75	4.31	1.09	57
88507	2	3PH/50/60/190/380/220/440 VOLT, 208-220/440 VOLT, 1425/1125 RPM, TEFC, 184CZ FRAME	13.81	4.25	2.75	6.50	4.50	8.44	8.50	7.88	6.00	3.75	4.31	1.09	55
88493	2	3PH/50/60/190/380/220/440 VOLT, 208-220/440 VOLT, 950/1125 RPM, TEFC, 213CZ FRAME	16.68	4.88	2.75	6.50	5.25	9.16	8.50	7.88	5.97	4.25	4.75	1.06	71
88508	3	3PH/50/60/190/380/220/440 VOLT, 208-220/440 VOLT, 1425/1125 RPM, TEFC, 213CZ FRAME	15.18	4.88	2.75	6.50	5.25	9.16	8.50	7.88	5.97	4.25	4.75	1.06	55
88509	3	3PH/50/60/190/380/220/440 VOLT, 208-220/440 VOLT, 950/1125 RPM, TEFC, 215CZ FRAME	16.03	4.25	3.50	8.00	5.25	10.03	10.62	9.56	7.46	4.25	4.75	1.09	71

Dimensions for Adapter Mounting 2CF Pumps to NEMA C Frame Motors

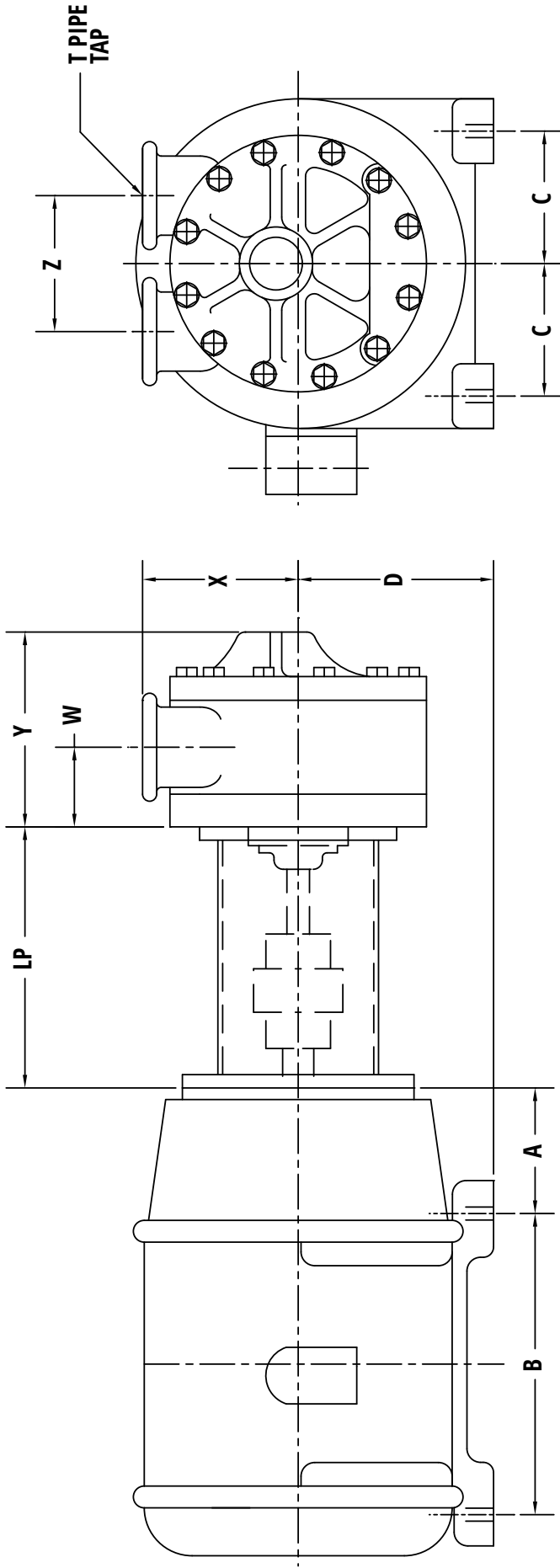

Pump Model	Motor Frame Size	LP	Adapter Kit	Adapter	Motor Frame	A	B	C	D	Pump Model	T	W	X	Y	Y Dim with Relief Valve	Z
2CF	56C	5 11/16	2CF534	2CF51	56C	2 3/4	3	2 7/16	3 1/2	2CF	1" NPT	1	3	2 1/2	3 19/32	3 1/8
	143TC, 145TC	5 11/16	2CF534A	2CF51	143TC	2 1/4	4	2 3/4	3 1/2	3CF	1 1/4" NPT	1 3/8	11/16	3 3/32	4 3/32	4 1/8
	182TC, 184TC	6 1/8	2C1F534-182	2C1F51-182	182TC	2 3/4	4 1/2	3 3/4	4 1/2	4CF	1 1/2" NPT	1 15/32	4 1/8	4 13/32	5 13/32	3 3/4
3CF	56C	6 1/4	3CF534	3CF51	56C	2 3/4	5	2 3/4	3 1/2	2CF	1 1/4" NPT	1 3/8	3	2 1/2	3 19/32	3 1/8
	143TC, 145TC	6 1/4	3CF534A	3CF51	143TC	2 1/4	4	2 3/4	3 1/2	3CF	1 1/4" NPT	1 3/8	4 7/8	3 3/32	4 3/32	4 1/8
	182TC, 184TC	6 15/16	3C1F534-182	3C1F51-182	182TC	2 3/4	5 1/2	3 3/4	4 1/2	4CF	1 1/2" NPT	1 15/32	4 1/8	4 13/32	5 13/32	3 3/4
4CF	213TC, 215TC	7 11/16	3C1F534-213	3C1F51-213	213TC	3 1/2	5 1/2	4 1/4	5 1/4	5CF	1 1/2" NPT	2 3/8	5	5 11/16	6 15/16	4 3/4
	182TC, 184TC	6 7/8	5C1F534-182	5C1F51-182	215TC	3 1/2	7	4 1/4	5 1/4	6CF	2" NPT	2 5/8	4 3/4	6 1/8	7 3/8	4 3/4
	254TC, 256TC	7 5/8	5C1F534-213	5C1F51-213	254TC	4 1/4	8 1/4	5	6 1/4	5CF	1 1/2" NPT	2 3/8	5	5 11/16	6 15/16	4 3/4
5CF	213TC, 215TC	7 5/8	5C1F534-213	5C1F51-213	256TC	4 1/4	10	5	6 1/4	6CF	2" NPT	2 5/8	4 3/4	6 1/8	7 3/8	4 3/4
	254TC, 256TC	8 5/16	5C1F534-254	5C1F51-254	284TC	4 3/4	9 1/2	5 1/2	7	5CF	1 1/2" NPT	2 3/8	5	5 11/16	6 15/16	4 3/4
	284TC, 286TC	9 1/4	5C1F534-284	5C1F51-284	286TC	4 3/4	11	5 1/2	7	6CF	2" NPT	2 5/8	4 3/4	6 1/8	7 3/8	4 3/4
6CF	324TC, 326TC	9 3/4	5C1F534-324	5C1F51-324	324TC	5 1/4	10 1/2	6 1/4	8	5CF	1 1/2" NPT	2 3/8	5	5 11/16	6 15/16	4 3/4
					326TC	5 1/4	12	6 1/4	8	6CF	2" NPT	2 5/8	4 3/4	6 1/8	7 3/8	4 3/4

Dimensions for Adapter Mounting C2B & 4300 Pumps to NEMA C Frame Motors

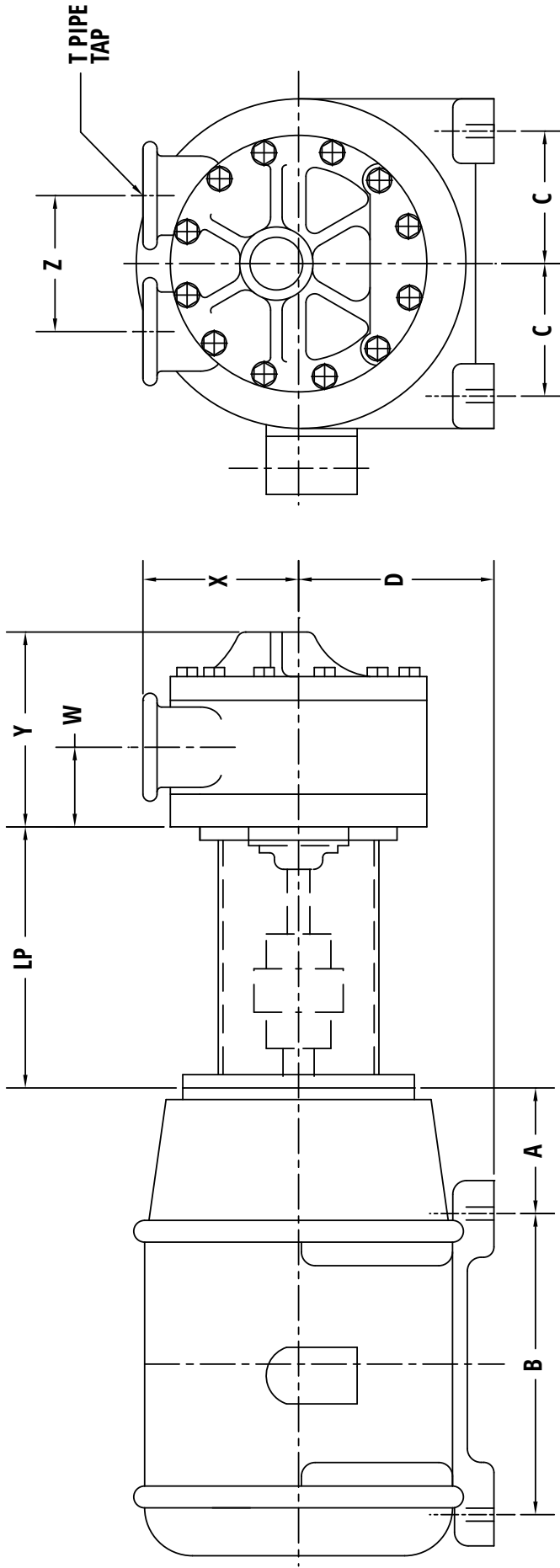

Pump Model	Motor Frame Size	LP	Adapter	Adapter Kit	Motor Frame	A	B	C	D	T	W	X	Y	Y DIM WITH RELIEF VALVE	Z
2C2B 4312	56C	7 15/16	2C1B51-56	2C1B534-56	56C	2 3/4	3	2 7/16	3 1/2	1" NPT	1	3 11/16	2 1/2	3 19/32	3 1/8
	143TC, 145TC	7 15/16	2C1B51-56	2C1B534-143	143TC	2 1/4	4	2 3/4	3 1/2	1 1/4" NPT	1 3/8	4 7/8	3 3/32	4 3/32	4 1/8
	182TC, 184TC	8 9/16	2C1B51-182	2C1B534-182	145TC	2 1/4	5	2 3/4	3 1/2	1 1/2" NPT	1 15/32	4 1/8	4 13/32	5 13/32	3 3/4
3C2B 4313	56C	8 5/16	3C2B51-56	3C2B534-56	182TC	2 3/4	4 1/2	3 3/4	4 1/2	1 1/2" NPT	1 3/8	4 7/8	3 3/32	4 3/32	4 1/8
	143TC, 145TC	8 5/16	3C2B51-56	3C2B534-143	184TC	2 3/4	5 1/2	3 3/4	4 1/2	1 1/2" NPT	1 15/32	4 1/8	4 13/32	5 13/32	3 3/4
	182TC, 184TC	8 15/16	3C2B51-182	3C2B534-182	213TC	3 1/2	5 1/2	4 1/4	5 1/4	1 1/2" NPT	2 3/8	5	5 11/16	6 15/16	4 3/4
4C2B 4314	213TC, 215TC	9 11/16	3C2B51-213	3C2B534-213	215TC	3 1/2	7	4 1/4	5 1/4	2" NPT	2 5/8	4 3/4	6 1/8	7 3/8	3 3/4
	182TC, 184TC	9 3/4	5C2B51-182	5C2B534-182	254TC	4 1/4	8 1/4	5	6 1/4	1 1/2" NPT	2 3/8	5	5 11/16	6 15/16	4 3/4
	213TC, 215TC	10 1/2	5C2B51-213	5C2B534-213	256TC	4 1/4	10	5	6 1/4	1 1/2" NPT	2 3/8	5	5 11/16	6 15/16	4 3/4
5C2B 4315	254TC, 256TC	11 3/16	5C2B51-254	5C2B534-254	284TC	4 3/4	9 1/2	5 1/2	7	2" NPT	2 5/8	4 3/4	6 1/8	7 3/8	3 3/4
	284TC, 286TC	11 15/16	5C2B51-284	5C2B534-284	286TC	4 3/4	11	5 1/2	7	2" NPT	2 5/8	4 3/4	6 1/8	7 3/8	3 3/4
	324TC, 326TC	12 11/16	5C2B51-324	5C2B534-324	324TC	5 1/4	10 1/2	6 1/4	8	2" NPT	2 5/8	4 3/4	6 1/8	7 3/8	3 3/4
6C2B 4316	324TC, 326TC	12 11/16	5C2B51-324	5C2B534-324	326TC	5 1/4	12	6 1/4	8	2" NPT	2 5/8	4 3/4	6 1/8	7 3/8	3 3/4

Dimensions for Adapter Mounting CK2B Pumps to NEMA C Frame Motors

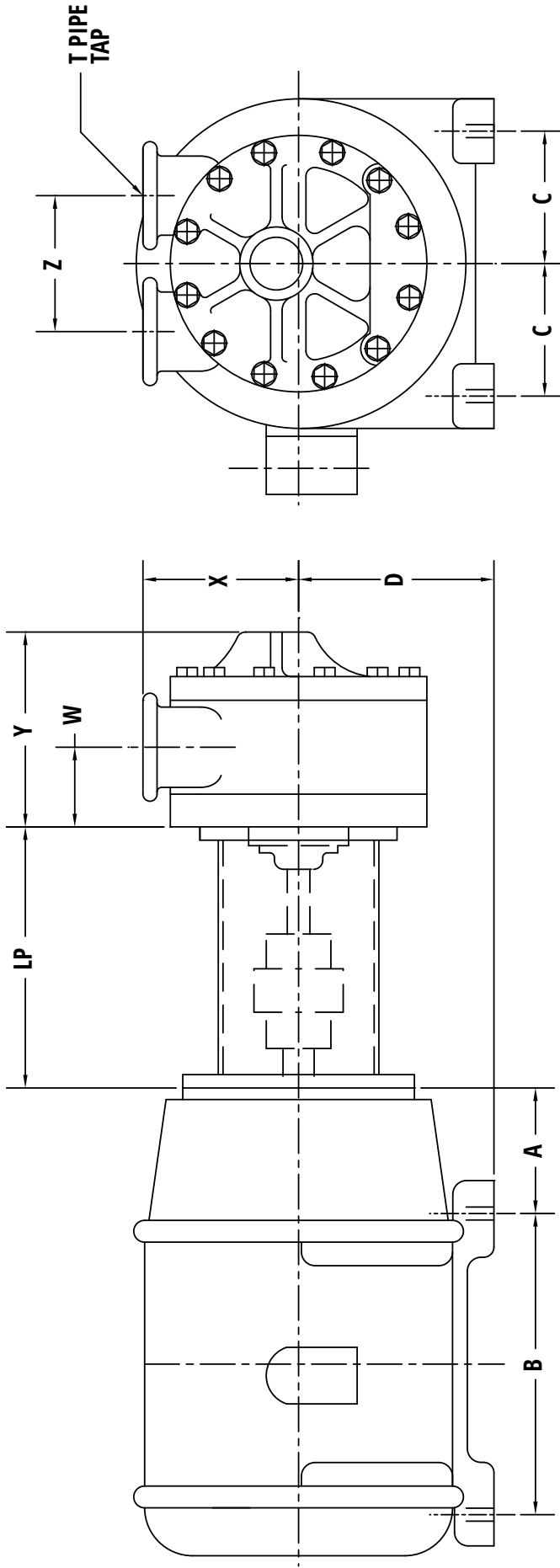

Pump Model	T	W	X	Y	Y DIM WITH RELIEF VALVE	Z
4CK1B	1" NPT	1 3/16	3 3/4	3 19/32	4 19/32	3 3/4
6CK1B	2" NPT	1 3/4	4 3/4	5 9/16	6 13/16	4 3/4

Motor Frame	A	B	C	D
56C	2 3/4	3	2 7/16	3 1/2
143TC	2 1/4	4	2 3/4	3 1/2
145TC	2 1/4	5	2 3/4	3 1/2
182TC	2 3/4	4 1/2	3 3/4	4 1/2
184TC	2 3/4	5 1/2	3 3/4	4 1/2
213TC	3 1/2	5 1/2	4 1/4	5 1/4
215TC	3 1/2	7	4 1/4	5 1/4
254TC	4 1/4	8 1/4	5	6 1/4
256TC	4 1/4	10	5	6 1/4
284TC	4 3/4	9 1/2	5 1/2	7
286TC	4 3/4	11	5 1/2	7
324TC	5 1/4	10 1/2	6 1/4	8
326TC	5 1/4	12	6 1/4	8

Pump Model	Motor Frame Size	LP	Adapter	Adapter Kit
4CK1B	56C	8 5/8	3CK1B51-56	3CK1B534-56
	143TC, 145TC	8 5/8	3CK1B51-56	3CK1B534-56
	182TC, 184TC	9 1/8	3CK1B51-182	3CK1B534-182
	213TC, 215TC	10 1/4	3CK1B51-213	3CK1B534-213
	182TC, 184TC	10 5/16	5CK1B51-182	5CK1B534-182
6CK1B	213TC, 215TC	11 1/16	5CK1B51-213	5CK1B534-213
	254TC, 256TC	11 7/8	5CK1B51-254	5CK1B534-254
	284TC, 286TC	12 7/8	5CK1B51-284	5CK1B534-284
	324TC, 326TC	13 3/4	5CK1B51-324	5CK1B534-324

Dimensions for C Series Mounting Feet (2C81, 3C81, 3CK81 & 5C81)

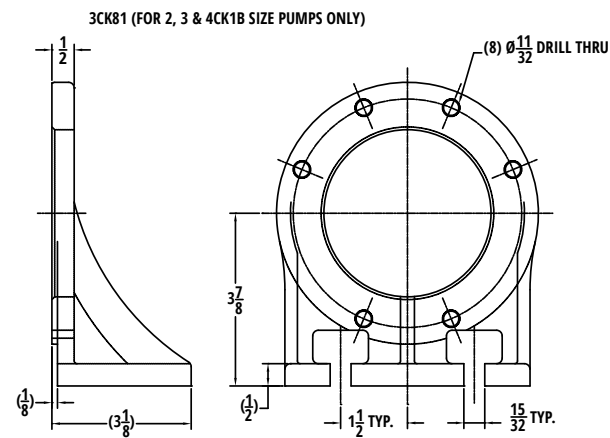
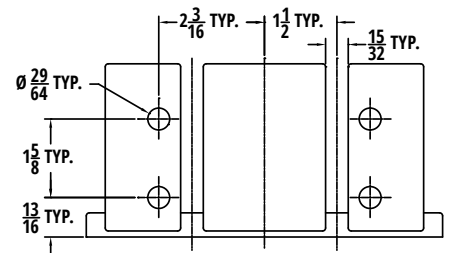
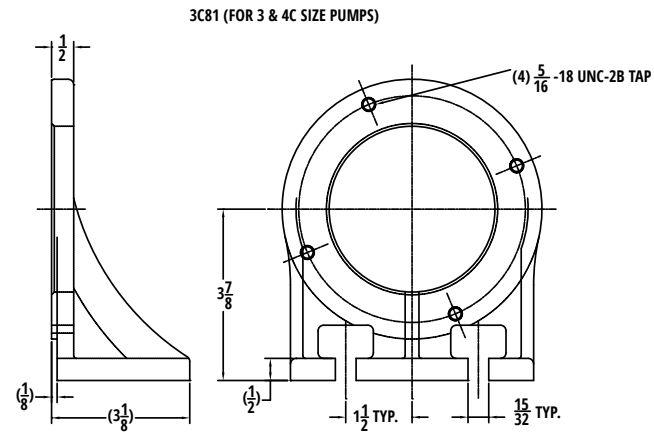
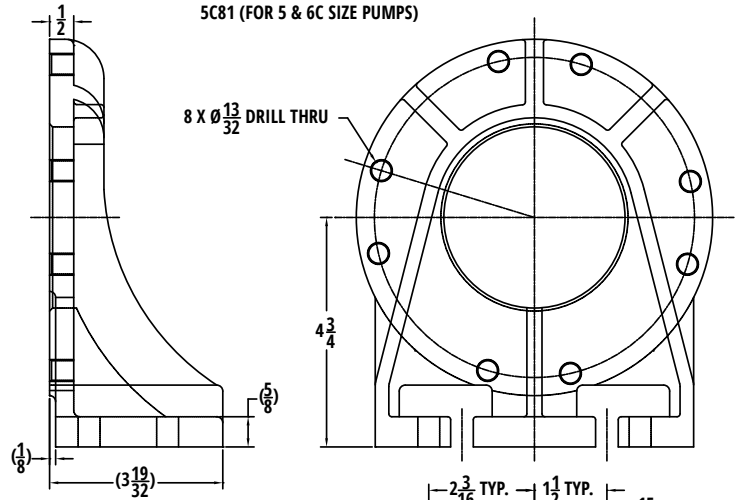
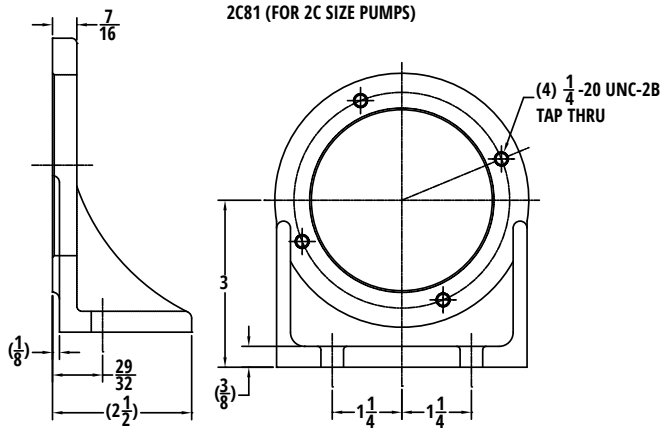

4310 Pump Mounting Dimensions

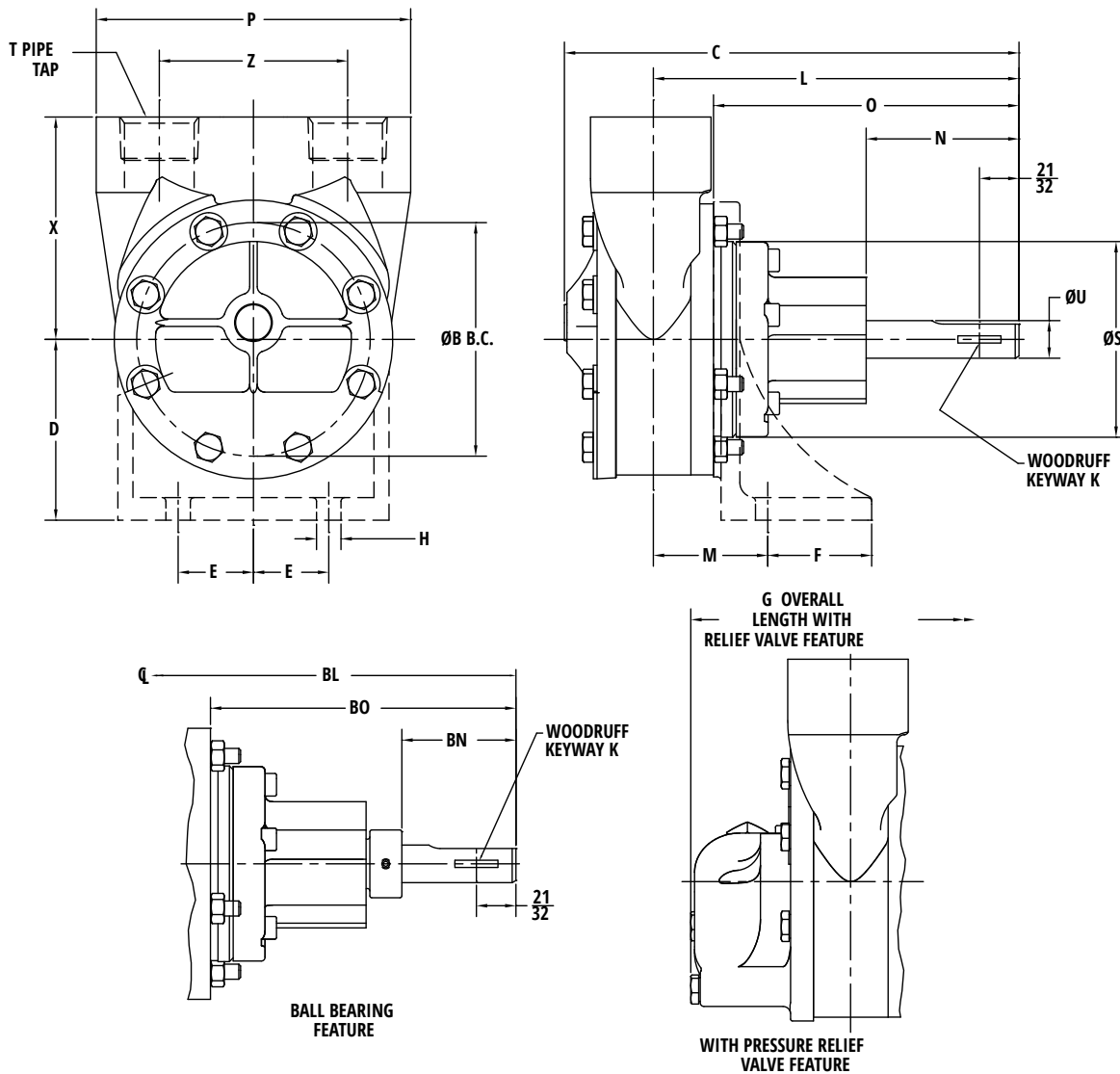

Model	B	C	G	D	E	F	H	K	L	M	N	O
4312	3 7/8	7 9/16	8 21/32	3	1 1/4	1 19/32	13/32	#406	6 1/16	1 29/32	2 17/32	5 1/16
4313	5 1/8	8 17/32	9 17/32	3 7/8	1 1/2	SLOT	15/32	#606	6 13/16	SLOT	2 1/2	5 7/16
4314	5 1/8	9 27/32	10 7/32	3 7/8	1 1/2	SLOT	15/32	#606	6 29/32	SLOT	2 1/2	5 7/16
4315	6 5/8	11 15/16	13 1/8	4 3/4	1 1/2	SLOT	15/32	#808	8 5/8	SLOT	3 13/32	6 1/4
4316	6 5/8	12 3/8	13 5/8	4 3/4	1 1/2	SLOT	15/32	#808	8 7/8	SLOT	3 13/32	6 1/4

Model	P	S	T	U	X	Z	BL	BN	BO
4312	5 7/32	3 1/4	1" NPT	5/8	3 11/16	3 1/8	6 1/16	1 27/32	5 1/16
4313	6 5/8	3 3/4	1 1/4" NPT	3/4	4 7/8	4 1/8	6 13/16	1 25/32	5 7/16
4314	6 1/2	3 3/4	1 1/2" NPT	3/4	4 1/8	3 3/4	6 29/32	1 25/32	5 7/16
4315	7 1/2	3 3/4	1 1/2" NPT	1	5	4 3/4	8 5/8	2 9/16	6 1/4
4316	8 1/8	3 3/4	2" NPT	1	4 3/4	4 3/4	8 7/8	2 9/16	6 1/4

4300 Pump Model Number System

Position #	Pump		Sub-Group	Size	Pump Option	Rotation for Valved Models		Modifications					SAE Port Option	
	1	2	3	4	5	6	7	8	9	10	11	12	13	14

Position #	Description	Codes
1 & 2	Pump	-43
3	Sub-Group	-1 = Standard Design
4	Size	-2, -3, -4, -5, or -6
5	Pump Option	-V = Valve, -N = Outboard Ball Bearing, or -U = Cover Rotated 180°
6 & 7	Rotation for Valved Models	-C = Clockwise Rotation or -CC = Counterclockwise Rotation
8, 9, 10, 11, & 12	Modifications	-5 = Neoprene Seal, -7 = Viton Seal, -78910 = Abrasion Resistant Seal -8 = EPR Seal, -N = No Flat/Keyway in Shaft
13, 14, & 15	SAE Port Option	-SAE (NPT Standard)

4300 Series Port Sizes

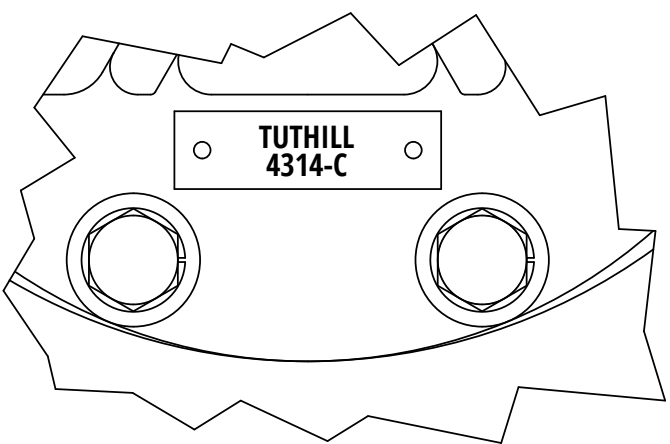
Port		Pump Size					Model Number is Stamped on a Metal Tag on the Cover
Style	Size	2	3	4	5	6	
NPT	1"	STD.	-	-	-	-	
	1 1/4"	-	STD.	-	-	-	
	1 1/2"	-	-	STD.	STD.	-	
	2"	-	-	-	-	STD.	
SAE	16	OPT.	-	-	-	-	
	20	-	OPT.	OPT.	-	-	
	24	-	-	-	OPT.	-	
	32	-	-	-	-	OPT.	

4300 Pump Temperature Limits

Material	Minimum	Maximum
Carbon Bushing	-100 °F	500 °F
Viton	-10 °F	375 °F
Neoprene	-40 °F	200 °F
Ethylene Propylene (EPR)	-40 °F	300 °F

Note: A pump's performance is dependent on more than just the temperature ranges of the component materials.

4300 Pump Materials of Construction

Part Name	Material	Standard	Comments	Availability
Housing	Cast Iron	ASTM A48 – 96a	Classes 30, 35, or 40	Std.
Bracket	Cast Iron	ASTM A48 – 96a	Classes 30, 35, or 40	Std.
Bracket Bushing	Carbon	Carbon Graphite Resin		Std.
	Ceramic	Alumina Ceramic, Diamonite	Std. on 4230 & 4330 Models	Opt.
Cover	Cast Iron	ASTM A48 – 96a	Classes 30, 35, or 40	Std.
Rotor	Steel	C1137 or C1141	Steel Forging	Std.
Idler	Steel	C1117		Std.
Idler Pin	Steel	C1117	Heat Treated	Std.
Idler Bushing	Carbon	Carbon Graphite Resin		Std.
Seal Gland	Cast Iron	ASTM A48 – 96a	Classes 30, 35, or 40	Std.
	DU Bushing		Only on 4310 models	
O-Ring & Seal	Viton			STD
	Neoprene			Opt.
	EPR			Opt.

4000/C Cross Reference List

4310 Pumps	C2B Pump	4310 Series Additional Features
4312	2C2B	- Carbon Bracket Bushing vs. Bronze
		- Steel Idler Gear vs. Powdered Metal
		- Carbon Idler Bushing vs. None
4313	3C2B	- Carbon Bracket Bushing vs. Bronze
		- Steel Idler Gear vs. Powdered Metal
		- Carbon Idler Bushing vs. Bronze
4314	4C2B	Same as Above
4315	5C2B	Same as Above
4316	6C2B	Same as Above
Options	-V, -5, -8, and Mounting Feet (2C81, 3C81 & 5C81) are available on both pumps.	

Note: The Tuthill reversing feature is not available on 4000 pumps. 4310 pumps have the same assembled dimensions as their C2B pump counterparts.

CC09 Pump/NEMA Motor Mounting Dimensions

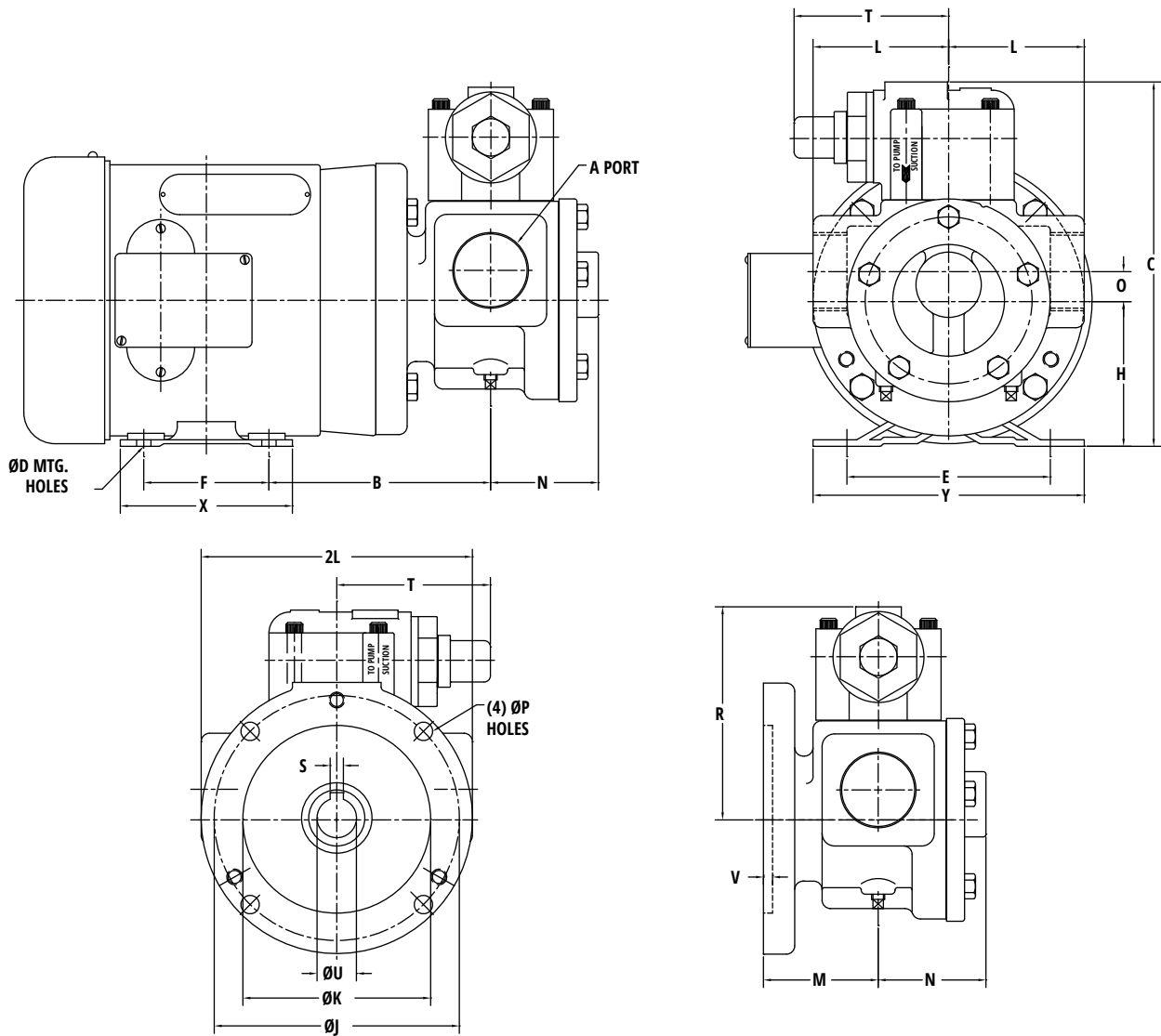

Motor Frame Size	A	B	C	D	E	F	H	J	K	L	M	N	O
56C		5 25/64	8 5/16	11/32	4 7/8	3	3 1/2	5 7/8	4 1/2	2 1/2	2 53/64	1 31/64	17/32
143TC	1" NPT	5 5/64	8 5/16	11/32	5 1/2	4	3 1/2	5 7/8	4 1/2	2 1/2	2 53/64	1 31/64	17/32
145TC		5 5/64	8 5/16	11/32	5 1/2	5	3 1/2	5 7/8	4 1/2	2 1/2	2 53/64	1 31/64	17/32

Motor Frame Size	P	R	S	T	U	V	X	Y
56C	15/32	4 13/16	3/16	3 23/32	5/8	15/64	3 3/4	6 3/16
143TC	15/32	4 13/16	3/16	3 23/32	7/8	15/64	5	6 7/8
145TC	15/32	4 13/16	3/16	3 23/32	7/8	15/64	5	6 7/8

CC015, 020 & 030 Pump/NEMA Motor Mounting Dimensions

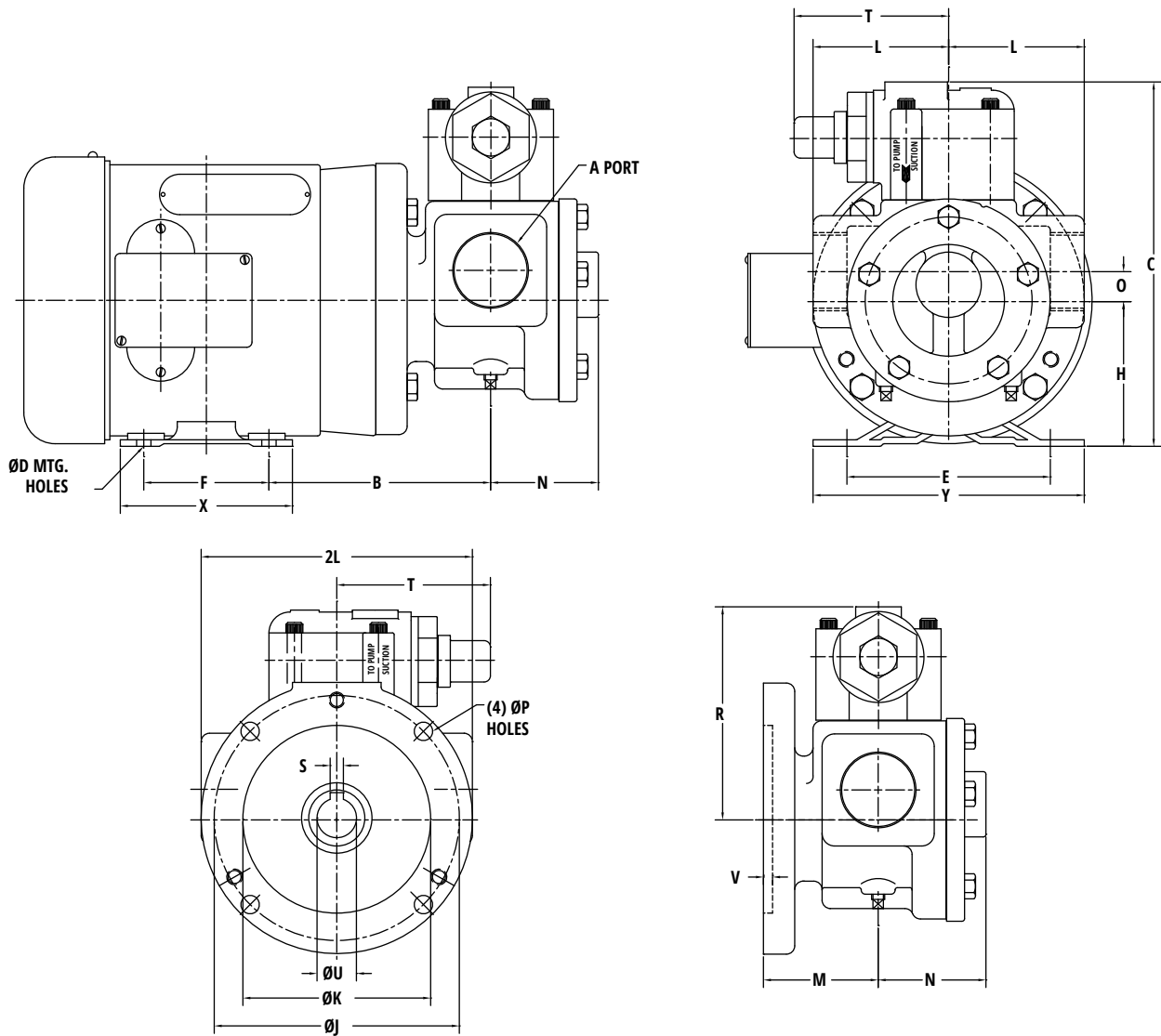

Motor Frame Size	A	B	C	D	E	F	H	J	K	L	M	N
56C	1 1/2" NPT	5 23/64	8 49/64	11/32	4 7/8	3	3 1/2	5 7/8	4 1/2	3 1/4	2 47/64	2 23/32
143TC	1 1/2" NPT	5	8 49/64	11/32	5 1/2	4	3 1/2	5 7/8	4 1/2	3 1/4	2 47/64	2 23/32
145TC	1 1/2" NPT	5	8 49/64	11/32	5 1/2	5	3 1/2	5 7/8	4 1/2	3 1/4	2 47/64	2 23/32

Motor Frame Size	O	P	R	S	T	U	V	X	Y
56C	5/8	15/32	4 3/8	3/16	3 45/64	5/8	15/64	3 3/4	6 3/16
143TC	5/8	15/32	5 17/64	3/16	3 45/64	7/8	15/64	5	6 7/8
145TC	5/8	15/32	5 17/64	3/16	3 45/64	7/8	15/64	6	6 7/8

CC Pump Model Number System

	Pump Series		Material of Construction	Frame Size	Pump Size			Porting	Seal Elastomer	Rotation		Valve Type	Special Modification
Position #	1	2	3	4	5	6	7	8	9	10	11	12	13

Position #	Description	Codes
1 & 2	Pump Series	-CC
3	Material of Construction	-I = Iron
4	Frame Size	-1 = 5/8" (56C), -2 = 7/8" (143/145TC)
5, 6, & 7	Pump Size	-009, -015, -020, or -030
8	Porting	-1 = NPT
9	Seal Elastomer	-3 = Buna, -5 = Neoprene, -7 = Viton, -8 = EPR, or -9 = Other (All Type 2)
10 & 11	Rotation	-C = Clockwise or -CC = Counterclockwise
12	Valve Type	-V = Relief Valve
13	Special Modification	Assigned by Tuthill Pump Group engineering as required

CC Pump Temperature Limits

Material	Minimum	Maximum
Carbon Bushing	-100 °F	500 °F
Viton	-10 °F	375 °F

Notes: A pump's performance is dependent on more than just the temperature ranges of the component materials.

CC Pump Materials of Construction

Part Name	Material	Availability	Standard	Comments
Housing	Cast Iron	Std.	ASTM A48 – 96a	Classes 30, 35, or 40
Cover	Cast Iron	Std.	ASTM A48 – 96a	Classes 30, 35, or 40
Rotor	Ductile Iron	Std.	ASTM A536	Ductile Iron Grade 80-55-06
Idler	Ductile Iron	Std.	ASTM A536	Ductile Iron Grade 80-55-06
Idler Pin	Steel	Std.	C1117	Heat Treated
Idler Bushing	Carbon	Std.	Carbon Graphite Resin	
Relief Valve Body	Cast Iron	Std.	ASTM A48 – 96a	Classes 30, 35, or 40
Relief Valve Block-Off Plate	Steel	Std.	ASTM A36	
Gaskets	Standard	Std.	Oriented Polyester	
	Standard	Std.	Garlock	Used for Relief Valve Pumps Only
Seal	Viton	Std.		

CC Pump NPSH Data

NPSH Required for Tuthill "CC" Series pumps 0-750 SSU

Pump Series		300	600	900	1200	1500	1800
CC009	FT.	1.4	1.9	3.1	4.5	6.4	9.1
CC015	FT.	1.5	2.1	3.3	5.0	7.0	9.8
CC020	FT.	1.6	2.3	3.6	5.5	7.7	10.4
CC030	FT.	1.7	2.6	4.1	6.6	9.1	11.8

Notes: For liquid viscosity up to 750 SSU NPSHA (Net Positive Suction Head Available) must be greater than the NPSHR (Net Positive Suction Head Required) value provided in the table. Values above are for feet of liquid with a Specific Gravity of (1.0).

Viscosity Correction Factor

1000 SSU	1500 SSU	2000 SSU	2500 SSU
1.15 Correction Factor	1.20 Correction Factor	1.25 Correction Factor	1.3 Correction Factor